



SOLUTIONS

FOODSERVICE

2026 PRICE LIST



Lincat *imc* frifri Britannia

4 Global Brands

UK
CA CE



2
YEAR

UK parts
and labour
warranty

Export
parts
warranty

on all products*

*excluding mobile hand wash stations
supplied with 1 year warranty

Your complete foodservice solution from one supplier

Lincat

- Prime Cooking Equipment
- Water Boilers
- Holding and Servery



Page L1

frifri

- Fryers
- Pasta Cookers
- Chip Scuttles



Page F1

imc
fresh thinking

- Bar Systems
- Vegetable Preparation
- Waste Management
- Cleaning and Rinsing



Page i1

Britannia

- Ventilation
- Recirculation



Page B1

**The Exclusive
Distributor**



for **Lincat Spare Parts** for the UK and ROI.



PartstOWNUK

Telephone 01543 577 778 Email lincatspares@partstown.co.uk

UK Tel: 01522 875500 Export Tel: +44 1522 503250 UK e-mail: sales@lincat.co.uk Export e-mail: export@lincat.co.uk

Lincat Limited, Whisby Road, Lincoln. LN6 3QZ. United Kingdom.

Group member of **MIDDLEBY**

All prices are exclusive of VAT.

UK - Goods are normally delivered free of charge to either the dealers' address or direct within 3 working days. If overnight and/or premium services are required charges will apply.

Export - Goods are priced ex works, export crates POA.

Any units which are built to order or include factory fit options are non-returnable.

Lincat

lincat.co.uk

2026

COMING
SOON!

AIR⁰

by **Lincat**

Zero Oil. Full Crunch!

The Next Generation of
Commercial Air Frying

Key Features & Benefits:

True Commercial Power, Accessible Price

Finally - a serious air fryer
made for busy kitchens, without
the premium price tag.

Plug & Play

Standard 3kW plug -
no installation faff.

Oil-Free = Healthier Profits

Serve healthier food,
cut oil costs to zero.

Compact & Stackable

Perfect for space-starved
kitchens.

Simple & Intuitive

7" touchscreen with icons -
quick to learn, easy to use.

Cleaner Air, Happier Team

Catalytic converter
removes airborne fats.

Quick to Clean, Built to Last

Removable GN 2/3 cavity
for fast deep cleaning.

Ventless Operation

No extraction
system needed.



Fast & Consistent Cook Times

- **Fries 500g:** 4:30 | **800g:** 8:30 (shake halfway)
- **Chicken Goujons 400g:** 4:30
- **Nuggets (12 pcs):** 5:30
- **Fish Fingers (16 pcs):** 5:30
- **Hash Browns (8 pcs):** 6:30

Try it. Taste it. Believe it.

call: **01522 875 500**
email: sales@lincat.co.uk

REGISTER
your interest



CIBO+

TURBOCHEF



SETTING THE BENCHMARK IN HIGH SPEED VENTLESS COOKING

This next-generation CIBO+ carries the strength of the TurboChef brand while keeping the same outstanding performance, reliability, and versatility chefs already depend on.

The first change you'll notice is the bigger 7" touchscreen, making operation faster, smoother, and more intuitive. The oven also features updated TurboChef branding and is now available exclusively in sleek black under code TCIBOPLUS/B.

Just as important, the core features remain unchanged and it is still proudly manufactured by Lincat, backed by a 2-year warranty (parts & labour).



Programmes	80 menu items
Temperature	Five temperatures groups
Cooking area size	340mm x 340mm
Heat Methods	Microwave, ContactBase, TurboAir
Base Heat	Direct cook on the toughened neo ceram ContactBase - no soggy, sweaty bottom
Colouration	ContactBase and TurboAir for even colouration
Touch Screen	7 inch (800 x 480 pixels)
Cooldown	Cooldown+, no ice required



WHAT COULD YOU DELIVER?



Bacon Roll

Cooks in 45 secs.

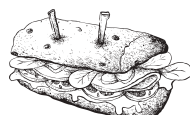

Paninis

Cooks in 45 secs.



Ribs & Fries

Cooks in 1 min. 20 secs.



Vegan Pizza

Cooks in 1 min. 35 secs.

2
YEAR

UK parts
and labour
warranty

Turbochef CiBO+ High Speed Oven

- Cooks in seconds, broadening your menu options to include denser items such as pies and lasagne
- Compact yet able to accommodate a 12" pizza
- Ventless and adaptable for use in virtually any setting
- 3kW plug-and-play limit, with power seamlessly transitioning between the three heat sources
- Cutting-edge, patented tri-heat technology, ensuring unparalleled quality results for every order
- User-friendly QPad touch screen, addressing challenges such as varying culinary skills and language barriers
- Connected model, lets you connect, monitor, and manage ovens across multiple locations via Open Kitchen® by Powerhouse Dynamics

ARRIVING in 2026

 Connected model with **Open Kitchen®** by Powerhouse Dynamics.



Turbochef CiBO+ High Speed Oven							
MODEL	PRICE £	PRICE €	DESCRIPTION	H	W	D	POWER WT
TCIBOPLUS/B	£7449	€8568	Black Glass	640	395	728	3kW 65
Internal usable dimensions				195	340	340	

MODEL	PRICE £	PRICE €	DESCRIPTION
A LT02	£70	€81	Paddle with handguard and sides
C CIBO/TT	£79.70	€92.15	Non-stick Teflon Tray
C TFS05	£13.50	€15.55	Non-stick Teflon Sheets
A NSBT23	£131	€151	Non-stick Baking Tray
A CIBO/ET	£23	€27	Multi-tray
A SH136	£22	€26	Wire rack*
A SK05	£1375	€1582	Moveable Stacking Stand, with front lock castors
A LTH01	£70	€81	Magnetic Paddle Holder
A CIBOPLUS/USB	£31	€36	USB Drive
C RC05	£110.40	€132.45	Oven Cavity Back Plate
A RCP1	£38	€46	RC05 Fitting Kit
A PP12	£844	€1013	CiBO+ Panini Press
C OC02	£29.35	€33.80	Oven Cleaner Kit

* For programmes with microwave

Included with the oven:



Paddle with handguard and sides **LT02**

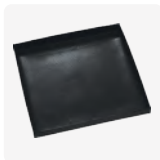

Teflon Tray **CIBO/TT**



Teflon sheet **TFS05**



USB Stick **CIBOPLUS/USB**

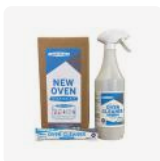

Oven Cleaner Kit **OC02**

Optional Accessories



Magnetic Paddle Hanger **LTH01**



Non-stick Baking Tray **NSBT23**



Moveable Stacking Stand, with front lock castors **SK05**



CiBO+ Oven Cavity Back Plate **RC05**

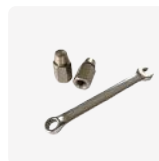

Fitting Kit for RC05 **RCP1**

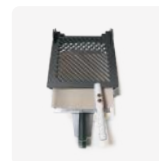

CiBO+ Panini Press **PP12**



Multi-tray **CIBO/ET**



Wire rack **SH136**

New Products

OPUS

IGNITE



High Efficiency Electric Chargrills

OE8415, OE8416 and OE8417

Experience the next generation of British culinary innovation, designed to meet the demands of modern kitchens. Opus Ignite offers authentic chargrilling without gas or solid fuels, supports the move toward fully electric kitchens, and helps operators reduce energy use and environmental impact – all without compromising on taste.

Find out more on [page L16](#)

Invoq | miniCombi



miniCombi

Just like its bigger Invoq siblings, miniCombi is engineered for consistency, efficiency, and ease of use – from fast-paced lunch service to overnight slow cooking. It's also a natural upgrade from our previous CombiSlim model, bringing new intelligence and performance into the same slim footprint.

Invoq | Essence



Essence

The Invoq Essence gives you all the essential functionality of previous Invoq models without the frills. Powered by the latest technology. Designed to evolve with your needs, it can be upgraded at any time with a range of tailored packages.



Lincat

2026 PRICE LIST



SPECIALISING IN

- PRIME COOKING EQUIPMENT
- WATER BOILERS
- HOLDING & SERVERY

Contents



Opus 800

Powerful cooking all day long

Heavy Duty Prime
Cooking Equipment

Ideally suited for:

Busy restaurants, chain restaurants and high-volume kitchens, that barely stop from breakfast right on through to closing time.

Why choose Opus 800?

- 800mm deep
- Enhanced performance, energy efficiency and serviceability

- Strong and durable
- Increased capacity
- Gas and electric versions available
- Easy to clean

Find out more on page

L5



CONVECTOR

Putting you in control for perfect results every time

Convection Ovens

Ideally suited for:

Busy restaurants, bakeries and high-volume kitchens.

Why choose Convector?

- Uniform results, every time, even when full
- Roast, braise, bake and reheat
- Strong and durable

- Two-speed bi-directional fan
- Oven cavity optimised for airflow
- Manual+ and Touch models available
- Intuitive easy to use controls

Find out more on page

L23



Lincat CombiSlim

Lincat CombiSlim provides maximum flexibility in minimum space

Combi Ovens

Ideally suited for:

Lincat CombiSlim ovens are small but effective, providing the same features as a large combi oven to give you maximum flexibility when space is at a premium.

Why Choose Lincat CombiSlim?

- 513mm wide footprint
- Accommodates 6 or 10 1/1GN trays
- Consistent results regardless of the operator

- Steam injection
- SmartChef® pre-set recipes
- Easy to use SmartTouch®, intuitive touch control display
- CombiSmart® 10 steps, humidity control

Find out more on page

L29



Lincat Invoq

Introducing an intuitive oven platform for baking, cooking and steaming that's as simple as it looks.

Invoq Combi, Hybrid and Bake

Ideally suited for:

Lincat Invoq is a single solution tailored to meet the needs of different market segments. From restaurants to institutional kitchens and supermarkets. It has been designed from the point of view of chefs, kitchen designers and consultants.

Why Choose Lincat Invoq?

- Invoq Combi and Hybrid with an extra tray in 6 grid ovens, delivers 17% more capacity
- Invoq Bake with an extra tray, delivers 20% more capacity
- Less energy usage
- Automatic, intelligent cooking regardless of operator or skill level

- ClimateControl, perfectly controlled for optimum quality
- Innovative steam generation technologies
- Fine tune for humidity levels
- CareCycle automatic cleaning system
- Open Kitchen compatible
- SmartPhone simple to use

Find out more on page

L35



blu°

KEEPING IT COOL

Refrigerated storage and easy access of food at point of cooking

Fridges, Freezers & Blast Chillers

Ideally suited for:

Busy restaurants, chain restaurants and high-volume kitchens.

Why choose blu°?

- Holds food at the optimum temperature

- Increased efficiency, storing food at point of cooking

Find out more on page

L63



PHOENIX

Powerful performance at a low price point

Medium Duty
Cooking Equipment

Ideally suited for:

Medium sized pubs and restaurants, schools and care homes.

Why choose Phoenix?

- Ideal for cost conscious who don't want to sacrifice quality, power and performance
- Will handle day to day demands of the busiest of kitchens

- Robust and durable
- Gas and electric versions available
- Easy to clean

Find out more on page

L65



SILVERLINK 600

Configure your cooking with modular flexibility

Modular Cooking Equipment

Ideally suited for:

Care homes, cafe bars and small to medium pubs and restaurants, serving on a shift basis (lunch and dinner).

Why choose Silverlink 600?

- 600mm deep
- Modular kitchen equipment that will allow you to build a custom appearance for your kitchen
- Free standing and counter top units can be sited on a range of ovens, pedestals and stands
- Gas and electric versions available
- Easy to clean

Find out more on page

L69



LYNX400

Reliable and cost-effective, plug in and play cooking

Compact Counter Top Cooking Equipment

Ideally suited for:

kitchens and portable setups.

Why choose Lynx 400?

- Compact, portable, and electric, ready to use with a UK 3-pin socket right out of the box
- Includes fryers, grills, griddles, pasta cookers, and more
- Designed for effortless operation and efficiency in any setting
- Built for durability and performance
- Ideal for budget-conscious operations

Find out more on page

L81



Lincat Specialist

'Built for purpose' cooking equipment

Convection Ovens, Pizza Ovens, Food Warming Drawers, Induction Hobs, Fume Filtration, Ventilation Systems

Ideally suited for:

Specialist applications.

Why choose Lincat?

- Series is 'built for purpose' and supports menu offering
- Wide range of specialist products
- Guaranteed quality

Find out more on page

L89



PANTHER

Ensuring that perfect dishes stay perfect

Static and Mobile Hot Cupboards

Ideally suited for:

Care homes, restaurants and schools.

Why choose Panther?

- 670 and 800 series are available in various lengths
- Robust and flexible hot cupboards can transport food as well as being used as a servery or kitchen pass
- Fully configurable to meet your needs

Find out more on page

L97



Quality hot water on tap 24/7

Auto and Manual Fill water boilers

Ideally suited for:

Offices and staff rooms, cafe bars and anywhere else where you need high volumes of boiling water.

Why choose Filterflow?

- High quality boiling water on tap 24/7
- Ensures that tea breaks no longer have to include waiting around
- Built in filtration system with a high volume, easy change FilterFlow cartridge
- High output from narrow footprint
- Easy to use and cheap to run
- Enhanced diagnostics
- Connected to the mains and water supply

Find out more on page

L105



SEAL

Showcase your food and increase sales

Heated, Refrigerated and Ambient Merchandisers

Ideally suited for:

School and college canteens, hotels and cafés.

Why choose Seal?

- Ambient, refrigerated and heated range of merchandisers and displays
- Option of back service or self service operation
- Offer a reliable method for keeping food in the optimum condition before service
- The sleek and elegant designs show off your food at its best to tempt customers.

Find out more on page

L111



OPUS 800



The Opus 800 series is built for power and performance.

High volume, high quality cooking is simple with the powerful Opus 800 series of 800mm deep oven ranges, boiling tops, fryers, grills, griddles, and bratt pans.

Designed to heat quickly, the Opus 800 series is made for non-stop establishments where kitchens are a constant hive of activity. The equipment can go on cooking delicious dishes all day long, from breakfast through to midnight.

The strong, durable series comes with both electric and gas models, and can be configured in a variety of ways, such as with pedestals and stands. Create a seamless, stylish look that's perfect for front of house and open kitchens.

Ideally suited for...

The heavy-duty Opus 800 series is perfect for the most demanding of kitchens. If your kitchen barely stops, then Opus 800 is the series for you.

The power of the Opus 800 series means it can deliver vast quantities of quality food. It won't let you down.



Large chain pubs and restaurants

Is your kitchen constantly under pressure to deliver delicious dishes at high volumes? If so, you'll find what you're looking for in the Opus 800 series.



Large hospitals

If you need to cook a vast quantity of meals for patients, the Opus 800 series has the capacity to deliver time after time.



Schools

Hundreds of children waiting for their lunchtime meal is no reason to stress when you've got the heavy-duty Opus 800 series ready to go in your kitchen.



Care homes

The Opus 800 series is designed for high output - perfect for when you've got to cook lots of meals at set times for residents.

Benefits at a glance

- 800mm deep
- Heavy duty
- For high output establishments cooking all day long
- Enhanced performance
- Strong and durable
- Increased capacity
- Gas and electric models
- Easy to clean



Most Opus 800 products are SUPPLIED WITH CASTORS AS STANDARD

Please contact us if you require products to be supplied with legs



OPUS 800

All gas power ratings are nominal values.

Gas Oven Ranges

Gas open top hob

- 7.5kW dual concentric burners for focused heat distribution from a fast boil to a low simmer
- Individual heavy-duty single cast iron supports, built to withstand the rigours of the busiest kitchen
- Flame failure protection
- Low flue to allow use of the complete hob top
- Drip tray

Inclusive Accessories

- 2 chrome plated shelves

Oven

- 6.8kW (OG8001) and 10kW (OG8002) ovens
- Precise thermostatic control from 120°C to 260°C
- Large capacity oven, 2 x GN1/1 (OG8001) and 4 x GN1/1 (OG8002)
- 2 shelves and 5 shelf positions maximise oven space
- Removable oven base for easy cleaning
- Double insulated doors, side and back panels for safe operation, efficiency and economy



4 burner gas range								
MODEL	PRICE £	PRICE €	H	W	D	POWER	WT	
OG8001/N	£3652	€4382	920	600	800	36.8kW	112	
OG8001/P	£3652	€4382	920	600	800	33.6kW	112	
OG8001/N/RHD	£4570	€5256	920	600	800	36.8kW	131	
OG8001/P/RHD	£4570	€5256	920	600	800	33.6kW	131	
Internal usable dimensions			405	495	530			

6 burner gas range								
MODEL	PRICE £	PRICE €	H	W	D	POWER	WT	
OG8002/N	£3914	€4697	920	900	800	55kW	149	
OG8002/P	£3914	€4697	920	900	800	50.5kW	149	
Internal usable dimensions			405	715	530			

6 burner gas range with drop down door								
MODEL	PRICE £	PRICE €	H	W	D	POWER	WT	
OG8002/N/DD	£4610	€5302	920	900	800	55kW	172	
OG8002/P/DD	£4610	€5302	920	900	800	50.5kW	172	
Internal usable dimensions			405	715	530			

/RHD - right hinged door

MODEL	PRICE £	PRICE €	DESCRIPTION
A OA8901	£471	€542	Splashback/shelf

MODEL	PRICE £	PRICE €	DESCRIPTION
A OA8902	£571	€658	Splashback/shelf

MODEL	PRICE £	PRICE €	DESCRIPTION
A OA8902	£571	€658	Splashback/shelf

Dual Fuel Oven Ranges

Gas open top hob

- 7.5kW dual concentric burners for focused heat distribution from a fast boil to a low simmer
- Individual heavy-duty single cast iron supports, built to withstand the rigours of the busiest kitchen
- Flame failure protection
- Low flue to allow use of the complete hob top
- Drip tray

Inclusive Accessories

- 3 chrome plated shelves

Oven

- 4kW (OD8006) and 6kW (OD8007) ovens
- Precise thermostatic control from 130°C to 250°C
- Twin fan assisted oven for uniform heat and consistent cooking results (OD8006 single fan only)
- Large capacity oven, 3 x GN1/1 (OD8006) and 6 x GN1/1 (OD8007)
- 3 shelves and 5 shelf positions maximize oven space
- Removable oven base for easy cleaning
- Double insulated doors, side and back panels for safe operation, efficiency and economy



2 YEAR UK parts and labour warranty | Export parts warranty on all Lincat products



Key
 H = Height (mm)
 W = Width (mm)
 D = Depth (mm)
 WT = Packed Weight in kg

4 burner dual fuel range								
MODEL	PRICE £	PRICE €	H	W	D	POWER	OVEN POWER	WT
*OD8006/N	£5303	€6099	912	600	800	30kW	4kW	167
*OD8006/P	£5303	€6099	912	600	800	26.8kW	4kW	167
Internal usable dimensions			410	525	530			

6 burner dual fuel range								
MODEL	PRICE £	PRICE €	H	W	D	POWER	OVEN POWER	WT
*OD8007/N	£7154	€8227	912	900	800	45kW	6kW	201
*OD8007/P	£7154	€8227	912	900	800	40.2kW	6kW	201
Internal usable dimensions			410	825	530			

MODEL	PRICE £	PRICE €	DESCRIPTION
A OA8984	£471	€542	Splashback/shelf

MODEL	PRICE £	PRICE €	DESCRIPTION
A OA8985	£571	€658	Splashback/shelf

* Please refer to pages L117 to L118 for electricity supply requirements

OPUS 800

Gas Solid Top Range

Gas solid top

- Powerful burner produces consistent heat gradient throughout the plate
- Flame failure protection
- 3 piece, heavy duty cast iron top with removable bull's eye
- Profiled underside of cast iron top for optimum heat circulation
- Low flue to allow use of the complete hob top

Oven

- Precise thermostatic control from 120°C to 260°C
- Large capacity oven, 4 x GN1/1
- 2 shelves and 4 shelf positions maximise oven space
- Removable oven base for easy cleaning
- Double insulated doors, side and back panels for safe operation, efficiency and economy

Inclusive Accessories

- 2 chrome plated shelves
- Bull's eye lifting poker



2 YEAR UK parts and labour warranty | Export parts warranty on all Lincat products

Electric Solid Top Range

Electric solid top

- Twin zone full width heavy-duty hot plate maximises cooking space
- Two 2.7kW and two 2kW elements produce controllable heat gradient throughout the cast iron plate - use the central areas for rapid boiling and outer areas for simmering and holding

Oven

- 6kW oven
- Precise thermostatic control from 50°C to 250°C
- Twin fan assisted oven for uniform heat and consistent cooking results
- Large capacity oven, 6 x GN1/1
- 3 shelves and 5 shelf positions maximise oven space

Inclusive Accessories

- 3 chrome plated shelves



Solid top gas range							
MODEL	PRICE £	PRICE €	H	W	D	POWER	WT
OG8005/N	£5150	€6180	900	900	800	18.5kW	173
OG8005/P	£5150	€6180	900	900	800	19kW	173
Internal usable dimensions			405	715	530		

Solid top gas range with drop down door							
MODEL	PRICE £	PRICE €	H	W	D	POWER	WT
OG8005/N/DD	£7118	€8186	900	900	800	18.5kW	173
OG8005/P/DD	£7118	€8186	900	900	800	19kW	173
Internal usable dimensions			405	715	530		

Solid top electric range							
MODEL	PRICE £	PRICE €	H	W	D	POWER	WT
*OE8015	£7886	€9070	900	900	800	15.4kW	201
Internal usable dimensions			405	825	530		

MODEL	PRICE £	PRICE €	DESCRIPTION
A OA8980	£565	€650	Splashback/shelf

MODEL	PRICE £	PRICE €	DESCRIPTION
A OA8980	£565	€650	Splashback/shelf

MODEL	PRICE £	PRICE €	DESCRIPTION
A OA8983	£571	€658	Splashback/shelf

Electric Oven Ranges

Electric hob top

- Heavy-duty cast iron 2.6kW hotplates deliver fast responsive heat
- Choice of round or square hotplates
- Fully pressed sealed hob for easy cleaning

Inclusive Accessories

- 2 chrome plated shelves

Oven

- 4kW (OE8010) and 6kW (OE8008 and OE8016) ovens
- Precise thermostatic control from 50°C to 250°C
- Twin fan assisted oven for uniform heat and consistent cooking results (OE8010 single fan only)
- Large capacity oven, 2 x GN1/1 (OE8010) and 4 x GN1/1 (OE8008 and OE8016)
- 2 shelves and 5 shelf positions maximise oven space
- Removable oven base for easy cleaning
- Double insulated doors, side and back panels for safe operation, efficiency and economy



4 hotplate (square) electric range							
MODEL	PRICE £	PRICE €	H	W	D	POWER	WT
*OE8010	£6115	€7032	925	600	800	14.4kW	109
Internal usable dimensions			405	495	530		

6 hotplate (square) electric range							
MODEL	PRICE £	PRICE €	H	W	D	POWER	WT
*OE8008	£8002	€9203	925	900	800	21.6kW	152
Internal usable dimensions			405	715	512		

6 hotplate (round) electric range							
MODEL	PRICE £	PRICE €	H	W	D	POWER	WT
*OE8016	£6855	€7884	925	900	800	21.6kW	147
Internal usable dimensions			405	715	512		

MODEL	PRICE £	PRICE €	DESCRIPTION
A OA8981	£471	€542	Splashback/shelf

MODEL	PRICE £	PRICE €	DESCRIPTION
A OA8982	£571	€658	Splashback/shelf

MODEL	PRICE £	PRICE €	DESCRIPTION
A OA8982	£571	€658	Splashback/shelf

* Please refer to pages L117 to L118 for electricity supply requirements

OPUS 800

All gas power ratings are nominal values. Gas counter top equipment is supplied on 150mm high legs in compliance with CE legislation. Electric counter top equipment is supplied on height adjustable 55-70mm high legs.

Induction Range

Induction hob

- 5kW induction zones
- 270mm diameter induction cooking zones
- Automatic pan detection function cuts power when no pan is present, preventing harm to users, while saving energy
- 6mm thick high impact resistant glass ceramic surface will withstand hard knocks and is easy to clean
- Multiple internal cooling fans and overheat protection for long service life
- Easy to change filters

Inclusive Accessories

- 2 chrome plated shelves

Oven

- 4kW oven
- Precise thermostatic control from 130°C to 250°C
- Fan assisted oven for uniform heat and consistent cooking results
- Large capacity oven accommodates 2 x GN1/1 containers
- 2 shelves and 5 shelf positions maximize oven space
- Removable oven base for easy cleaning
- Double insulated doors, side and back panels for safe operation, efficiency and economy
- Reduced power options available on request



Lincat

4 zone induction oven range							
MODEL	PRICE £	PRICE €	H	W	D	POWER	WT
*OE8017	£16,360	€18,814	900	900	800	24kW	153
Internal usable dimensions			420	525	510		

MODEL	PRICE £	PRICE €	DESCRIPTION
S FI41	£15.55	€18.85	Air filter

OPUS 800

Gas Boiling Tops

- 7.5kW dual concentric burners for focused heat distribution from a fast boil to a low simmer
- Individual heavy duty single cast iron supports, built to withstand the rigours of the busiest kitchen
- Flame failure protection
- Low flue to allow use of the complete hob top
- Drip tray



2 burner gas boiling top							
MODEL	PRICE £	PRICE €	H	W	D	POWER	WT
OG8009/N	£2099	€2414	412	300	800	15kW	40
OG8009/P	£2099	€2414	412	300	800	13.6kW	40

4 burner gas boiling top							
MODEL	PRICE £	PRICE €	H	W	D	POWER	WT
OG8003/N	£3032	€3487	412	600	800	30kW	64
OG8003/P	£3032	€3487	412	600	800	27.2kW	64

6 burner gas boiling top							
MODEL	PRICE £	PRICE €	H	W	D	POWER	WT
OG8004/N	£3935	€4525	412	900	800	45kW	89
OG8004/P	£3935	€4525	412	900	800	40.8kW	89

MODEL	PRICE £	PRICE €	DESCRIPTION
OA8970	£733	€843	Pedestal with doors
OA8934	£733	€843	Floor stand

MODEL	PRICE £	PRICE €	DESCRIPTION
OA8972	£807	€929	Pedestal with doors
OA8972/C	£807	€929	Pedestal with doors and castors
OA8917	£807	€929	Floor stand
OA8917/C	£807	€929	Floor stand with castors

MODEL	PRICE £	PRICE €	DESCRIPTION
OA8973	£877	€1009	Pedestal with doors
OA8973/C	£877	€1009	Pedestal with doors and castors
OA8914	£877	€1009	Floor stand
OA8914/C	£877	€1009	Floor stand with castors

Electric Boiling Tops

- Heavy duty cast iron 2.6kW hotplates deliver fast responsive heat
- Fully pressed sealed hob for easy cleaning



4 hotplate electric boiling top							
MODEL	PRICE £	PRICE €	H	W	D	POWER	WT
*OE8012	£3540	€4071	325	600	800	10.4kW	73

6 hotplate electric boiling top							
MODEL	PRICE £	PRICE €	H	W	D	POWER	WT
*OE8011	£4625	€5319	325	900	800	15.6kW	84

MODEL	PRICE £	PRICE €	DESCRIPTION
OA8972	£807	€929	Pedestal with doors
OA8972/C	£807	€929	Pedestal with doors and castors
OA8917	£807	€929	Floor stand
OA8917/C	£807	€929	Floor stand with castors
LK11	£63	€74	Long leg kit

MODEL	PRICE £	PRICE €	DESCRIPTION
OA8973	£877	€1009	Pedestal with doors
OA8973/C	£877	€1009	Pedestal with doors and castors
OA8914	£877	€1009	Floor stand
OA8914/C	£877	€1009	Floor stand with castors
LK11	£63	€74	Long leg kit

2 YEAR UK parts and labour warranty | Export parts warranty on all Lincat products

Product Codes
/N = natural gas /P = propane gas Btu/hr = kW x 3412

* Please refer to pages L117 to L118 for electricity supply requirements

OPUS 800

Induction Hobs

- A choice of 3.5kW or 5kW induction zones
- Automatic pan detection function cuts power when no pan is present, preventing harm to users, while saving energy
- 6mm thick high impact resistant glass ceramic surface will withstand hard knocks and is easy to clean
- Multiple internal cooling fans and overheat protection for long service life
- Easy to change filter, built into the base of the unit



Lincat

⚡ 2 zone induction hob (twin)							
MODEL	PRICE £	PRICE €	H	W	D	POWER	WT
*OE8018	£7248	€8335	300	400	800	10.6kW	44
*OE8020	£7248	€8335	300	400	800	7kW	44

MODEL	PRICE £	PRICE €	DESCRIPTION
A OA8971	£761	€875	Pedestal with doors
A OA8921	£761	€875	Floor stand
S FI36	£15.55	€18.85	Air filter
A LK11	£63	€74	Long leg kit

Lincat

⚡ 4 zone induction hob (quad)							
MODEL	PRICE £	PRICE €	H	W	D	POWER	WT
*OE8019	£13,043	€15,000	300	800	800	21.2kW	77
*OE8021	£13,043	€15,000	300	800	800	14kW	77

MODEL	PRICE £	PRICE €	DESCRIPTION
A OA8974	£852	€981	Pedestal with doors
A OA8974/C	£852	€981	Pedestal with doors with castors
A OA8956	£852	€981	Floor stand
A OA8956/C	£852	€981	Floor stand with castors
S FI36	£15.55	€18.85	Air filter
A LK11	£63	€74	Long leg kit

Key

H	= Height (mm)
W	= Width (mm)
D	= Depth (mm)
WT	= Packed Weight in kg

* Please refer to pages L117 to L118 for electricity supply requirements

OPUS 800

All gas power ratings are nominal values.

Oil Management

All Opus 800 series gas and electric fryers are available as a base model with oil drainage through the body of the fryer. A gravity filtration accessory adds in-built filtration to the fryer, and the pumped filtration option provides the ultimate in convenience.

Gravity filtration accessory

The integral gravity filtration accessory converts the base model into a fryer with two-stage gravity filtration. This extends oil life, reduces disposal costs and provides a better tasting product for longer.



Pumped filtration option (/OP)

The integral pumped filtration option enables oil to be filtered and the fryer ready for use again in less than 5 minutes. Oil can be filtered during or after service, even whilst hot, maximising oil life. This eliminates the need to lift heavy containers, reducing contact with hot oil and the chances of hazardous spillages.

This option is supplied with a hose with lance for easy discharge of oil into a waste container.

Twin tank pumped filtration (/OP2)

The /OP2 version for twin tank fryers has two oil pumps and two buckets, which is designed to remove cross contamination of the oil from either side of the fryer.

This option is supplied with 2 hoses with lance for easy discharge of oil into a waste container.



Vortech High Efficiency Gas Fryer

- 97% energy efficiency rating verified in independent BSI tests delivers substantially lower running costs and higher output
- Typical payback within 23 months
- Two stage filtration removes contaminants and particles, extending oil life by up to 75% and so reducing oil costs
- Pumped oil return enables the oil to be filtered and the fryer ready for use again in less than five minutes - safe and convenient
- Oil can be filtered during or after service even whilst hot
- Convenient electronic ignition
- Supplied with a hose with lance for easy discharge of oil into a waste container

Inclusive Accessories

- Batter plate
- Full lid
- Baskets
- Stainless steel bucket



Lincat

Vortech gas fryer								
MODEL	PRICE £	PRICE €	H	W	D	POWER	OIL CAP	WT
OG8115/OP/N	£12,042	€13,849	1070	400	800	22kW	16L	108
OG8115/OP/P	£12,042	€13,849	1070	400	800	22kW	16L	108

Will accept 1 x BA82 basket

MODEL	PRICE £	PRICE €	DESCRIPTION
A BA82	£126	€146	Large fryer basket with doors
A OA8961	£302	€348	Side splashguard (left and right)
A OA8935	£304	€351	Vortech fryer batter tray and holder



Most Opus 800 products are SUPPLIED WITH CASTORS AS STANDARD

Please contact us if you require products to be supplied with legs

Key

H = Height (mm)
W = Width (mm)
D = Depth (mm)
WT = Packed Weight in kg

2 YEAR

UK parts and labour warranty

Export parts warranty

on all Lincat products

OPUS 800

Gas Fryers

- Accurate thermostatic control up to 190°C for consistent results and safe operation
- High energy efficiency
- Convenient piezo ignition
- Externally fired heating gives easy access for cleaning tanks
- Gravity filtration accessory available for all base models
- /OP Pumped filtration option available on all models
- Model OG8111 features two independently controlled fryer tanks for greater versatility
- For safety and stability, 300mm and 400mm wide fryers are supplied with front legs and rear castors

Inclusive Accessories

- Batter plate
- Baskets
- Full lid
- Stainless steel bucket



Single tank gas fryer (300mm wide)								
MODEL	PRICE £	PRICE €	H	W	D	POWER	OIL CAP	WT
OG8110/N	£4522	€5201	1020	300	815	16kW	14L	83
OG8110/P	£4522	€5201	1020	300	815	16kW	14L	83
‡OG8110/OP/N	£8134	€9355	1070	300	815	16kW	14L	96
‡OG8110/OP/P	£8134	€9355	1070	300	815	16kW	14L	96

Supplied with 1 x BA165 basket

MODEL	PRICE £	PRICE €	DESCRIPTION
A OA8955	£302	€348	Side splashguard (left and right)
A OF1	£238	€274	Gravity filtration kit (OG810 only)

Single tank gas fryer (400mm wide)								
MODEL	PRICE £	PRICE €	H	W	D	POWER	OIL CAP	WT
OG8106/N	£4659	€5359	1020	400	800	23kW	16L	98
OG8106/P	£4659	€5359	1020	400	800	23kW	16L	98
‡OG8106/OP/N	£8146	€9368	1070	400	800	23kW	16L	104
‡OG8106/OP/P	£8146	€9368	1070	400	800	23kW	16L	104

Supplied with 2 x BA159 baskets

MODEL	PRICE £	PRICE €	DESCRIPTION
A BA82	£126	€146	Large fryer basket (will accept x 1)
A OA8955	£302	€348	Side splashguard (left and right)
A OF2	£272	€314	Gravity filtration kit (OG8106 only)



Single tank gas fryer (600mm wide)								
MODEL	PRICE £	PRICE €	H	W	D	POWER	OIL CAP	WT
OG8107/N	£5303	€6099	1020	600	800	30kW	25L	125
OG8107/P	£5303	€6099	1020	600	800	30kW	25L	125
‡OG8107/OP/N	£8789	€10,108	1070	600	800	30kW	25L	135
‡OG8107/OP/P	£8789	€10,108	1070	600	800	30kW	25L	135

Supplied with 2 x BA82 baskets

MODEL	PRICE £	PRICE €	DESCRIPTION
A BA159	£147	€169	Large fryer basket (will accept x 1)
A OA8955	£302	€348	Side splashguard (left and right)
A OF2	£272	€314	Gravity filtration kit (OG8107 only)

Twin tank gas fryer (600mm wide)								
MODEL	PRICE £	PRICE €	H	W	D	POWER	OIL CAP	WT
OG8111/N	£6753	€7767	1020	600	800	32kW	2 x 14L	142
OG8111/P	£6753	€7767	1020	600	800	32kW	2 x 14L	142
‡OG8111/OP/N	£10,242	€11,779	1070	600	800	32kW	2 x 14L	151
‡OG8111/OP/P	£10,242	€11,779	1070	600	800	32kW	2 x 14L	151
‡OG8111/OP2/N	£13,028	€14,983	1070	600	800	32kW	2 x 14L	157
‡OG8111/OP2/P	£13,028	€14,983	1070	600	800	32kW	2 x 14L	157

Supplied with 2 x BA165 baskets



Gas fryers with pumped filtration (/OP & /OP2) require a 1 phase connection

Product Codes

/N = natural gas /P = propane gas Btu/hr = kW x 3412

‡No electricity supply required (except with /OP and /OP2 models)

Electric Fryers

- Accurate thermostatic control up to 190°C for consistent results and safe operation
- Hinged, lift out element, with safety interlock for easy tank access and cleaning
- Models OE8105 and OE8113 feature two independently controlled fryer tanks for greater versatility
- Gravity filtration accessory available for all base models
- /OP Pumped filtration option available on all models
- For safety and stability, 300mm and 400mm wide fryers are supplied with front legs and rear castors

Inclusive Accessories

- Batter plate
- Baskets
- Full lid
- Stainless steel bucket



Single tank electric fryer (300mm wide)								
MODEL	PRICE £	PRICE €	H	W	D	POWER	OIL CAP	WT
*OE8112	£3389	€3898	1020	300	800	12kW	15L	72
*OE8112/OP	£6845	€7872	1070	300	800	12kW	15L	79

Supplied with 1 x BA82 basket

Single tank electric fryer (400mm wide)								
MODEL	PRICE £	PRICE €	H	W	D	POWER	OIL CAP	WT
*OE8114	£4301	€4947	1020	400	800	14kW	19L	81
*OE8114/OP	£7728	€8887	1070	400	800	14kW	19L	90

Supplied with 2 x BA83 baskets

Twin tank electric fryer (400mm wide)								
MODEL	PRICE £	PRICE €	H	W	D	POWER	OIL CAP	WT
*OE8105	£4865	€5595	1020	400	800	14kW	2 x 9.5L	87
*OE8105/OP	£8121	€9340	1070	400	800	14kW	2 x 9.5L	97
*OE8105/OP2	£10,900	€12,536	1070	400	800	14kW	2 x 9.5L	101

Supplied with 2 x BA83 baskets

MODEL	PRICE £	PRICE €	DESCRIPTION
A BA122	£130	€150	Small fryer basket (will accept x 2)
A OA8954	£302	€348	Side splashguard (left and right)
A OF1	£238	€274	Gravity filtration kit (OE8112 only)

MODEL	PRICE £	PRICE €	DESCRIPTION
A OA8954	£302	€348	Side splashguard (left and right)
A OF2	£272	€314	Gravity filtration kit (OE8114 only)

MODEL	PRICE £	PRICE €	DESCRIPTION
A OA8954	£302	€348	Side splashguard (left and right)
A OF2	£272	€314	Gravity filtration kit (OE8105 only)



2 YEAR

UK parts and labour warranty

Export parts warranty

on all Lincat products

Single tank electric fryer (600mm wide)								
MODEL	PRICE £	PRICE €	H	W	D	POWER	OIL CAP	WT
*OE8108	£4995	€5745	1020	600	800	22kW	36.5L	109
*OE8108/OP	£8402	€9663	1070	600	800	22kW	36.5L	115

Supplied with 2 x BA82 basket

Twin tank electric fryer (600mm wide)								
MODEL	PRICE £	PRICE €	H	W	D	POWER	OIL CAP	WT
*OE8113	£5392	€6201	1020	600	800	24kW	2 x 15L	111
*OE8113/OP	£8785	€10,104	1070	600	800	24kW	2 x 15L	118
*OE8113/OP2	£11,615	€13,358	1070	600	800	24kW	2 x 15L	131

Supplied with 2 x BA82 basket

MODEL	PRICE £	PRICE €	DESCRIPTION
A BA83	£140	€161	Small fryer basket (will accept x 3)
A OA8954	£302	€348	Side splashguard (left and right)
A OF2	£272	€314	Gravity filtration kit (OE8108 only)

MODEL	PRICE £	PRICE €	DESCRIPTION
A BA122	£130	€150	Small fryer basket (will accept x 4)
A OA8954	£302	€348	Side splashguard (left and right)
A OF2	£272	€314	Gravity filtration kit (OE8113 only)

Key

H = Height (mm)
W = Width (mm)
D = Depth (mm)
WT = Packed Weight in kg

* Please refer to pages L117 to L118 for electricity supply requirements

OPUS 800

All gas power ratings are nominal values.

Gas Salamander Grills

- Powerful, highly efficient ceramic plaque burners for reliability and rapid heat up
- Three independently controlled heat zones on the OG8302 for maximum versatility
- Four shelf positions with horizontal or angled settings
- OG8302 is GN 1/1 compatible
- Enamelled front for durability
- Flame failure protection

Inclusive Accessories

- Reversible cast aluminium branding plate, with removable fat collection container (OG8302 only)

Electric Salamander Grills

- Powerful heating elements, for reliability and rapid heat up
- Left and right independently controlled heat zones on the OE8303 for maximum versatility
- Four shelf positions with horizontal or angled settings
- OE8303 is GN 1/1 compatible
- Enamelled front for durability

Inclusive Accessories

- Reversible cast aluminium branding plate, with removable fat collection container (OE8303 only)



Gas salamander							
MODEL	PRICE £	PRICE €	H	W	D	POWER	WT
OG8301/N	£2508	€2884	450	800	438	6kW	48
OG8301/P	£2508	€2884	450	800	438	6.8kW	48

Gas salamander							
MODEL	PRICE £	PRICE €	H	W	D	POWER	WT
OG8302/N	£3971	€4568	495	900	548	8.7kW	73
OG8302/P	£3971	€4568	495	900	548	9kW	73

Electric salamander							
MODEL	PRICE £	PRICE €	H	W	D	POWER	WT
*OE8304	£2213	€2546	400	800	415	4.4kW	46

Electric salamander							
MODEL	PRICE £	PRICE €	H	W	D	POWER	WT
*OE8303	£3344	€3845	510	890	520	5.4kW	72

MODEL	PRICE £	PRICE €	DESCRIPTION
A OA8907	£765	€880	Floor stand for OG8301
A OA8912	£852	€981	Floor stand for OG8302
A OA8908	£555	€638	Bench stand for OG8301
A OA8918	£600	€691	Bench stand for OG8302
A OA8909	£252	€290	Wall bracket for OG8301
A OA8911	£311	€358	Wall bracket for OG8302
A OA8976	£260	€299	Branding plate for OG8301
A BR10	£345	€397	Additional branding plate for OG8302

Salamander floor stands cannot be supplied with castors

MODEL	PRICE £	PRICE €	DESCRIPTION
A OA8907	£765	€880	Floor stand for OE8304
A OA8912	£852	€981	Floor stand for OE8303
A OA8908	£555	€638	Bench stand for OE8304
A OA8918	£600	€691	Bench stand for OE8303
A OA8909	£252	€290	Wall bracket for OE8304
A OA8911	£311	€358	Wall bracket for OE8303
A OA8976	£260	€299	Branding plate for OE8304
A BR10	£345	€397	Additional branding plate for OE8303

Salamander floor stands cannot be supplied with castors

Electric Cook & Hold Salamander

The sophisticated Cook & Hold Salamander heats up in just eight seconds when the plate detection mechanism is activated by a plate or gastronorm pan. Once the food is cooked, the hold function will ensure food is kept warm but does not continue to cook until required for service. Once the plate is removed and the plate detection mechanism freed, the elements automatically switch off saving energy.

- Cook and hold function
- Fast heat up 'Hi-Light' elements – ready to cook in just eight seconds
- Self-balancing height adjustable grill hood for easy operation
- Three independently controlled heating zones for maximum flexibility
- Touchpad control with digital display of time and power settings
- 20 minute audible timer
- GN1/1 compatible
- Suitable for wall or bench mounting
- Suitable for single or three phase installation

2 YEAR UK parts and labour warranty | Export parts warranty
on all Lincat products



Lincat

Electric cook and hold salamander							
MODEL	PRICE £	PRICE €	H	W	D	POWER	WT
*OE8306	£4608	€5299	544	600	562	4.5kW	89

Supplied on height adjustable 25-45mm high legs

MODEL	PRICE £	PRICE €	DESCRIPTION
A BR75	£263	€303	Wall bracket

* Please refer to pages L117 to L118 for electricity supply requirements

OPUS 800

All gas power ratings are nominal values. Gas counter top equipment is supplied on 150mm high legs in compliance with CE legislation. Electric counter top equipment is supplied on height adjustable 55-70mm high legs.

Gas Griddles

- Maximised cooking area, griddle plates sit flush to the sides of the unit
- Left and right independently controlled heat zones for flexibility and economy during quiet periods
- Precise thermostatic control from 90°C - 280°C for consistent results and economical operation
- Half-ribbed plate option (R), for attractive branding presentation marks
- Chrome plate option (C), easy to clean and reduced heat radiation for a comfortable working environment and reduced energy costs
- Convenient piezo ignition and pilot burners for stand-by operation
- Flame failure protection

Inclusive Accessories

- Scraper (not for chrome models)



Gas griddles (machined steel)							
MODEL	PRICE £	PRICE €	H	W	D	POWER	WT
OG8201/N	£3605	€4326	532	600	800	15.5kW	93
OG8201/P	£3605	€4326	532	600	800	15.5kW	93
OG8202/N	£4326	€5192	532	900	800	23kW	124
OG8202/P	£4326	€5192	532	900	800	23kW	124

Gas griddles (chrome)							
MODEL	PRICE £	PRICE €	H	W	D	POWER	WT
OG8201/C/N	£6555	€7539	532	600	800	15.5kW	93
OG8201/C/P	£6555	€7539	532	600	800	15.5kW	93
OG8202/C/N	£7675	€8827	532	900	800	23kW	124
OG8202/C/P	£7675	€8827	532	900	800	23kW	124

Gas griddles (half-ribbed steel)							
MODEL	PRICE £	PRICE €	H	W	D	POWER	WT
OG8201/R/N	£4589	€5278	532	600	800	15.5kW	90
OG8201/R/P	£4589	€5278	532	600	800	15.5kW	90
OG8202/R/N	£5281	€6074	532	900	800	23kW	140
OG8202/R/P	£5281	€6074	532	900	800	23kW	140

MODEL	PRICE £	PRICE €	DESCRIPTION
A OA8972	£807	€929	Pedestal with doors for OG8201
A OA8972/C	£807	€929	Pedestal with doors and castors for OG8201
A OA8917	£807	€929	Floor stand for OG8201
A OA8917/C	£807	€929	Floor stand with castors for OG8201
A OA8973	£877	€1009	Pedestal with doors for OG8202
A OA8973/C	£877	€1009	Pedestal with doors and castors for OG8202
A OA8914	£877	€1009	Floor stand for OG8202
A OA8914/C	£877	€1009	Floor stand with castors for OG8202

Electric Griddles

- Maximised cooking area, griddle plates sit flush to the sides of the unit
- Left and right independently controlled heat zones for flexibility and economy during quiet periods
- Precise thermostatic control from 90°C - 300°C for consistent results and economical operation
- Half-ribbed plate option (R), for attractive branding presentation marks
- Chrome plate option (C), easy to clean and reduced heat radiation for a comfortable working environment and reduced energy costs

Inclusive Accessories

- Scraper (not for chrome models)



Electric griddles (machined steel)							
MODEL	PRICE £	PRICE €	H	W	D	POWER	WT
*OE8205	£2975	€3422	428	600	800	8kW	93
*OE8206	£3524	€4054	428	900	800	12kW	128

Electric griddles (chrome)							
MODEL	PRICE £	PRICE €	H	W	D	POWER	WT
*OE8205/C	£5301	€6069	428	600	800	8kW	95
*OE8206/C	£6373	€7330	428	900	800	12kW	134

Electric griddles (half-ribbed steel)							
MODEL	PRICE £	PRICE €	H	W	D	POWER	WT
*OE8205/R	£3334	€3834	428	600	800	8kW	92
*OE8206/R	£3979	€4577	428	900	800	12kW	124

MODEL	PRICE £	PRICE €	DESCRIPTION
A OA8972	£807	€929	Pedestal with doors for OE8205
A OA8972/C	£807	€929	Pedestal with doors and castors for OE8205
A OA8917	£807	€929	Floor stand for OE8205
A OA8917/C	£807	€929	Floor stand with castors for OE8205
A OA8973	£877	€1009	Pedestal with doors for OE8206
A OA8973/C	£877	€1009	Pedestal with doors and castors for OE8206
A OA8914	£877	€1009	Floor stand for OE8206
A OA8914/C	£877	€1009	Floor stand with castors for OE8206

Electric Clam Griddles

Opus 800 clam griddles cook food up to three times as quickly as a standard griddle. Double griddle plates heat both sides of the food simultaneously, delivering fast, even and repeatable results

- Precise thermostatic temperature control for consistent results and economical operation
- Independently controlled cooking zones for greater flexibility and economy during quieter periods

- Digital timer on each clam plate ensures repeatable results
- Ribbed plate option (R), for attractive branding presentation marks

Inclusive Accessories

- Scraper
- PTFE non-stick sheets

Key

- H = Height (mm)
- W = Width (mm)
- D = Depth (mm)
- WT = Packed Weight in kg



Electric clam griddles (flat upper plate)							
MODEL	PRICE £	PRICE €	H	W	D	POWER	WT
*OE8211	£9431	€10,846	542	400	800	8.6kW	95
*OE8210	£14,882	€17,115	542	800	800	17.2kW	192

Electric clam griddles (ribbed upper plate)							
MODEL	PRICE £	PRICE €	H	W	D	POWER	WT
*OE8211/R	£9492	€10,916	542	400	800	8.6kW	94
*OE8210/R	£14,935	€17,176	542	800	800	17.2kW	167

Electric clam griddles (1 x flat and 1 x ribbed upper plate)							
MODEL	PRICE £	PRICE €	H	W	D	POWER	WT
*OE8210/FR	£14,995	€17,246	542	800	800	17.2kW	170

MODEL	PRICE £	PRICE €	DESCRIPTION
A OA8960	£61	€71	Plate height adjuster (per plate)
A TFS01	£34	€40	Teflon sheet top plate
S TFS02	£23	€27	Teflon sheet hangers (1 pair)
S TFS03	£33	€39	Teflon sheet base plate 800mm wide (1 sheet)
S TFS04	£20	€23	Teflon sheet base plate 400mm wide (1 sheet)
A OA8971	£761	€875	Pedestal with doors for OE8211
A OA8921	£761	€875	Floor stand for OE8211
A OA8974	£852	€981	Pedestal with doors for OE8210
A OA8974/C	£852	€981	Pedestal with doors and castors for OE8210
A OA8956	£852	€981	Floor stand for OE8210
A OA8956/C	£852	€981	Floor stand with castors for OE8210
A OA8988	£79	€91	Clam adjustment bars 17mm

* Please refer to pages L117 to L118 for electricity supply requirements

NEW

The electric chargrill with real flame-grilled technology

BLIND TASTE
TEST RESULTS:
PEOPLE PREFER
IGNITE*

USES
**41%
LESS**
ENERGY**

3x
FASTER
CLEANING**

23%
MORE USABLE
COOKING
SPACE**



Hungry for proof?

Scan the QR code to book
your demo today!



OPUS

IGNITE

Flame grilled taste, Electrified

*Compared to a Gas Chargrill

**Compared to a Direct Cook Chargrill

OPUS 800

Ignite Electric Chargrill

- Real flame grilled technology for a charred taste
- Available in 600, 850 and 1100mm widths
- Removable, heavy-duty segmented cast iron grids deliver attractive branding marks
- Enameled base plate beneath grids for easy cleaning
- Vapourising technology turns fat and debris into ash for simple sweep-out cleaning
- Independently controlled cook zones to meet varying service demands
- Three-piece stainless steel splashback for easier cleaning
- Designed to complement the Opus 800 series
- Supplied with legs and locating cups for secure placement on a Chef Base
- Grid lifting tool and cleaning rake included as standard
- Optional single resting rack
- Optional garnish rail to hold GN 1/9 pots
- Optional stand available for flexible installation



Lincat

Ignite Electric Chargrill (600mm wide)							
MODEL	PRICE £	PRICE €	H	W	D	POWER	WT
*OE8415	£4326	€5191	700	600	800	7.2kW	62
Usable cook area			500	600			



Lincat

Ignite Electric Chargrill (850mm wide)							
MODEL	PRICE £	PRICE €	H	W	D	POWER	WT
*OE8416	£6674	€8008	700	850	800	10.8kW	88
Usable cook area			750	600			



Lincat

Ignite Electric Chargrill (1100mm wide)							
MODEL	PRICE £	PRICE €	H	W	D	POWER	WT
*OE8417	£POA	€POA	700	1100	800	14.4kW	113
Usable cook area			1000	600			

What's in the box?

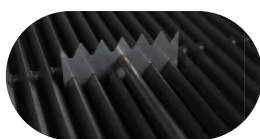

Grid Scraper

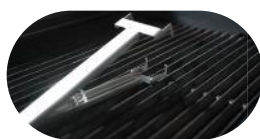
Scissor Action
Grid Lifting Tool

Dustpan and Brush

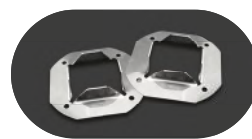

Locating Cups

2

YEAR

UK parts
and labour
warranty

Export
parts
warranty

on all Lincat
products

Optional Accessories



Resting Rack



Garnish Rail

Floor Stand
with Castors

MODEL	PRICE £	PRICE €	DESCRIPTION
A OA9024	£93	€107	Grid Scraper
A OA9023	£93	€107	Scissor Action Grid Lifting Tool
A OA9020	£77	€89	Locating Cups
**A OA8989	£600	€691	Single Resting Rack
A OA9002	£263	€303	Garnish Rail for OE8415
A OA9018	£280	€322	Garnish Rail for OE8416
A OA9019	£POA	€POA	Garnish Rail for OE8417
A OA8917/C	£807	€929	Floor Stand with Castors for OE8415
A OA9016/C	£877	€1009	Floor Stand with Castors for OE8416
A OA9017/C	£POA	€POA	Floor Stand with Castors for OE8417

* Please refer to pages L117 to L118 for electricity supply requirements

** Also ideal for cooking garlic breads and bacon
For OE8415 (600mm) & OE8416 (850mm), 1 required.
For OE8417 (1100mm), 2 required.



Lincat
GREEN RANGE

Lincat

lincat.co.uk

2026

OPUS 800

All gas power ratings are nominal values. Gas counter top equipment is supplied on 150mm high legs in compliance with CE legislation. Electric counter top equipment is supplied on height adjustable 55-70mm high legs.

Gas Chargrills

- Powerful, highly efficient infra-red ceramic plaque burners for fast cooking and significant energy efficiency
- Independently controlled multiple heat zones (3 in OG8401, 5 in OG8402, 7 in OG8403) for maximum versatility
- Flame failure protection
- Heavy-duty cast iron branding grids with reversible design, for uninterrupted cooking and self cleaning at maximum power
- Unique design of radiants, deliver the ideal amount of flaring for that delicious chargrilled taste, without the mess of lava rock or charcoal
- Heavy duty radiant caps (consumable items) protect burners

Inclusive Accessories

- Branding grid scraper
- Cleaning spatula



Lincat



Lincat



Lincat

Gas chargrill (600mm wide)							
MODEL	PRICE £	PRICE €	H	W	D	POWER	WT
OG8401/N	£3502	€4203	653	600	806	13.8kW	92
OG8401/P	£3502	€4203	653	600	806	12.6kW	92

MODEL	PRICE £	PRICE €	DESCRIPTION
A OA8950	£807	€929	Floor stand for OG8401
A OA8950/C	£807	€929	Floor stand with castors for OG8401
A OA8989	£600	€691	Holding shelf for OG8401

Gas chargrill (900mm wide)							
MODEL	PRICE £	PRICE €	H	W	D	POWER	WT
OG8402/N	£3920	€4703	653	900	806	23kW	133
OG8402/P	£3920	€4703	653	900	806	23kW	133

MODEL	PRICE £	PRICE €	DESCRIPTION
A OA8951	£877	€1009	Floor stand for OG8402
A OA8951/C	£877	€1009	Floor stand with castors for OG8402
A OA8990	£807	€929	Holding shelf for OG8402

Gas chargrill (1200mm wide)							
MODEL	PRICE £	PRICE €	H	W	D	POWER	WT
OG8403/N	£5150	€6180	653	1200	806	32.2kW	173
OG8403/P	£5150	€6180	653	1200	806	29.4kW	173

MODEL	PRICE £	PRICE €	DESCRIPTION
A OA8952	£1060	€1220	Floor stand for OG8403
A OA8989	£600	€691	Holding shelf for OG8403

Product Codes

/N = natural gas /P = propane gas Btu/hr = kW x 3412

OPUS 800

Electric counter top equipment is supplied on height adjustable 55-70mm high legs.

Electric Chargrills

- Removable, durable, segmented cast iron grids impart attractive branding marks to food
- Independently controlled multiple heat zones (3 in OE8405, and 6 in OE8406) for maximum versatility • Controlled flaring gives that distinctive chargrilled flavour
- Hinging, interlocked elements and integral water bath makes cleaning easier
- Water bath provides humidity, keeping food succulent and reducing shrinkage

- Plumbed to water supply for quick and easy filling of water bath with alternative manual-fill facility
- High temperature safety cut-out for protection if water bath runs dry

Inclusive Accessories

- Grid cleaning tool
- Branding iron lifting rod



Electric chargrill (600mm wide)							
MODEL	PRICE £	PRICE €	H	W	D	POWER	WT
*OE8405	£3296	€3956	415	600	817	8.4kW	69

Electric chargrill (900mm wide)							
MODEL	PRICE £	PRICE €	H	W	D	POWER	WT
*OE8406	£3904	€4685	415	900	817	12.4kW	73

MODEL	PRICE £	PRICE €	DESCRIPTION
A LT03	£27	€33	Loading tool
A OA8972	£807	€929	Pedestal with doors
A OA8972/C	£807	€929	Pedestal with doors and castors
A OA8917	£807	€929	Floor stand
A OA8917/C	£807	€929	Floor stand with castors
A OA8986	£735	€845	Keep warm shelf
A OA8987	£193	€223	Condiment holder
A OA8959	£81	€93	Tool holder accessory

MODEL	PRICE £	PRICE €	DESCRIPTION
A LT03	£27	€33	Loading tool
A OA8973	£877	€1009	Pedestal with doors
A OA8973/C	£877	€1009	Pedestal with doors and castors
A OA8914	£877	€1009	Floor stand
A OA8914/C	£877	€1009	Floor stand with castors
A OA8959	£81	€93	Tool holder accessory Suitable accessory for all Opus 800 products

Electric Direct Cook Chargrills

- Create perfectly cooked, expertly branded burgers and steaks
- As food is cooked directly on the elements, there's no need for separate branding bars or grids
- Powerful elements are designed for rapid heat-up and a consistent temperature across the whole cooking surface
- Independently-controlled elements on the OE8414 mean one side can be switched off during quieter service periods to save energy

- After service, the unit can be turned on full power for 15 minutes to burn off fat and debris. After this, any remaining debris can be removed using the tool supplied
- Fully removable tank liner for easy cleaning.



Electric chargrill (600mm wide)							
MODEL	PRICE £	PRICE €	H	W	D	POWER	WT
*OE8413	£4326	€5192	592	600	800	8.4kW	69

Electric chargrill (900mm wide)							
MODEL	PRICE £	PRICE €	H	W	D	POWER	WT
*OE8414	£6474	€7769	592	900	800	13.4kW	90

MODEL	PRICE £	PRICE €	DESCRIPTION
A OA9010	£807	€929	Floor stand
A OA9010/C	£807	€929	Floor stand with castors
A OA8989	£600	€691	Keep warm shelf
A OA9002	£263	€303	Condiment holder
A OA9008	£27	€31	Scraper

MODEL	PRICE £	PRICE €	DESCRIPTION
A OA9011	£797	€916	Floor stand
A OA9011/C	£797	€916	Floor stand with castors
A OA8990	£807	€929	Keep warm shelf
A OA9003	£280	€322	Condiment holder
A OA9008	£27	€31	Scraper

* Please refer to pages L117 to L118 for electricity supply requirements

OPUS 800

All gas power ratings are nominal values.

Electric Pasta Boiler

- Two position water setting: fast fill, or trickle fill for maintaining water level while cooking
- Boil dry protection
- Starch removal system keeps water fresh
- Direct overflow connection and water replenishment
- Direct connection to water supply and waste
- Units are supplied without pasta baskets, choice of optional high quality pasta baskets for convenience and flexibility
- Can be used as a pasta boiler, steamer or bain marie, saving valuable space
- For safety and stability this product is supplied with front legs and rear castors

2

YEAR

UK parts
and labour
warranty

Export
parts
warranty

on all Lincat
products

Electric pasta boiler						
MODEL	PRICE £	PRICE €	H	W	D	POWER WT
*OE8701	£4101	€4717	1020	400	800	6kW 67

Price does not include basket

Pasta baskets

MODEL	PRICE £	PRICE €	DESCRIPTION	NO. REQUIRED
A OA8922	£267	€307	Large pasta basket	1
A OA8924	£195	€225	Half pasta basket	2
A OA8925	£145	€166	Quarter pasta basket	4

Gastronorm containers (150mm deep) and lids for operation as a bain marie

MODEL	PRICE £	PRICE €	DESCRIPTION	NO. REQUIRED
A OA8926	£250	€288	GN 1/1 container	1
A OA8927	£152	€176	GN 1/2 container	2
A OA8928	£153	€177	GN 1/3 container	3

Perforated gastronorm containers (140mm deep) and lids for operation as a steamer

MODEL	PRICE £	PRICE €	DESCRIPTION	NO. REQUIRED
A OA8931	£306	€353	GN 1/1 perforated container	1
A OA8932	£211	€243	GN 1/2 perforated container	2



OPUS 800

Electric counter top equipment is supplied on height adjustable 55-70mm high legs.

Electric Bain Marie

- Compatible with standard GN 1/1 containers
- Optional gastronorm packs enable you to tailor the unit to your requirements
- Robust front mounted tap for easy drainage
- Unique, easy-to-clean flush fitting plate element
- Boil dry protection feature prevents element from overheating and failing
- Accurate thermostatic control maintains food at a constant safe temperature



Electric bain marie							
MODEL	PRICE £	PRICE €	H	W	D	POWER	WT
OE8601	£1777	€2044	300	400	800	1.8kW	25

MODEL	PRICE £	PRICE €	DESCRIPTION
A OA8926	£250	€288	GN 1/1 container (150mm deep) and lids (1 required)
A OA8927	£152	€176	GN 1/2 container (150mm deep) and lids (2 required)
A OA8928	£153	€177	GN 1/3 container (150mm deep) and lids (3 required)
A OA8971	£761	€875	Pedestal with doors
A OA8921	£761	€875	Floor stand
A LK11	£63	€74	Long leg kit

Electric Chip Scuttle

- Heated from above and below to keep chips and other deep-fried products in perfect condition
- Removable perforated fat drain plate helps to keep deep-fried products fresh and crisp
- Overhead heat lamp enhances presentation with an attractive warm glow
- Removable chip container is quick and easy to clean

Inclusive Accessories

- 1/1 GN container with perforated fat drain plate



Electric chip scuttle							
MODEL	PRICE £	PRICE €	H	W	D	POWER	WT
OE8109	£1987	€2286	825	400	800	1.5kW	48

MODEL	PRICE £	PRICE €	DESCRIPTION
A OA8971	£761	€875	Pedestal with doors
A OA8921	£761	€875	Floor stand
A LK11	£63	€74	Long leg kit

Worktops

- Provides useful workspace
- Designed to suite with Opus 800 equipment
- Can be mounted on a floor stand or pedestal with doors



Worktops							
MODEL	PRICE £	PRICE €	H	W	D	WT	
OA8919	£708	€815	300	300	800	17	
OA8938	£743	€855	300	400	800	22	
OA8936	£758	€872	300	600	800	26	
OA8939	£787	€906	300	800	800	33	
OA8940	£812	€935	300	900	800	36	

* Please refer to pages L117 to L118 for electricity supply requirements

OPUS 800

Electric counter top equipment is supplied on height adjustable 55-70mm high legs.

Pedestals with Doors and Floor Stands

Pedestals with doors

- Suitable for Opus 800 series counter top models**
- 300mm, 400mm, 600mm, 800mm and 900mm widths available
- Cupboard with side hinged doors

Floor stands

- Suitable for Opus 800 series counter top models**
- 300mm, 400mm, 600mm, 800mm and 900mm widths available

2
YEAR

UK parts
and labour
warranty

Export
parts
warranty

on all Lincat products



Also available with castors



Pedestals

MODEL	PRICE £	PRICE €	DESCRIPTION
A OA8970	£733	€843	Pedestal with doors for units 300mm wide
A OA8971	£761	€875	Pedestal with doors for units 400mm wide
A OA8972	£807	€929	Pedestal with doors for units 600mm wide
A OA8972/C	£807	€929	Pedestal with doors and castors for units 600mm wide
A OA8974	£852	€981	Pedestal with doors for units 800mm wide
A OA8974/C	£852	€981	Pedestal with doors and castors for units 800mm wide
A OA8973	£877	€1009	Pedestal with doors for units 900mm wide
A OA8973/C	£877	€1009	Pedestal with doors and castors for units 900mm wide

Floor stands

MODEL	PRICE £	PRICE €	DESCRIPTION
A OA8934	£733	€843	Floor stand for units 300mm wide
A OA8921	£761	€875	Floor stand for units 400mm wide
A OA8917	£807	€929	Floor stand for units 600mm wide
A OA8917/C	£807	€929	Floor stand with castors for units 600mm wide
A OA8956	£852	€981	Floor stand for units 800mm wide
A OA8956/C	£852	€981	Floor stand with castors for units 800mm wide
A OA8914	£877	€1009	Floor stand for units 900mm wide
A OA8914/C	£877	€1009	Floor stand with castors for units 900mm wide

CONVECTOR



Convector Convection Oven: fast, efficient and effective

Able to roast, braise, bake and reheat, a Convector convection oven is a powerful addition to any commercial kitchen. Ideal for roasts, casseroles, bread, cakes and pastry, it can produce supremely even results even when fully loaded, thanks to its bi-directional, two-speed fan and optimised airflow.

With a range of sizes and power ratings to suit any application, Convector provides the capacity, control and power you need.

Ideally suited for...

A modern, smart design that looks great both front of house and in the kitchen, with a range of sizes and power ratings to suit any application. Places such as:



Bakeries

Whether you're starting from scratch, or from par-baked or pre-proved products, produce uniform results, even when full, so all of your bakes look the same every time.



Restaurants

Convector is a great choice for roasting and braising, with two speed fan perfect for switching to slow speed, to tenderise meat at the end of the cooking cycle.



Pubs

The Convector range is able to roast, braise, bake and reheat. Ideal for when you need consistently even results from a fully loaded oven.

Benefits at a glance

- Uniform results, every time, even when full
- Two-speed bi-directional fan
- Oven cavity optimised for airflow
- Flashing oven lamps when cook cycle ends
- Roast, braise, bake and reheat
- Manual+ and Touch models available
- Intuitive easy to use controls

Putting you in control for perfect results every time

Convect convection ovens put you in control. They give you the power to produce perfect results every time, with two control panel options, **Manual+** and **Touch**.



Manual+ provides the best of both worlds, the simplicity of mechanical temperature control and the cooking benefits afforded by two-speed electronic fan control.

Even in the busiest, noisiest kitchen the Convector's electronically controlled buzzer and flashing oven lamps will ensure that you hear and see that it has reached the end of its cooking cycle.

Touch control's 4.3" touchscreen menu is intuitive and provides the wider functionality and greater control that only a touchscreen can deliver. Cook programs are easy to set up and simple to use. Up to four stages can be created with an icon assigned to each of the 24 programs.



MANUAL+ CONTROL

Easy-to-use knob-driven control, mechanical temperature control, electronic fan control.



TEMPERATURE CONTROL

Mechanical thermostat 60°C to 260°C.

COUNT DOWN TIMER

120-minute timer with electronically-controlled buzzer. Oven lamps flash when the cook cycle has finished until the door is opened.

EVEN HEAT DISTRIBUTION

Electronically controlled two-speed, bi-directional fan.

TWO FAN SPEEDS

Standard for general use and slow for delicate items such as meringue, choux pastry, flans and quiches.

TOUCH CONTROL

Touchscreen control with easy-to-use icon-driven menu selections.



ColourCue
● ● ●

EASY-VIEW TRAFFIC LIGHT STATUS

Great for busy and noisy kitchens, ColourCue shows you the status of the oven at a glance: red - action is required such as unload; amber - the oven is pre heating or cooking; green - the oven is ready.

PHASED COOKING

Four-stage cooking for perfect results - set temperature, time, fan speed and humidity injection for each stage.

PROGRAM MODE

24 programs with up to four stages, which you can adjust individually. Icons and names can be assigned to each program to make it even easier to use, especially for untrained staff.

MANUAL MODE

Simple and easy to set the time and temperature required, then manually control humidity injection and fan speed during the cook cycle.

SHELF TIMER MODE

Four individual nine-hour timers allow you to track different products in program and manual mode.

TEMPERATURE CONTROL

Precise electronic temperature control from 30°C to 260°C.

COUNT DOWN TIMER

Nine-hour on-screen timer. An electronic buzzer sounds and the oven lamps flash when the cook cycle has finished until the door is opened or the alert is cancelled on the touchscreen.

HUMIDITY LEVELS

Five levels of humidity injection on C0100 and C0200 models

EVEN HEAT DISTRIBUTION

Electronically controlled two-speed, bi-directional fan.

TWO FAN SPEEDS

Standard for general use and slow for delicate items such as meringue or choux pastry.

USB

USB port for copying programs, ideal for operations with multiple sites. Future updates can also be easily managed.

The Range

We offer a range of convection ovens to suit any application and provide the capacity, control and power you need.



Model	C0133M	C0133T	C0223M	C0223T
List Price	£2579 / €2966	£3415 / €3927	£2855 / €3284	£3789 / €4357
GN Capacity	3 x GN2/3	3 x GN2/3	2 x GN1/1	2 x GN1/1
Sheet Capacity	400 x 300 Baking Sheets 460 x 330 Baking Sheets	400 x 300 Baking Sheets 460 x 330 Baking Sheets	600 x 400 Baking Sheets 660 x 460 Baking Sheets	600 x 400 Baking Sheets 660 x 460 Baking Sheets
Capacity Litres	53	53	96	96
Height (External) mm	645	645	645	645
Width (External) mm	610	610	810	810
Depth (External) mm	750	750	850	850
Height (Internal) mm	308	308	308	308
Width (Internal) mm	490	490	690	690
Depth (Internal) mm	370	370	470	470
Oven Rating kW	2.8	2.8	2.8	2.8
Weight kg	71	72	91	92

Accessories

	C0100/FS	C0100/FS	C0200/FS	C0200/FS
Floor stand 6 runners	C0100/FS	C0100/FS	C0200/FS	C0200/FS
List Price	£1087 / €1251	£1087 / €1251	£1087 / €1251	£1087 / €1251
Low floor stand and stacking kit	C0100/LFSK	C0100/LFSK	C0200/LFSK	C0200/LFSK
List Price	£1087 / €1251	£1087 / €1251	£1087 / €1251	£1087 / €1251

Water Treatment Units

It is recommended that a water treatment unit is installed with all Convector Touch models.

A water treatment unit will filter chemicals from the incoming water, including calcium helping to prevent the build up of limescale within the unit and ensuring steam is generated from purified water.

MODEL	PRICE £	PRICE €	DESCRIPTION
A ACIK04	£312	€360	Filter Kit
C FC23	£159.90	€183.90	Filter Cartridge





CO235M	CO235T	CO343M	CO343T
£3041 / €3498	£3973 / €4569	£2606 / €2997	£2911 / €3349
3 x GN1/1	3 x GN1/1	4 x GN1/1	4 x GN1/1
600 x 400 Baking Sheets 660 x 460 Baking Sheets	600 x 400 Baking Sheets 660 x 460 Baking Sheets	400 x 300 Baking Sheets 460 x 330 Baking Sheets	400 x 300 Baking Sheets 460 x 330 Baking Sheets
96	96	72	72
645	645	600	600
810	810	660	660
850	850	740	740
308	308	398	398
690	690	330	330
470	470	550	550
4.6	4.6	2.8	2.8
93	94	84	84

CO200/FS	CO200/FS	CO300/FS	CO300/FS
£1087 / €1251	£1087 / €1251	£1087 / €1251	£1087 / €1251
CO200/LFSK	CO200/LFSK	CO300/LFSK	CO300/LFSK
£1087 / €1251	£1087 / €1251	£1087 / €1251	£1087 / €1251



2 YEAR
UK parts and labour warranty
Export parts warranty
on all Lincat products

* Please refer to pages L117 to L118 for electricity supply requirements

Technical Details and Accessories

Convector convection ovens have a modern, smart design that looks great both front of house and in the kitchen. However, it is the detail which makes all the difference, together with ease of use and the quality and consistency of the food it can produce.

1 OPTIMISED OVEN CAVITY

The optimised geometry of the oven cavity and side deflectors ensure that airflow is optimised across the shelves.

2 TWO SPEED, BI-DIRECTIONAL FAN SYSTEM

The powerful 190mm diameter bi-directional stainless-steel fan ensures that heat is distributed evenly throughout the cabinet, to deliver consistent results even with full loads. The standard fan speed is ideal for general use, the slow for delicate items such as meringue, choux pastry, flans and quiches.

3 DOUBLE GLASS DOOR

Double glass doors ensure that the outer door stays cool and is safe to touch. The inner glass is easily removable for cleaning, so you can always have a clear view of what's cooking.

4 OVEN CONSTRUCTION

100% stainless steel construction. The oven cabinets of Touch models, which are equipped with five levels of humidity injection, are constructed from 304-grade stainless steel for durability.

5 OVEN CABINET SEAL

The new plug-in continuous door seal is robust and seamless, which makes cleaning and replacement quick and easy without the need for tools.

6 RACKING SYSTEM

Oven racks are anti-tilt. Easy-to-release screws allow the side racks to be removed quickly for cleaning.

7 TRAY SPACING

Optimised tray spacing provides the flexibility required to use baking sheets or gastronorm dishes.

8 HALOGEN LAMPS

Offset lamp heights and energy efficient, brighter white light dual halogen lamps provide optimum illumination for both the cabinet and each individual shelf. Perfect for busy, noisy kitchens, the halogen lamps flash when the cook cycle has finished and continue to do so until the door is opened.

9 COMPACT FOOTPRINT

The Convector series has been designed to take up the minimum of counter or floor space, whilst still taking standard sizes of gastronorm dishes and euro baking sheets.

10 STACKING KIT

In kitchens where space is at a premium, two Convector ovens can be stacked, one on top of the other, using a stacking kit. This not only increases output potential but also provides the flexibility to cook products which require different temperatures, times or humidity.

11 STANDS

Stands are made from high-quality, stainless steel and provide robust, secure support for your Convector oven.

12 NON-SLIP FEET

Non-slip feet not only ensure that the oven stays in position and resists movement, but also reduce noise and vibration during operation.



Lincat CombiSlim

lincat.co.uk

Lincat

Combi Ovens

L29

2026

Lincat CombiSlim



The optimal choice when size matters.

In partnership with our sister company, the Scandinavian Combi Specialist Hounö, we are delighted to offer the popular **CombiSlim** ovens to the UK market under the Lincat brand.

Measuring just 513mm wide and accommodating a full size 1/1 gastronorm, the **CombiSlim** ovens are perfect for front of house and compact kitchens where space is limited but high output and consistent results are needed or for satellite kitchens in combination with our Invoq ovens.

Ease of use is at the heart of **CombiSlim** ovens, they're controlled using Android-based **SmartTouch**®, an intuitive touch control display, and feature **SmartChef**® pre-set recipes, making operation simple and seamless for kitchen staff of all levels.

CombiSlim ovens feature steam injection, with **CombiSmart**® humidity control, the ability to create cooking programmes with up to 15 steps, and a rack timer that ensures accurate cooking for different items on different shelves.

After service, **CombiWash**®, the automatic cleaning system saves on staff time and operating costs, through low consumption of energy, water, and detergent.

CombiSlim ovens are available in 2 sizes, 6 grid and 10 grid and accommodate 1/1 GN trays. For maximum flexibility, stack 2 **CombiSlim** ovens.

With the optional **Hoodini** ventless hood, place your CombiSlim virtually anywhere and remove grease, vapours, and contaminants from the air.

Ideally suited for...

CombiSlim ovens are small but effective, providing the same features as a large combi oven giving you maximum flexibility.



Cafés & Coffee Shops

Expand your menu options with perfectly cooked dishes and bakes.



Forecourts & Convenience Stores

Invest in a **CombiSlim** to expand your range and increase sales.



Hospitals

Support nutritious meal preparation for patients and staff for overall wellbeing.



Hotels

When used in combination with our Invoq ovens in the central kitchen, **CombiSlim** ovens are perfect for finishing in smaller satellite kitchen areas.

Lincat CombiSlim

CombiSlim
provides maximum
flexibility in
minimum space.

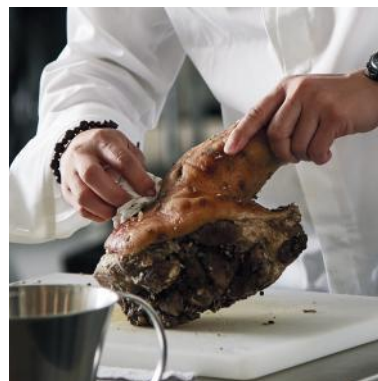

Benefits at a glance

- 513mm wide footprint
- Accommodates 6 or 10 1/1GN trays
- Consistent regardless of the operator
- Steam injection
- **SmartChef**® pre-set recipes
- Easy to use **SmartTouch**®, intuitive touch control display
- **CombiSmart**® 10 steps, humidity control
- Temperature Probe
- HACCP monitoring
- Available with a **Hoodini** ventless hood (see page L59 for more information)



**Please call us to
arrange to see
CombiSlim live
and in action!**

+44 (0) 1522 875500

Lincat CombiSlim



CombiSlim

- Measuring just 513mm wide and accommodating a full size 1/1 gastronorm
- CombiSlim ovens are small but effective, providing the same features as a large combi oven giving you maximum flexibility
- All ovens are 50 herts, 3 Phase



MODEL	LCS106	LCS110
Price	£9730/€11,677	£12,086/€14,504
Height (mm)	753	948
Width (mm)	513	513
Depth (mm)	811	811
Power (kW)	8.4	12.7
Capacity (in gastronorms)	6 x GN1/1	10 x GN1/1
No. of meals per day	60	30-80
Weight (kg)	67	81

Standard Features

- Electric
- Injection steam
- **SmartTouch**[®] display
- 2-piece rack
- Temperature probe
- PROTECT start kit
- Chef's recipe collection
- Baker's recipe collection
- Favourites selection
- HACCP quality control, 60 days in PDF format

CombiSlim with Hoodini

- See page L59 for more information on **Hoodini**
- Invest in a combi oven without the cost and installation of a commercial hood system
- Utilise non-traditional spaces
- Ideal for where venting to the atmosphere is impractical or not possible
- Hoodini uses less energy over traditional hood system, a great way to work towards being carbon neutral



MODEL	LCSH106	LCSH110
Price	£14,335/€17,202	£16,691/€20,029
Height (mm)	1138	1338
Width (mm)	514	514
Depth (mm)	1041	1041
Power (kW)	8.4 + 2.2	12.7 + 2.2
Capacity (in gastronorms)	6 x GN1/1	10 x GN1/1
No. of meals per day	60	30-80
Weight (kg)	110	115

Cooking Modes

- Hot air (Convection)
- Steaming
- Low-temperature steaming
- Forced steaming
- **CombiSmart**[®], 10 steps humidity control
- Cook & Regeneration
- Proving, with automatic humidification
- Preheating
- Automatic cooling function
- Manual humidity pulsing
- Reversing, adjustable fan with 9 speeds
- **SmartChef**[®], automatic cooking
- Automatic humidity pulsing
- **RackTimer**[®], with up to 20 timers
- Cool down function
- Delta-T
- Cook & Hold

* Please refer to pages L117 to L118 for electricity supply requirements

CombiSlim - Accessories, Options and Consumables

Oven Stands

MODEL	PRICE £	PRICE €	DESCRIPTION	FOR MODELS	
				LCS611 & LCSH611	LCS1011 & LCSH1011
A LCSO1	£740	€888	Static Open Stand	•	•
A LCSR1	£803	€964	Static Stand with Runners	•	•

Stacking Kit

MODEL	PRICE £	PRICE €	DESCRIPTION	FOR MODELS	
				LCS611 & LCSH611	LCS1011 & LCSH1011
A 32020054	£1060	€1273	Stacking Kit 1.06 + 1.06 and Low Floor Stand	•	•
A 107971	£366	€439	Castors for low floor stand	•	•

Extraction Hoods

MODEL	PRICE £	PRICE €	DESCRIPTION	FOR MODELS	
				LCS611 & LCSH611	LCS1011 & LCSH1011
A 32620112	£2027	€2433	Condensation Hood	• (only LCS611)	• (only LCS1011)

Water Treatment

MODEL	PRICE £	PRICE €	DESCRIPTION	FOR MODELS	
				LCS611 & LCSH611	LCS1011 & LCSH1011
C 30500546	£846	€1016	Hydro Shield 6000 (XL) Water Filter Cartridge	•	•
S 108139	£1257	€1508	Hydro Shield 6000 (XL) Water Filter Kit - inc. Filter, Filter Head and Hose	•	•

Detergent

MODEL	PRICE £	PRICE €	DESCRIPTION	FOR MODELS	
				LCS611 & LCSH611	LCS1011 & LCSH1011
C 30500571	£160	€193	HOUNÖ PROTECT Detergent Intense 2 x 5 Litre	•	•
C 20500200	£160	€193	HOUNÖ PROTECT Rinse aid 2 x 5 Litre	•	•
C 30520494	£552	€663	HOUNÖ PROTECT cleaning package (6 x Intense + 2 x Rinse)	•	•

Grills, Trays and Sheets

MODEL	PRICE £	PRICE €	DESCRIPTION	FOR MODELS	
				LCS611 & LCSH611	LCS1011 & LCSH1011
A 45482	£149	€180	Imperial Tray, 1/1 GN, 20mm	•	•
A 45484	£154	€185	Imperial Tray, 1/1 GN, 40mm	•	•
A 45483	£175	€210	Imperial Tray, 1/1 GN, 60mm	•	•
A 45723	£196	€235	Imperial Sheet, 1/1 GN	•	•
A 45481	£175	€210	Imperial Grilling Grid, 1/1 GN	•	•
A 113151	£101	€121	Baking Tray Non-Stick, 1/1 GN	•	•
A 113152	£117	€140	Baking Tray Perforated Non-Stick, 1/1 GN	•	•
A 45445	£96	€115	Baking Mat Silicone, 1/1 GN	•	•
A 45725	£128	€153	Imperial Multi-Tray, 1/1 GN	•	•
A 45480	£128	€153	Steamfry Basket, 1/1 GN	•	•
A 45733	£138	€166	Rib Rack, 1/1 GN	•	•
A 41120	£64	€77	Chicken Grill, 1/2 GN - for 4 pcs.	•	•
A 33089	£128	€153	Chicken Grill, 1/1 GN - for 8 pcs.	•	•
A 45722	£149	€179	Imperial Potato Spikes, 1/1 GN	•	•
A 45081	£56	€66	Grill, stainless steel, 1/1 GN	•	•





Lincat InvoQ



Invoq

Introducing an intuitive oven platform for baking, cooking and steaming that's as simple as it looks.

Designed by our sister company, the Scandinavian Combi Specialist Hounö, the new Lincat Invoq may look simple, but is in fact one of the most advanced and capable ovens ever made.

Created as a collaborative exercise with six global food service brands, including Lincat, means that Invoq became an oven that could be configured to suit any setting, restaurant or serving situation anywhere in the world.

The Invoq range



Invoq | Combi

Featuring **CombiSteam**, injection steam for full steaming capacity that is fast, efficient, and safe.

Invoq | Hybrid

Featuring **HybridSteam**, a combination of an energy efficient boiler with an injection steam system. The oven delivers fast, efficient, and safe high-density steam saturation – perfect for intensive steaming production.

Invoq | Bake

With the Invoq Bake you get an even and consistent bake covering all aspects of the baking from beautifully crusty breads to perfectly baked products from frozen and even delicately baked desserts.



Invoq

Combi Ovens

ClimateControl

Invoq includes key design elements to deliver optimised air distribution and airflow, improved humidity accuracy and faster moisture evacuation.

Fine-tuned humidity

On top of **CombiSteam** and **HybridSteam**, Invoq comes with two additional features for fine tuning humidity; **CombiSense** on all Invoq models including Bake and **CombiSpeed** on the Invoq Combi and Hybrid.



Smartphone simple oven operation

Invoq is '**smartphone simple**', allowing extremely advanced, sophisticated, and sometimes unprecedented technology to be accessed, enjoyed and controlled with ease - by anyone.

The Invoq Combi and Hybrid feature **SmartChef**, while the Invoq Bake offers **SmartBaker**. These intelligent cooking functionalities guide you effortlessly to a great result.

With **MenuPlanner** and **TablePlanner** integrated into Invoq Combi and Hybrid, users can effectively manage multiple dishes, tracking each item's progress on different racks and adjusting cooking times for synchronized finishing.

Invoq Bake's Quick Select Recipes (**QSR**) empower all team members, regardless of experience level, to consistently produce high-quality baked goods. **QSR** streamlines operations, saving time and reducing the likelihood of errors.

Lincat

lincat.co.uk

Invoq

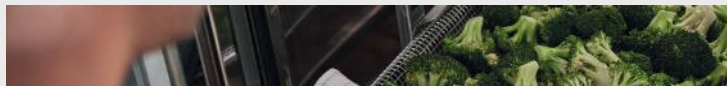

Increased capacity

Invoq Combi and Hybrid models, with an additional tray in 6-grid ovens, provide 17% more capacity, while Invoq Bake offers 20% more capacity with an extra tray.



Move towards a more Sustainable Kitchen

Without even making any changes to your usage pattern but simply by replacing your oven, Invoq can save you energy, lower your bills and reduce your carbon footprint.

A connected kitchen

Invoq ovens are supplied with a WIFI module as standard and are designed to work with the Open Kitchen app. Remotely update software, upload and distribute new recipes, oversee your energy consumption or running costs, monitor your service schedule or access your HACCP data.

Stay spotless

CareCycle is the automatic cleaning system built into Invoq that saves both time and money.

CareCycle uses surprisingly little water, energy or chemicals and it ensures your oven is always spotlessly clean and ready for the next task.



Learn more and discover the Invoq that is precisely right for you.

Invoq Combi and Invoq Hybrid, pages L44-L48
Invoq Bake, pages L49-55



Invoq

Combi Ovens

Ideally suited for...

Invoq is a single solution tailored to meet the needs of different market segments. From restaurants to institutional kitchens and supermarkets. It has been designed from the point of view of chefs, kitchen designers and consultants. All of those who have a say in creating a commercial kitchen.



Quick Serve Restaurants

Use **SmartChef** to cook all food in the same way, regardless of which restaurant you visit, to experience the same quality and uniform results all the time.



Hospitals

HybridSteam, this high-density steam saturation, designed for intensive steaming production, offers full flexibility and endless possibilities.



Education

Roll-in combi ovens: The perfect solution for high volume cooking. Discover the roll-in combi oven: streamline high-volume cooking, reduce labour costs, and boost productivity.



Forecourts and Convenience Stores

By stacking two units, it becomes possible to simultaneously cook different batches of products, all while saving valuable floor space. The inclusion of hoods streamlines the installation process, making it both effortless and adaptable.

Benefits at a glance

- Invoq Combi and Hybrid with an extra tray in 6 grid ovens, delivers 17% more capacity
- Invoq Bake with an extra tray, delivers 20% more capacity
- Less energy usage
- **SmartPhone** simple to use
- Automatic, intelligent cooking regardless of operator or skill level
- **ClimateControl**, perfectly controlled for optimum quality
- Innovative steam generation technologies
- Fine tune for humidity levels
- **CareCycle** automatic cleaning system
- All ovens are supplied with a WIFI module as standard
- Open Kitchen compatible



Please call us to arrange to see Invoq live and in action!

+44 (0) 1522 875500



Lincat

lincat.co.uk

2026

Invoq



With Invoq, we have two innovative steam generation technologies, **CombiSteam** and **HybridSteam** to suit different settings.

CombiSteam.

A powerful injection of steam. Right now.

Instead of waiting for water to boil, **CombiSteam** injects water directly through the oven's heating elements. So, in seconds, with a minimum of energy, the entire Invoq oven becomes a steam chamber. No waiting. No water tank **CombiSteam** is featured on all Invoq Combi models.

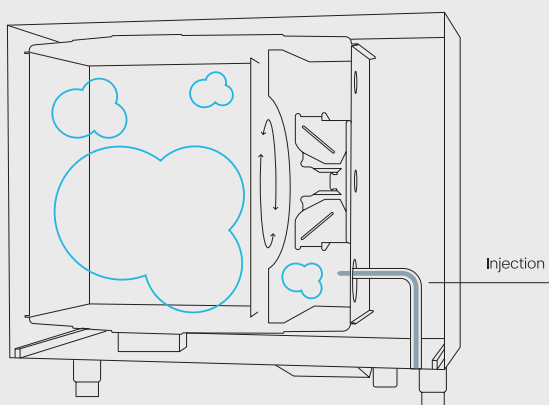

CombiSteam is designed for:

- Retail
- QSR
- Restaurants
- Bakeries

HybridSteam.

Steam that can be both subtle and powerful.

In circumstances where either the food or the setting is less dictated by speed, HybridSteam is a unique method of creating humidity. On top of **CombiSteam**, a water reservoir - located within the oven casing - has been added, to provide the oven with an additional way to generate high-density steam saturation.

Depending on what you are cooking, intelligent sensors instruct the Invoq oven to deploy either injected steam or steam created from water in the boiler - or both, in tandem or sequence. This choice of interventions allows a spectrum of possibilities because steam can be added with finer and more comprehensive control.

HybridSteam is exclusively featured on the Invoq Hybrid models.

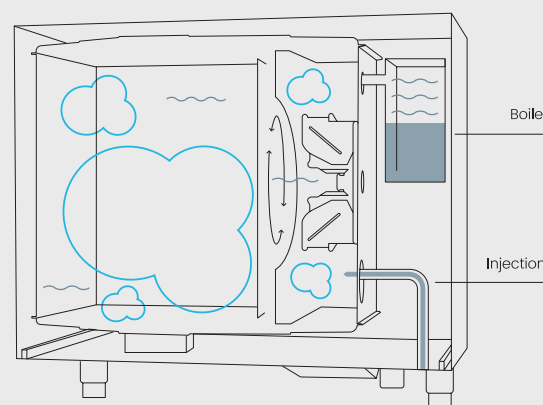

HybridSteam is designed for:

- Canteens
- Hospitals
- Education
- Central kitchens

Invoq



Invoq technology offers additional ways to fine-tune humidity.

On top of **CombiSteam** and **HybridSteam**, Invoq comes with two additional features that allow you to produce predictably accurate results using the power of humidity.

CombiSense. Deliciousness inside and out.

CombiSense is an automatic humidity system that allows you to cook at high temperatures without drying out food or degrading its flavour or colour. It is ideal when you need to cook something that needs to be crisp on the outside and naturally moist on the inside. To produce the desired 'Maillard Reaction', Invoq has sensors that supervise and control the entire cooking cycle. They continuously adjust humidity levels on a percentage basis depending on the moisture released by the food, regardless of how full the oven is or whether you're cooking from cold or frozen.

CombiSpeed. Cook faster and improve yield.

By injecting humidity, **CombiSpeed** both accelerates cooking times and locks in moisture and tenderness, so you get less shrinkage and more portions per serving. When used at low temperatures overnight, it keeps food succulent and juicy. Ten **CombiSpeed** settings allow you to choose the optimal level for your specific menu or workflow.



Steam roasting
Grilling
Pan frying
Convenience
Bake-off



Braising
Roasting
Low-temperature cooking
Overnight cooking
Holding
Sous vide

Invoq



An oven controlled by a tablet.



SmartChef. Change from manual to automatic.

SmartChef is an automatic feature for intelligent cooking. Select the type of food, desired cooking method and core temperature. Press start and the oven will guide you step by step through the process for a perfect result. Save your favourites and edit, if needed.



MenuPlanner. Make all users successful.

MenuPlanner allows you to drag and drop your servings for an all-day service. You can easily keep track of all racks and adjust items to be finalised simultaneously, if preferred. You can even set up to three products on the same rack and the oven automatically compensates temperature changes with **CookTimeCorrection (CTC)**. Smooth and stressless operation.

TablePlanner. 3 racks in 1.

The **TablePlanner** function allows you to combine up to three different products with one timer. Simply select your menu items; the oven will tell you when to load which item, and they will be ready for service at the same time.



ClimateControl. Be in charge of the environment in your oven.

ClimateControl ensures optimised processes and shorter cooking times. Key design elements produce optimised air distribution and airflow, improved humidity accuracy and faster moisture evacuation. Everything is perfectly controlled for optimum quality.



CareCycle. Customise the way you keep spotless.

Although a clean oven is a necessity, cleaning can interrupt service or make your workflow more complex. **CareCycle** is a phosphate free tablet-based way to clean, with seven programs ranging from Eco to Turbo. It produces excellent results with surprisingly little water or chemicals, and you can program **CareCycle** to get to work at your convenience.



Invoq

Combi Ovens

Invoq helps you move towards a more sustainable kitchen.

Convection 

19% less energy used per running hour

Technology behind the scenes:

- Triple layer glass door
- Improved airflow contributing to the Maillard reaction
- Improved air intake - three times faster dehumidification
- Energy-efficient insulation

Steam 

70% less energy used per running hour

Technology behind the scenes:

- Improved steam saturation based on lambda sensor
- Improved boiler performance (%)
- **HybridSteam** implementation
- Closed drain system

Cleaning 

70.7% less costs
27% less water
63% less time

Technology behind the scenes:

- Recirculating cleaning system
- Less and greener chemicals
- Cleaning programs to match your needs

Your savings 

Cost savings of £1,401/€1,612 per year

User scenario based on following operation:

- Eight hours a day (six hours convection, two hours steaming, one medium cleaning)
- Five days a week
- 48 weeks a year

Based on a kWh price of € 0.46 and a water price of € 1.45 per m3. Comparison: Invoq Hybrid 10-1/1 GN up against predecessor model.

Lincat

lincat.co.uk

2026

Invoq | Combi



Invoq Combi

- Featuring **CombiSteam**, please see page L40 for more information
- All ovens are 50 Hertz, 3 phase



MODEL	LQC106	LQC110	LQC120	LQC206	LQC210	LQC220
Price	£9498/€11,398	£13,124/€15,749	£20,958/€25,149	£15,949/€19,139	£20,872/€25,045	£36,186/€43,423
Height (mm)	851	1081	1730	851	1081	1730
Width (mm)	937	937	937	1077	1077	1077
Depth (mm)	908	908	923	1028	1028	1043
Power (kW)	10.3	19.3	38.2	22.3	31.3	62.2
Capacity (in gastronorms)	6 x GN1/1	10 x GN1/1	20 x GN1/1	6 x GN2/1	10 x GN2/1	20 x GN2/1
No. of meals per day	90	150	300	180	300	600
Weight (kg)	127	159	276	150	181	327

Invoq Combi PassThrough

- Please see page L56 for more information on **PassThrough**
- Featuring **CombiSteam**, please see page L40 for more information
- All ovens are 50 Hertz, 3 phase



MODEL	LQC106PT	LQC110PT
Price	£12,528/€15,035	£18,500/€22,200
Height (mm)	851	1081
Width (mm)	937	937
Depth (mm)	1059	1059
Power (kW)	10.3	19.3
Capacity (in gastronorms)	6 x GN1/1	10 x GN1/1
No. of meals per day	90	150
Weight (kg)	149	184



Invoq | Hybrid

Invoq Hybrid

- Featuring **HybridSteam**, please see page L40 for more information
- All ovens are 50 Hertz, 3 phase



MODEL	LQH106	LQH110	LQH120	LQH206	LQH210	LQH220
Price	£13,587/€16,304	£13,821/€16,585	£22,872/€27,447	£16,779/€20,136	£21,975/€26,371	£37,503/€45,004
Height (mm)	851	1081	1730	851	1081	1730
Width (mm)	937	937	937	1077	1077	1077
Depth (mm)	908	908	923	1028	1028	1043
Power (kW)	10.3	19.3	38.2	22.3	31.3	62.2
Capacity (in gastronorms)	6 x GN1/1	10 x GN1/1	20 x GN1/1	6 x GN2/1	10 x GN2/1	20 x GN2/1
No. of meals per day	90	150	300	180	300	600
Weight (kg)	136	159	288	158	189	342

Invoq Hybrid PassThrough

- Please see page L56 for more information on **PassThrough**
- Featuring **HybridSteam**, please see page L40 for more information
- All ovens are 50 Hertz, 3 phase



MODEL	LQH106PT	LQH110PT
Price	£13,587/€16,304	£19,536/€23,238
Height (mm)	851	1081
Width (mm)	937	937
Depth (mm)	1059	1059
Power (kW)	10.3	19.3
Capacity (in gastronorms)	6 x GN1/1	10 x GN1/1
No. of meals per day	90	150
Weight (kg)	157	192



Invoq Combi / Hybrid - Accessories, Options and Consumables

Oven Stands

FOR MODELS

MODEL	PRICE £	PRICE €	DESCRIPTION	LQC106	LQC110	LQC120	LQC206	LQC210	LQC220	LQH106	LQH110	LQH120	LQH206	LQH210	LQH220	LQC106PT	LQC110PT	LQH106PT	LQH110PT
A LQSO1	£548	€658	Static Open Stand	•	•					•	•					•	•	•	•
A LQSR1	£1217	€1461	Static Stand with Runners and Chemical Drawer	•	•					•	•					•	•	•	•
A LQCK	£366	€440	Castor Kit for LQSO1 and LQSR1 - 2 x Braked, 2 x Unbraked	•	•					•	•					•	•	•	•
A 106170	£828	€951	Static Open Stand				•	•					•	•					

Trolley System

FOR MODELS

MODEL	PRICE £	PRICE €	DESCRIPTION	LQC106	LQC110	LQC120	LQC206	LQC210	LQC220	LQH106	LQH110	LQH120	LQH206	LQH210	LQH220	LQC106PT	LQC110PT	LQH106PT	LQH110PT
A 107592	£1997	€2398	Roll-in Trolley 20-1/1 GN 65 mm 20 trays U-shaped			•						•							
A 108140	£1997	€2398	Roll-in Trolley 20-1/1 GN 85 mm 15 trays U-shaped			•						•							
A 107876	£2485	€2982	Roll-in Trolley 20-2/1 GN 65 mm 20 trays U-shaped						•						•				
A 107101	£2485	€2982	Roll-in Trolley 20-2/1 GN 85 mm 15 trays U-shaped			•			•						•				
A 108142	£2196	€2635	Banqueting Roll-in Trolley 20-1/1 GN (50 plates)									•							
A 108143	£4180	€5017	Banqueting Roll-in Trolley 20-2/1 GN (100 plates)			•			•						•				
A 108149	£1304	€1565	Thermo Cover (1/1 GN)									•							
A 045462	£1774	€2128	Thermo Cover (2/1 GN)						•						•				

Stacking Kit

SEE PAGE L57 FOR MORE INFORMATION

FOR MODELS

MODEL	PRICE £	PRICE €	DESCRIPTION	LQC106	LQC110	LQC120	LQC206	LQC210	LQC220	LQH106	LQH110	LQH120	LQH206	LQH210	LQH220	LQC106PT	LQC110PT	LQH106PT	LQH110PT
A 107800/965	£1283	€1539	Stackit 1/1 GN, electric + Low Floor Stand	•						•									
A 107803/966	£1606	€1926	Stackit 2/1 GN, electric + Low Floor Stand				•						•						
A 111725/965	£1283	€1539	Stackit 1/1 GN, PassThrough, electric + Low Floor Stand													•		•	
A 107971	£366	€439	Castors for low floor stand	•			•			•			•			•		•	

Drain Lift Solution

SEE PAGE L60 FOR MORE INFORMATION

FOR MODELS

MODEL	PRICE £	PRICE €	DESCRIPTION	LQC106	LQC110	LQC120	LQC206	LQC210	LQC220	LQH106	LQH110	LQH120	LQH206	LQH210	LQH220	LQC106PT	LQC110PT	LQH106PT	LQH110PT
A 110891	£722	€867	Drain Lift System, single oven, upgrade kit	•	•	*	•	•	*	•	•	*	•	•	*	•	•	•	•
A 110892	£722	€867	Drain Lift System, stacked oven, upgrade kit	•	•	•	•	•	•	•	•	•	•	•	•	•	•	•	•

*factory fitted option only



Invoq Combi / Hybrid - Accessories, Options and Consumables

Extraction Hoods

SEE PAGE L58 - L59 FOR MORE INFORMATION

FOR MODELS

MODEL	PRICE £	PRICE €	DESCRIPTION	LQC106	LQC110	LQC120	LQC206	LQC210	LQC220	LQH106	LQH110	LQH120	LQH206	LQH210	LQH220	LQC106PT	LQC110PT	LQH106PT	LQH110PT
A 110907	£4263	€5116	Condensation Hood 1/1 GN, Upgrade Kit	•	•					•	•								
A 110906	£4263	€5116	Condensation Hood 1/1 GN, PassThrough, Upgrade Kit													•	•	•	•
A 110903	£4770	€5724	Condensation Hood 1/1 GN, 20-1 Roll-In, Upgrade Kit			•						•							
A 110905	£4770	€5724	Condensation Hood Stackit 1/1 GN, Upgrade Kit	•	•					•	•								
A 110904	£4770	€5724	Condensation Hood Stackit 1/1 GN, PassThrough, Upgrade Kit													•	•	•	•
A 110924	£5256	€6307	Condensation Hood 2/1 GN, Upgrade Kit				•	•					•	•					
A 110922	£6000	€7200	Condensation Hood 2/1 GN, 20-2 Roll-In, Upgrade Kit						•						•				
A 110928	£6000	€7200	Condensation Hood Stackit 2/1 GN, Upgrade Kit				•	•					•	•					
A 111458	£7035	€8442	Hoodini Hood 1/1,GN, single units, Upgrade Kit	•	•	•				•	•	•							
A 111457	£7412	€8894	Hoodini Hood 1/1,GN, single units, PassThrough, Upgrade Kit													•	•	•	•
A 111456	£10,742	€12,891	Hoodini Hood 1/1 GN, stacked units, Upgrade Kit	•	•					•	•								
A 111455	£11,114	€13,337	Hoodini Hood 1/1 GN, stacked units, PassThrough, Upgrade Kit													•	•	•	•
A 111472	£7601	€9122	Hoodini Hood 2/1,GN, single units, Upgrade Kit				•	•					•	•					
A 111474	£11,657	€13,988	Hoodini Hood 2/1 GN, stacked units, Upgrade Kit				•	•					•	•					

Heat Shields

FOR MODELS

MODEL	PRICE £	PRICE €	DESCRIPTION	LQC106	LQC110	LQC120	LQC206	LQC210	LQC220	LQH106	LQH110	LQH120	LQH206	LQH210	LQH220	LQC106PT	LQC110PT	LQH106PT	LQH110PT
A 108120	£330	€396	Heat shield 6-1/1 GN	•						•						•		•	
A 108121	£359	€431	Heat shield 10-1/1 GN		•						•							•	•
A 108122	£369	€443	Heat shield 6-2/1 GN				•						•						
A 108123	£409	€491	Heat shield 10-2/1 GN					•						•					
A 108124	£440	€528	Heat shield 20-1/1 GN			•						•							
A 108125	£531	€638	Heat shield 20-2/1 GN						•						•				

Fat Separation

FOR MODELS

MODEL	PRICE £	PRICE €	DESCRIPTION	LQC106	LQC110	LQC120	LQC206	LQC210	LQC220	LQH106	LQH110	LQH120	LQH206	LQH210	LQH220	LQC106PT	LQC110PT	LQH106PT	LQH110PT
O 104853	£1194	€1414	Fat Separation System Invoq Combi 1/1 models - Factory Fitted	•	•	•				•	•	•				•	•	•	•
O 104841	£1471	€1767	Fat Separation System Invoq Combi 2/1 models - Factory Fitted				•	•	•				•	•	•				

Water Treatment

FOR MODELS

MODEL	PRICE £	PRICE €	DESCRIPTION	LQC106	LQC110	LQC120	LQC206	LQC210	LQC220	LQH106	LQH110	LQH120	LQH206	LQH210	LQH220	LQC106PT	LQC110PT	LQH106PT	LQH110PT
C 30500546	£846	€1016	Hydro Shield 6000 (XL) Water Filter Cartridge	•	•	•	•	•	•	•	•	•	•	•	•	•	•	•	•
S 108139	£1257	€1508	Hydro Shield 6000 (XL) Water Filter Kit - inc. Filter, Filter Head and Hose	•	•	•	•	•	•	•	•	•	•	•	•	•	•	•	•



Invoq Combi / Hybrid - Accessories, Options and Consumables

Detergent

FOR MODELS

MODEL	PRICE £	PRICE €	DESCRIPTION	LQC106	LQC110	LQC120	LQC206	LQC210	LQC220	LQH106	LQH110	LQH120	LQH206	LQH210	LQH220	LQC106PT	LQC110PT	LQH106PT	LQH110PT
C 106032	£200	€241	CareCycle Clean tablets - 150	*	*	*	*	*	*	*	*	*	*	*	*	*	*	*	*
C 106033	£200	€241	CareCycle Descale tablets - 150	*	*	*	*	*	*	*	*	*	*	*	*	*	*	*	*
A 110247	£371	€427	Hand Shower	*	*	*	*	*	*	*	*	*	*	*	*	*	*	*	*

Grills, Trays and Sheets

† SEE PAGE L61 FOR MORE INFORMATION

FOR MODELS

MODEL	PRICE £	PRICE €	DESCRIPTION	LQC106	LQC110	LQC120	LQC206	LQC210	LQC220	LQH106	LQH110	LQH120	LQH206	LQH210	LQH220	LQC106PT	LQC110PT	LQH106PT	LQH110PT
A 107840	£597	€717	MultiRack 6-1/1 GN and 400 x 600 †	*			*			*			*			*		*	
A 107846	£707	€848	MultiRack 10-1/1 GN and 400 x 600 †		*	*		*	*		*	*		*	*		*		*
A 45482	£149	€179	Imperial Tray, 1/1 GN, 20mm	*	*	*	*	*	*	*	*	*	*	*	*	*	*	*	*
A 45484	£154	€185	Imperial Tray, 1/1 GN, 40mm	*	*	*	*	*	*	*	*	*	*	*	*	*	*	*	*
A 45483	£175	€210	Imperial Tray, 1/1 GN, 60mm	*	*	*	*	*	*	*	*	*	*	*	*	*	*	*	*
A 45723	£196	€235	Imperial Sheet, 1/1 GN	*	*	*	*	*	*	*	*	*	*	*	*	*	*	*	*
A 45481	£175	€210	Imperial Grilling Grid, 1/1 GN	*	*	*	*	*	*	*	*	*	*	*	*	*	*	*	*
A 113151	£101	€121	Baking Tray Non-Stick, 1/1 GN	*	*	*	*	*	*	*	*	*	*	*	*	*	*	*	*
A 113152	£117	€140	Baking Tray Perforated Non-Stick, 1/1 GN	*	*	*	*	*	*	*	*	*	*	*	*	*	*	*	*
A 45445	£96	€115	Baking Mat Silicone, 1/1 GN	*	*	*	*	*	*	*	*	*	*	*	*	*	*	*	*
A 45725	£128	€153	Imperial Multi-Tray, 1/1 GN	*	*	*	*	*	*	*	*	*	*	*	*	*	*	*	*
A 45480	£128	€153	Steamfry Basket, 1/1 GN	*	*	*	*	*	*	*	*	*	*	*	*	*	*	*	*
A 45733	£138	€166	Rib Rack, 1/1 GN	*	*	*	*	*	*	*	*	*	*	*	*	*	*	*	*
A 41120	£64	€77	Chicken Grill, 1/2 GN - for 4 pcs.	*	*	*	*	*	*	*	*	*	*	*	*	*	*	*	*
A 33089	£128	€153	Chicken Grill, 1/1 GN - for 8 pcs.	*	*	*	*	*	*	*	*	*	*	*	*	*	*	*	*
A 45722	£149	€179	Imperial Potato Spikes, 1/1 GN	*	*	*	*	*	*	*	*	*	*	*	*	*	*	*	*
A 45081	£56	€66	Grill, stainless steel, 1/1 GN	*	*	*	*	*	*	*	*	*	*	*	*	*	*	*	*
A 45203	£94	€113	Grill, stainless steel, 2/1 GN				*	*	*				*	*	*				

Connectivity

FOR MODELS

MODEL	PRICE £	PRICE €	DESCRIPTION	LQC106	LQC110	LQC120	LQC206	LQC210	LQC220	LQH106	LQH110	LQH120	LQH206	LQH210	LQH220	LQC106PT	LQC110PT	LQH106PT	LQH110PT
A 111738	£1279	€1534	Open Kitchen App**	*	*	*	*	*	*	*	*	*	*	*	*	*	*	*	*

It is recommended that a water treatment unit is installed with all Lincat Invoq Ovens. Any water related issues which arise with Lincat Invoq Ovens not fitted with a suitable water treatment unit will not be covered under warranty.

****All ovens are supplied with a WIFI module as standard. Price includes onboarding via 'Power House Dynamics' and 12 months of usage. 6 month free trial available with limited functionality in Power House Dynamics.**



Invoq | Bake

Invoq Bake allows you to widen the selection of products you can bake. From breakfast pastries to lunchtime snacks, sweet treats to take-away ready meals - and everything in between

Instead of revolving the racks, we circulate the air.

With Invoq Bake, the hot air moves, not what you're baking.

A highly sophisticated, sensor controlled, smart fan distributes and circulates the air. It creates trajectories that envelop every item in the oven consistently, no matter what rack it is sitting on. Top to bottom, side to side, reversing automatically.

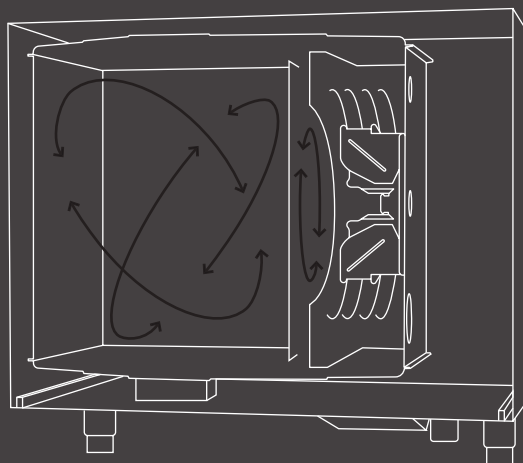

Convection and steam are optimally balanced.

Moist on the inside. –
The oven, not just the pastry.

Controlling the humidity level while baking can have a dramatic impact on results, providing that you can control it with speed and accuracy.

Invoq Bake gives you this degree of fine intervention by allowing you to introduce moisture directly into the oven cavity, quickly, on the fly. It also means you can confidently bake several different products at the same time.

An advanced steam production system injects moisture directly into the oven's heating elements, with immediate effect. Steam is produced without waiting for any water to boil and with minimum energy demand.

The steam injection system is backed up by an active air inlet, promoting crispness and crunchiness.



Benefits From Adding Humidity

- Crispy and colourful crust.
- Increased product volume.
- Maintained moisture level inside the product for a longer shelf life.
- Protecting the surface of delicate products like croissants.
- Controlled proving environment.
- One piece of equipment for desserts, cakes and breads.

Invoq | Bake

A range of fan speeds to suit a range of baked items.

Invoq Bake's fan is so sensitive and controllable, it instinctively knows how to treat a meringue differently from a baguette.

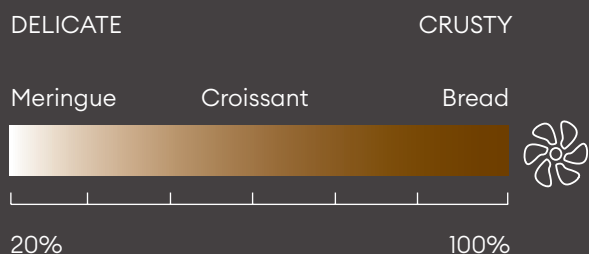

CombiSense

The automatic humidity system offers you the possibility to bake your product with a shiny, crisp and crunchy finish while maintaining a moist centre.

No cross-contamination of flavours.

You can actually bake muffins and garlic bread at the same time without flavour transferring from one product to the other.





An oven controlled by a tablet.



SmartBaker. Change from manual to automatic.

SmartBaker is an automatic feature for intelligent baking. See, follow and learn from the oven to develop your own recipes. Select the type of food, desired cooking method and core temperature. Press start and the oven will guide you step by step through the process for a perfect result. Save your favourites and edit, if needed.



QSR. Make no mistake, anyone can stick to this recipe.

QSR - Quick Select Recipes - enable any member of your team, no matter how experienced, to bake at a consistently high quality. QSR saves time and makes mistakes less likely.



ClimateControl. Be in charge of the environment in your oven.

ClimateControl ensures optimised processes and shorter cooking times. Key design elements produce optimised air distribution and airflow, improved humidity accuracy and faster moisture evacuation. Everything is perfectly controlled for optimum quality.



CareCycle. Customise the way you keep spotless.

Although a clean oven is a necessity, cleaning can interrupt service or make your workflow more complex. **CareCycle** is a phosphate free tablet-based way to clean, with seven programs ranging from Eco to Turbo. It produces excellent results with surprisingly little water or chemicals, and you can program **CareCycle** to get to work at your convenience.

Invoq | Bake



Sustainability.

Convection 

19% less energy
used per
running hour

Technology behind the scenes:

- Triple layer glass door
- Improved airflow contributing to the Maillard reaction
- Improved air intake - three times faster dehumidification
- Energy-efficient insulation

Cleaning 

70.7% less costs
27% less water
63% less time

Technology behind the scenes:

- Recirculating cleaning system
- Less and greener chemicals
- Cleaning programs to match your needs

Your savings 

Cost savings
of £335/€385
per year

Technology behind the scenes:

- Ten hours a day and one medium cleaning
- Seven days a week
- 50 weeks a year

Based on a kWh price of € 0.46 and a water price of € 1.45 per m3. Comparison: Invoq Bake 9 - 400x600 EN up against predecessor model.



Invoq | Bake

Invoq Bake

- All ovens are 50 Hertz, 3 phase



MODEL	LQB6	LQB9	LQB16
Price	£9498/€11,398	£13,124/€15,749	£20,958/€25,149
Height (mm)	851	1081	1730
Width (mm)	917	917	917
Depth (mm)	908	908	923
Power (kW)	10.3	19.3	38.5
Capacity (baking sheets mm)	6 x 400x600	9 x 400x600	16 x 400x600
No. of meals per day	90	150	300
Weight (kg)	127	159	276

Invoq Bake PassThrough

- Please see page L56 for more information on **PassThrough**
- All ovens are 50 Hertz, 3 phase



MODEL	LQB6PT	LQB9PT
Price	£12,528/€15,035	£18,500/€22,200
Height (mm)	851	1081
Width (mm)	917	917
Depth (mm)	1059	1059
Power (kW)	10.3	19.3
Capacity (baking sheets mm)	6 x 400x600	9 x 400x600
No. of meals per day	90	150
Weight (kg)	149	184

* Please refer to pages L117 to L118 for electricity supply requirements

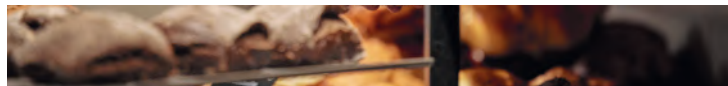

Invoq Bake - Accessories, Options and Consumables

Oven Stands

FOR MODELS

MODEL	PRICE £	PRICE €	DESCRIPTION	LQB6	LQB9	LQB16	LQB6PT	LQB9PT
A LQSO1	£548	€658	Static Open Stand	•	•		•	•
A LQSR1	£1217	€1461	Static Stand with Runners and Chemical Drawer	•	•		•	•
A LQCK	£366	€440	Castor Kit for LQSO1 and LQSR1 - 2 x Braked, 2 x Unbraked	•	•		•	•

Trolley System

FOR MODELS

MODEL	PRICE £	PRICE €	DESCRIPTION	LQB6	LQB9	LQB16	LQB6PT	LQB9PT
A 107591	£1997	€2398	Invoq Roll-in trolley 16 EN - 400x600 80 mm 16 trays L-shaped			•		

Stacking Kit

SEE PAGE L57 FOR MORE INFORMATION

FOR MODELS

MODEL	PRICE £	PRICE €	DESCRIPTION	LQB6	LQB9	LQB16	LQB6PT	LQB9PT
A 107800/965	£1283	€1539	Stackit, electric + Low Floor Stand	•				
A 111725/965	£1283	€1539	Stackit, PassThrough, electric + Low Floor Stand				•	

Drain Lift Solution

SEE PAGE L60 FOR MORE INFORMATION

FOR MODELS

MODEL	PRICE £	PRICE €	DESCRIPTION	LQB6	LQB9	LQB16	LQB6PT	LQB9PT
A 110891	£722	€867	Drain Lift System, single oven, upgrade kit	•	•	*	•	•
A 110892	£722	€867	Drain Lift System, stacked oven, upgrade kit	•			•	•

Extraction Hoods

SEE PAGE L58 - L59 FOR MORE INFORMATION

FOR MODELS

MODEL	PRICE £	PRICE €	DESCRIPTION	LQB6	LQB9	LQB16	LQB6PT	LQB9PT
A 110907	£4163	€5116	Condensation Hood, Upgrade Kit	•	•			
A 110906	£4163	€5116	Condensation Hood, PassThrough, Upgrade Kit				•	•
A 110903	£4770	€5324	Condensation Hood, 20-l Roll-In, Upgrade Kit			•		
A 110905	£4770	€5324	Condensation Hood Stackit, Upgrade Kit	•	•			
A 110904	£4770	€5324	Condensation Hood Stackit, PassThrough, Upgrade Kit				•	•
A 111458	£7035	€8442	Hoodini Hood, single units, Upgrade Kit	•	•			
A 111457	£7412	€8894	Hoodini Hood, single units, PassThrough, Upgrade Kit				•	•
A 111456	£10,742	€12,891	Hoodini Hood, stacked units, Upgrade Kit	•	•			
A 111455	£11,114	€13,337	Hoodini Hood, stacked units, PassThrough, Upgrade Kit				•	•

*factory fitted option only

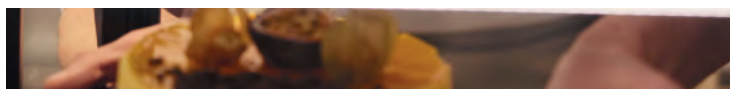

Invoq Bake - Accessories, Options and Consumables

Heat Shields

FOR MODELS

MODEL	PRICE £	PRICE €	DESCRIPTION	LQB6	LQB9	LQB16	LQB6PT	LQB9PT
A 108120	£330	€396	Heat shield Bake 6	•			•	
A 108121	£359	€431	Heat shield Bake 9		•			•
A 108124	£440	€528	Heat shield Bake 16			•		

Water Treatment

FOR MODELS

MODEL	PRICE £	PRICE €	DESCRIPTION	LQB6	LQB9	LQB16	LQB6PT	LQB9PT
C 30500546	£846	€1016	Hydro Shield 6000 (XL) Water Filter Cartridge	•	•	•	•	•
S 108139	£1257	€1508	Hydro Shield 6000 (XL) Water Filter Kit - inc. Filter, Filter Head and Hose	•	•	•	•	•

Detergent

FOR MODELS

MODEL	PRICE £	PRICE €	DESCRIPTION	LQB6	LQB9	LQB16	LQB6PT	LQB9PT
C 106032	£200	€241	CareCycle Clean tablets - 150	•	•	•	•	•
C 106033	£200	€241	CareCycle Descale tablets - 150	•	•	•	•	•
A 110247	£371	€427	Hand Shower	•	•	•	•	•

Grills, Trays and Sheets

† SEE PAGE L61 FOR MORE INFORMATION

FOR MODELS

MODEL	PRICE £	PRICE €	DESCRIPTION	LQB6	LQB9	LQB16	LQB6PT	LQB9PT
A 107840	£597	€717	MultiRack 6-1/1 GN and 400 x 600 †	•			•	
A 107846	£707	€848	MultiRack 10-1/1 GN and 400 x 600 †		•			•
A 45438	£101	€121	Baking tray non-stick, 400x600 EN	•	•	•	•	•
A 45703	£128	€153	Baking tray perforated non-stick, 400x600 EN	•	•	•	•	•
A 45444	£96	€115	Baking mat silicone, 400x600 EN	•	•	•	•	•

Connectivity

FOR MODELS

MODEL	PRICE £	PRICE €	DESCRIPTION	LQB6	LQB9	LQB16	LQB6PT	LQB9PT
A 111738	£1279	€1534	Open Kitchen App**	•	•	•	•	•

It is recommended that a water treatment unit is installed with all Lincat Invoq Ovens. Any water related issues which arise with Lincat Invoq Ovens not fitted with a suitable water treatment unit will not be covered under warranty.

****All ovens are supplied with a WIFI module as standard. Price includes onboarding via 'Power House Dynamics' and 12 months of usage. 6 month free trial available with limited functionality in Power House Dynamics.**

Invoq



PassThrough. The fastest route.

In one side.
Out the other.

Invoq PassThrough features an ingenious double door system. Food enters from the bakery side. Then, when it is cooked, it is removed from the service side.

Not only does this reduce the risk of cross contamination, it shortens the trips the server needs to make - they don't even need to enter the bakery.

Food is clearly visible to the customer and is illuminated by a powerful, low-energy LED light, which both adds a bit of theatre and encourages impulse buying.

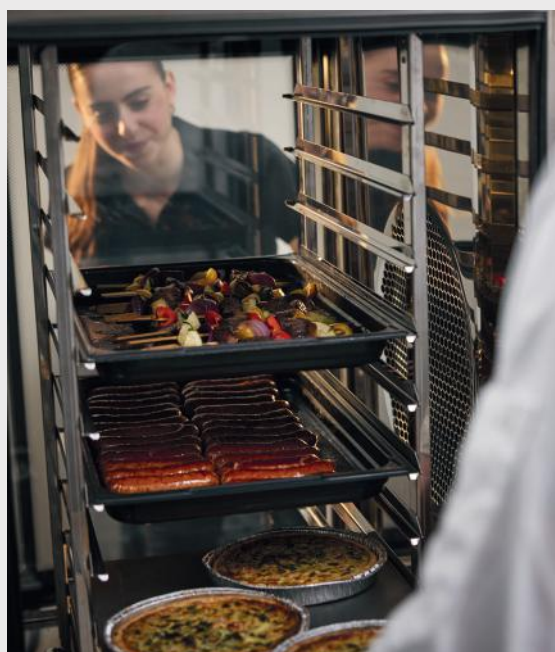

Benefits at a glance

- Two-door oven for optimal workflow
- Avoid cross contamination - clear separation of food
- Ideal for display baking
- Attract customers and increase sales
- Improve logistics in your bakery and save time
- Space optimised system
- Improved safety

Invoq

StackUp saves floor space.

Double your capacity.

Stacking two ovens saves you valuable floor space. You can easily adjust the cooking capacity to the number of guests. And switch off the oven that you do not use in off-peak periods to avoid overcapacity and save money on energy.

Maximum flexibility.

By stacking two Invoq ovens, you get optimal baking flexibility. You can for instance prove bread in the bottom oven, while baking pastries in the top oven. You can choose different rack sizing for the two ovens for further flexibility.

Combi

- Combine two steam technologies

Bake

- Combine two steam/bake technologies



Invoq



Condensation Hood Overview

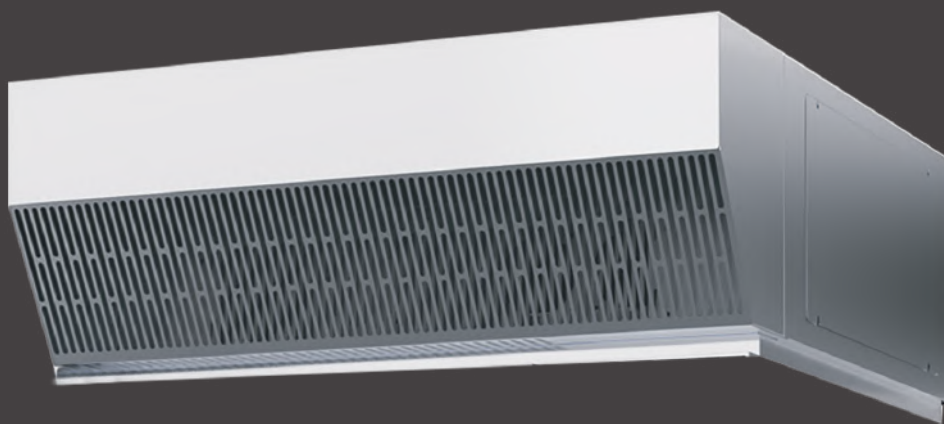

Air quality. Safely and efficiently.

By combining your Invoq oven with a condensation hood, efficiently extract and condense excess steam to drain. The result is less humidity, drier surfaces, and a safer and more comfortable working environment.

Concentrate your entire food production in just one square metre. And you have the freedom to place the oven anywhere you want.

- Ensuring efficient extraction and condensing of excess steam.
- Removing up to 93% of the humidity from the oven exhaust.
- The system is controlled by the oven.
- Condensed steam is discharged through the oven's drain system.
- No external connection required.



Invoq

Invoq Hoodini Overview

Liberate your kitchen from traditional hood systems.

Get grease, vapours and contaminated air out of your kitchen without complex and pricey roof venting. Controlled by the oven, Hoodini is retrofittable and designed for seamless integration*.

Why Hoodini over a traditional hood system?

- No top clearance and external air extraction ducts required
- Eliminate the need for time consuming and labour intensive filter cleaning
- Say goodbye to ongoing expenses for filter replacements
- No service charges – reduce maintenance costs and eliminate service charges



This is how the Invoq Hoodini works:



1. Main Fan Activation

The main fan starts, efficiently pulling cooking vapours out of the oven cavity.



3. Condensation process

Vapours pass over the condenser, where cooling results in the formation of water particles that drip towards the drain.



2. Particle separation

Heavy particles drop towards the drain, while lighter particles are directed towards the condenser.



4. Catalytic converter action

Remaining vapours pass through the platinum and palladium-coated catalytic converter, reducing gases to harmless carbon dioxide and water. 5. Recirculation: Harmless gases are returned to the oven cavity to restart the process, ensuring a continuous and efficient cooking experience.

*Hoodini requires a 230-volt single-phase plug within a 3-meter radius. *Retrofittable on Invoq only, CombiSlim Hoodini is factory fit only.*

Invoq



Drain Lift System

Unleash installation freedom.

Say goodbye to drainage issues and costly external pumps – our all-in-one solution is here to transform your culinary experience.

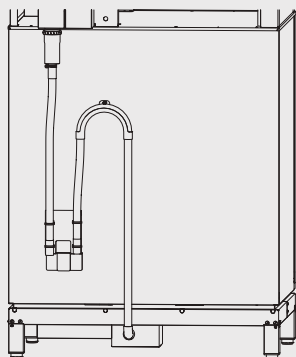

Drain lift system on a Stackit oven

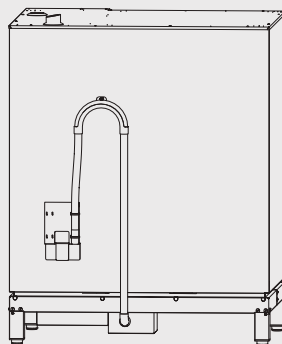

Drain lift system on a standard oven

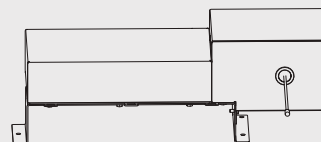

Drain box and pump assembly

The drain lift system for Invoq ovens is a ready-to-install, external, automatic drainage system with an integrated pump, intended to lift wastewater out into a wall mounted drain.

This system is perfect for various kitchen setups with Invoq ovens; stand alone or Stackit solution. Frequently seen in basement kitchens and other locations with wall-mounted drains, its adaptability makes it an ideal choice for a wide range of culinary environments. The tundish allows for a wall installation of a height up to 350 mm.

This is a factory fitted option on 20 grid and Bake 16 ovens.



Invoq

MultiRack for multiuse.

Combine your 400 x 600mm baking sheets with your 1/1 gastronorm trays giving you a wide variety of accessories to use at the same.

MultiRack for 6 grid Invoq Combi and Hybrid and Invoq Bake 6 gives 5 trays with 100mm rack distance. MultiRack for 10 grid Invoq Combi and Hybrid and Invoq Bake 9 gives you 8 trays with a distance of 110mm.



Achieve full flexibility by expanding your accessories

The patented aluminium alloy of the 1/1 GN Imperial® accessories provides an optimal ability to absorb, store and release heat. The accessories enable perfect cooking and baking results making sure that there is no limit to what you can cook in your Invoq oven.





blu°

KEEPING IT COOL



In busy kitchens where speed is crucial, caterers need quick and easy access to food at the point of cooking, Blu° refrigerated chef bases provide the ideal solution.

Our Blu° chef bases, brought to you in conjunction with our market leading sister company Desmon, Blu° bases allow easy access to stored, chilled food at the point of cooking.

Designed to accommodate heavy-duty Opus 800 series equipment such as chargrills, griddles and induction hobs, the unit has self-closing, heavy-duty drawers capable of holding 1/1 GN 100mm-deep containers, providing convenient bulk storage for meat and fish.

The Blu° chef bases are powered by a three-pin plug, therefore requiring no installation. For ease of cleaning, the units have removable drawers, rounded interior corners and removable rubber magnetic door gaskets. They are supplied on castors, making it simple to pull the unit out for a deep clean. As with all Lincat products, the Blu° chef bases come with a two-year warranty.

Ideally suited for...

Blu° chef bases are perfect for the most demanding of kitchens allowing easy access to stored, chilled food at the point of cooking.



Large chain pubs and restaurants

Is your kitchen constantly under pressure to deliver delicious dishes at high volumes? If so, you'll find Blu° chef bases speed up operations.



High Volume Kitchens

If you need to cook a vast quantity of meals, Blu° chef bases will improve the efficiency in your kitchen.

Benefits at a glance

- Designed to accommodate heavy equipment, including Opus 800 Series chargrills, griddles and hobs
- Drawers hold 1/1 GN 100mm deep containers
- Allows bulk storage and easy access to food at point of cooking
- Ideal for meat and fish
- Adjustable thermostat -2° to + 8°C
- Self-closing heavy duty drawers
- Supplied on castors as standard

Chef Bases

- Three widths available – 800mm, 900mm and 1200mm
- Designed to accommodate heavy equipment including Opus 800 Series chargrills, griddles and hobs
- Drawers hold 1/1 GN 100mm deep container/s
- Allows bulk storage and easy access to food at point of cooking
- Ideal for meat and fish
- Adjustable digital thermostat -2°C to +8°C
- Self-closing heavy duty drawers
- Energy grade D
- Supplied on castors as standard



 Chef bases									
MODEL	PRICE £	PRICE €	H	W	D	NO. OF DRAWERS	1/1GN CAPACITY	POWER	WT
BD20032	£4564	€5248	615	838	826	2	2	0.6kW	140
BD20036	£4747	€5459	614	916	826	2	2	0.6kW	144
BD20048	£5406	€6216	614	1220	826	2	4	0.6kW	174





Phoenix offers performance and power without the frills, at a cost-effective price point

Robust and durable, the medium duty Phoenix series includes both gas and electric models, and has been designed to cope with the day-to-day demands of the busiest of kitchens.

The series is ideal for the value-conscious buyer who doesn't want to sacrifice quality and performance.

Ideally suited for...

The Phoenix series is ideal for anyone who needs power which packs a punch, while keeping costs to a minimum. They include:



Care homes

The Phoenix series comes with the power and capacity to deliver quality meals at set times in a care home environment.



Schools

Looking for a cost-effective solution for delivering high-volume school meals? The Phoenix series provides just that, with the perfect combination of power and performance.



Smaller pubs and restaurants

Robust enough to cope in busy kitchens, the Phoenix series will keep up with the demands that you place on it.

The Phoenix series provides power and performance without having to break the bank.

Benefits at a glance

- Medium duty
- Cost-effective
- Robust
- Performance guaranteed
- Powerful
- Gas and electric models
- Easy to clean



Bratt Pans

Turn up the volume! Solve bulk cooking needs even at high temperatures. Perfect for bulk cooking in a variety of methods - allows users to braise, shallow fry or boil a variety of food products in large quantities.

Gas Bratt Pan



- Large 80 litre capacity
- Temperature control flexible from 45°C to 295°C - maximum flexibility to meet different cooking needs
- Handwheel controlled manual tilting for a smooth tilt
- Large pouring spout for easy emptying of the pan, reducing mess
- Incoloy alloy corrosion resistant elements
- AISI 304 grade stainless steel for uniform heat distribution, perfect for high temperature cooking
- Robust 12mm thick base
- Easy clean stainless steel design
- Also supplied with LPG jets for conversion on site

Gas Bratt Pan							
MODEL	PRICE £	PRICE €	H	W	D	POWER	WT
PHGBP80/N	£6397	€7676	970	800	900	20kW	180

MODEL	PRICE £	PRICE €	DESCRIPTION
A CA01	£691	€795	Control Kit (4)

2
YEAR

 UK parts
and labour
warranty

 Export
parts
warranty

on all Lincat products

Electric Bratt Pan

- Large 80 litre capacity
- Temperature control flexible from 45°C to 295°C - maximum flexibility to meet different cooking needs
- Handwheel controlled manual tilting for a smooth tilt
- Large pouring spout for easy emptying of the pan, reducing mess
- High thermal efficiency stainless steel tubular burners
- AISI 304 grade stainless steel for uniform heat distribution, perfect for high temperature cooking
- Robust 12mm thick base
- Easy clean stainless steel design



Electric Bratt Pan							
MODEL	PRICE £	PRICE €	H	W	D	POWER	WT
PHEBP80	£6397	€7676	970	800	900	10kW	180

MODEL	PRICE £	PRICE €	DESCRIPTION
A CA01	£691	€795	Control Kit (4)

‡ Zones can be boosted to 3kW for up to 10 minutes while the others will be reduced.
 †/On PHER01/SPH - 6 x 1.5kW zones and 4kW oven

Gas Oven Range

- High quality, excellent performance, value for money
- Powerful 6kW burners - the pan will heat up quicker, speeding up processes such as boiling and sautéing, achieving a caramelised colour faster
- Fully pressed hob - simpler and quicker to clean
- Twin heavy-duty cast iron supports, built to withstand the rigours of the busiest kitchen
- Low flue, hob top accommodates larger pans
- Flame failure protection
- Powerful 10kW oven - the oven will heat up faster and recover more quickly when loaded
- Large 4 x GN1/1 capacity oven enabling four different foods to be cooked simultaneously
- 2 shelves and 5 shelf positions maximise oven space
- Piezo ignition to oven for simple operation

- Double insulated doors and side panels for safe operation, efficiency and economy
- Robust and durable stainless steel design
- Castors supplied as standard, not as a chargeable extra



6 burner gas oven range							
MODEL	PRICE £	PRICE €	H	W	D	POWER	WT
PHGR01/N	£2952	€3395	900	900	800	46kW	145
PHGR01/P	£2952	€3395	900	900	800	45.5kW	145
Internal usable dimensions			405	715	540		

MODEL	PRICE £	PRICE €	DESCRIPTION
A OA8902	£571	€658	Splashback/shelf

Dual Fuel Oven Range

- High quality, excellent performance, value for money
- Powerful 6kW burners - the pan will heat up quicker, speeding up processes such as boiling and sautéing, achieving a caramelised colour faster
- Fully pressed hob - simpler and quicker to clean
- Twin heavy-duty cast iron supports, built to withstand the rigours of the busiest kitchen
- Low flue, hob top accommodates larger pans

- Flame failure protection
- Powerful 6kW twin fan assisted oven for more even cooking
- Large 4 x GN1/1 capacity oven enabling four different foods to be cooked simultaneously
- 2 shelves and 5 shelf positions maximise oven space
- Double insulated doors and side panels for safe operation, efficiency and economy
- Robust and durable stainless steel design
- Castors supplied as standard, not as a chargeable extra



6 burner dual fuel oven range							
MODEL	PRICE £	PRICE €	H	W	D	POWER	WT
*PHDR01/N	£5390	€6199	900	900	800	45kW	145
*PHDR01/P	£5390	€6199	900	900	800	40.2kW	145
Internal usable dimensions			400	715	530		

MODEL	PRICE £	PRICE €	DESCRIPTION
A OA8902	£571	€658	Splashback/shelf

2
YEAR

UK parts
and labour
warranty

Export
parts
warranty

on all Lincat products

Induction Oven Ranges

- Ideal for small to medium cook-to-order operations
- 190mm diameter zones: six 1.85kW zones (PHER01) or four 1.85kW zones (PHER02)
- Boost zones to 3kW for 10 minutes; other zones will drop during boosting
- Energy-efficient: cuts power when no pan is detected, reducing costs and kitchen heat
- Durable, easy-to-clean 6mm high-impact glass ceramic surface
- Oven capacities: 6 x GN1/1 (PHER01) or 3 x GN1/1 (PHER02) for multi-dish cooking
- Fan-assisted ovens: 6kW twin (PHER01) or 3kW single (PHER02) for even cooking
- Highly insulated oven for consistent temperature and minimal heat loss
- Sturdy stainless-steel construction
- PHER01 offers single or three-phase options
- Heavy-duty castors included as standard



Lincat

4 zone induction oven range								
MODEL	PRICE £	PRICE €	H	W	D	PHASE	POWER	WT
*PHER02	£6080	€6992	900	600	805	1 or 3	11.4kW	103
Internal usable dimensions			405	495	530			



Lincat

6 zone induction oven range								
MODEL	PRICE £	PRICE €	H	W	D	PHASE	POWER	WT
*PHER01	£8638	€9933	923	900	817	3	17.1kW	145
*PHER01/SPH	£8638	€9933	923	900	817	1	13kW	145
Internal usable dimensions			440	725	512			



Counter Top Induction Hob

- For where you need power in a small footprint
- Compact sleek design
- Two cooking zones
- High efficiency - delivers almost twice the cooking power of a similarly rated gas hob
- Functional and attractive profile, perfect for front of house theatre-style cooking
- When you need intense heat to get you cooking fast, zones can be boosted to 3kW for up to 10 minutes. Power to other zones will drop during the boost period
- Easy to clean, heavy duty 6mm thick high impact resistant glass



Lincat

Counter Top Induction Hob							
MODEL	PRICE £	PRICE €	H	W	D	POWER	WT
*PHEH01	£2574	€2960	146	350	705	3.7kW	12

Electric Adjustable Salamander Grill

- Fast heat up 'Hi-Light' elements - ready to cook in just 8 seconds
- Height adjustable grill hood reduces heat loss to surrounding area
- Three cook zones - only turn on the area you need
- Energy saving
- GN 1/1 compatible
- 15 minute timer



Lincat

Electric Salamander Grill							
MODEL	PRICE £	PRICE €	H	W	D	POWER	WT
*PHEAS01	£3890	€4474	544	600	545	4.5kW	69

MODEL	PRICE £	PRICE €	DESCRIPTION
A BR75	£263	€303	Wall bracket

* Please refer to pages L117 to L118 for electricity supply requirements

SILVERLINK 600



Configure your cooking space with the custom-build Silverlink 600 range

The Silverlink 600 series of 600mm deep modular cooking equipment is designed for flexibility, enabling you to configure your cooking space just the way you like it.

The range includes countertop, base units, and freestanding versions of a wide variety of kitchen equipment, including oven ranges, boiling tops, ovens, pasta boilers, bain maries, fryers, chip scuttles, grills and griddles

The medium-duty Silverlink 600 range is perfect for shift service output, such as those establishments serving lunch and dinner.

Ideally suited for...

The Silverlink 600 series is suitable for a variety of locations where flexibility is appreciated, including the following:



Care homes

The medium-duty series is aimed at locations with shift service output. This makes it perfect for care homes with set meal patterns.



Larger café bars

With every piece of equipment you could hope to find in a kitchen, your café bar will be able to provide a range of delicious dishes.



Village halls and community centres

Make the most of the modular flexibility to configure your food preparation area your way.



Small to medium pubs and restaurants

Ideal for pubs and restaurants with shift service operations looking for flexible solutions in their kitchen.

Modular cooking equipment designed for flexibility, enabling you to configure your cooking space just the way you like it.

Benefits at a glance

- 600mm deep
- Medium duty
- Modular flexibility
- Free standing and counter top units
- Ideal for establishments serving on a shift basis (lunch and dinner)
- Gas and electric models
- Easy to clean

SILVERLINK 600

All gas power ratings are nominal values. All Silverlink 600 counter top units when mounted on optional floor stands or pedestals provide a uniform nominal hob height of 900mm.

Gas Oven Ranges

- Fully pressed and sealed hob tops for easy cleaning
- Robust, easy-clean vitreous enamelled cast iron pan supports
- Low level flue maximises working area and enables you to use large stock pots
- Large capacity oven with a stainless steel interior for easy cleaning
- Oven and hob burners with automatic flame failure device for added safety
- Castors at rear to enable unit to be pulled out for deeper cleans



Electric Oven Range

- Compact 600mm deep footprint - perfect for care homes as well as smaller pubs and restaurants
- Six hotplates 3 x 2.0kW, 3 x 1.5kW (ESLR9C), four hotplates 2 x 2.0kW, 2 x 1.5kW (ESLR6C) with six-position control knob for each plate - higher power for sautéing at the front, lower power to the rear ideal for simmering
- Automatic power reduction, if the pan boils dry or is removed, prolonging hotplate life
- Easy clean fully pressed and sealed hob
- Powerful 6kW twin assisted oven (ESLR9C) and 4kW fan assisted oven (ESLR6C, ESLR9C/SPH) for uniform heat distribution and consistent cooking
- To suit install requirements the ESLR6C can be wired as either single or three phase and the ESLR9C is available in single or three phase
- Double insulated doors, side and back panels providing safer operation, greater efficiency and economy
- Castors at rear to enable unit to be pulled out for deeper cleans



4 burner gas range									
MODEL	PRICE £	PRICE €	H	W	D	POWER	WT		
SLR6C/N	£2873	€3305	956	600	600	23.8kW	80		
SLR6C/P	£2873	€3305p	956	600	600	23.8kW	80		
Internal usable dimensions			360	480	342				

Supplied with castors at rear as standard

Splashback and plate shelf

MODEL	PRICE £	PRICE €	DESCRIPTION	H
A SLR6/SB	£307	€354	For model SLR6	450

Splashbacks should not be used when ranges are fitted with castors

6 burner gas range									
MODEL	PRICE £	PRICE €	H	W	D	POWER	WT		
SLR9C/N	£3330	€3830	956	900	600	35.5kW	106		
SLR9C/P	£3330	€3830	956	900	600	35.5kW	106		
Internal usable dimensions			400	725	342				

Supplied with castors at rear as standard

Splashback and plate shelf

MODEL	PRICE £	PRICE €	DESCRIPTION	H
A SLR9/SB	£324	€373	For model SLR9	450

Splashbacks should not be used when ranges are fitted with castors

4 plate electric range									
MODEL	PRICE £	PRICE €	H	W	D	POWER	WT		
*ESLR6C	£2795	€3214	932	600	670	11kW	73		

Supplied with castors at rear as standard

Key

H = Height (mm)
W = Width (mm)
D = Depth (mm)
WT = Packed Weight in kg

6 plate electric range									
MODEL	PRICE £	PRICE €	H	W	D	POWER	WT		
*ESLR9C	£3474	€3995	932	900	670	16.5kW	110		
*ESLR9C/SPH	£3474	€3995	932	900	670	13kW	110		
Internal usable dimensions			428	725	342				

670mm deep including fan housing

Supplied with castors at rear as standard

Electric Ovens

- Stainless steel interior with radiused corners and removable side shelf supports for easy cleaning
- Able to support a suitably sized Silverlink 600 counter-top unit
- Side opening doors, with robust hinges and ball catch, to give safe, easy access
- Fan-assisted models give superior heat distribution with a rapid cool down feature
- Compatible with SLI42



Electric ovens									
MODEL	PRICE £	PRICE €	H	W	D	POWER	WT		
V6	£1757	€2020	650 - 674	600	623	3kW	57		
Internal usable dimensions			420	470	335				
V6/F	£1999	€2298	650 - 674	600	623	3kW	58		
Internal usable dimensions			420	470	335				

V6/F - fan assisted

Electric ovens with glass doors									
MODEL	PRICE £	PRICE €	H	W	D	POWER	WT		
V6/D	£1887	€2171	650 - 674	600	623	3kW	57		
Internal usable dimensions			420	470	335				
V6/F/D	£2166	€2491	650 - 674	600	623	3kW	58		
Internal usable dimensions			420	470	335				

V6/F - fan assisted

Large electric ovens									
MODEL	PRICE £	PRICE €	H	W	D	POWER	WT		
V7	£2386	€2744	650 - 674	750	600	3kW	66		
Internal usable dimensions			430	558	390				
*V7/4	£2497	€2872	650 - 674	750	600	4kW	60		
Internal usable dimensions			430	558	335				

V7 & V7/4 - fan assisted

MODEL	PRICE £	PRICE €	DESCRIPTION
A V6/T	£142	€163	Top for V6 series ovens

See page L77 for stands for V6 and V7 ovens

MODEL	PRICE £	PRICE €	DESCRIPTION
A V7/T	£152	€176	Top for V7 series ovens

* Please refer to pages L117 to L118 for electricity supply requirements

SILVERLINK 600

All gas power ratings are nominal values. All Silverlink 600 counter top units when mounted on optional floor stands or pedestals provide a uniform nominal hob height of 900mm.

Electric Boiling Tops

- Fully pressed and sealed hob tops for easy cleaning
- Automatic power reduction, if pan boils dry or is removed - prolonging hotplate life
- Six-position switches control each plate
- 180mm / 7" sealed hotplates



2 plate boiling top							
MODEL	PRICE £	PRICE €	H	W	D	POWER	WT
HT3	£556	€639	290	300	600	3kW	12

4 plate boiling top							
MODEL	PRICE £	PRICE €	H	W	D	POWER	WT
*HT6	£822	€946	290	600	620	7kW	21

4 plate boiling top							
MODEL	PRICE £	PRICE €	H	W	D	POWER	WT
*HT7	£973	€1119	290	750	620	7kW	23

Gas Boiling Tops

- Powerful gas burners with flame failure device for added safety
- Fully pressed and sealed hob tops for easy cleaning
- Robust, easy-to-clean vitreous enamelled cast iron pan supports
- Low level flue maximises working area and enables you to use large stock pots

Product Codes

/N = natural gas /P = propane gas Btu/hr = kW x 3412



2 burner boiling top							
MODEL	PRICE £	PRICE €	H	W	D	POWER	WT
HT3/N	£1059	€1219	306	300	626	9kW	15
HT3/P	£1059	€1219	306	300	626	9kW	15

4 burner boiling top							
MODEL	PRICE £	PRICE €	H	W	D	POWER	WT
*HT6/N	£1647	€1895	306	600	626	18kW	26
*HT6/P	£1647	€1895	306	600	626	18kW	26

6 burner boiling top							
MODEL	PRICE £	PRICE €	H	W	D	POWER	WT
HT9/N	£2141	€2462	306	900	626	27kW	37
HT9/P	£2141	€2462	306	900	626	27kW	37

Induction Hobs

- High power – almost twice the cooking power of a similarly rated gas hob
- Boost function on multi-zone models delivers power when it's most needed
- 6mm thick high impact resistant glass ceramic surface will withstand hard knocks and is easy to clean
- Suites perfectly with other Silverlink 600 products to create a professional cookline
- Easy to use rotary controls complete with LED display of power level
- Pan detection function cuts power when no pan is present, preventing harm to users and utensils, while saving energy
- Automatic heat up function switches to a preset power level after full power heat up
- Easy to change filter, built into the base of the unit
- Powerful internal cooling fan and overheat protection for long service life
- These units are not suitable for mounting on Silverlink 600 heated pedestals
- Compatible with V6 ovens

2

UK parts and labour warranty
Export parts warranty
on all Lincat products



Lincat

Lincat

Lincat

Lincat

1 zone induction hob								1 zone induction hob								2 zone induction hob								4 zone induction hob							
MODEL	PRICE £	PRICE €	H	W	D	POWER	WT	MODEL	PRICE £	PRICE €	H	W	D	POWER	WT	MODEL	PRICE £	PRICE €	H	W	D	POWER	WT	MODEL	PRICE £	PRICE €	H	W	D	POWER	WT
SLI3	£1668	€1918	290	450	600	3kW	22	SLI3W	£2261	€2601	290	450	600	2.4kW	20	SLI21	£1616	€1859	290	450	600	3kW	22	SLI42	£2858	€3287	290	600	600	2 x 3kW	31

SILVERLINK 600

All gas power ratings are nominal values. All Silverlink 600 counter top units when mounted on optional floor stands or pedestals provide a uniform nominal hob height of 900mm.

Electric Counter Top Fryers

- Front mounted controls ensure safe working practice
- Hinging element with safety cut-out provides easy access to tank for cleaning
- High quality grade 304 stainless steel fryer tanks, fully welded to hobs for added strength and a smooth, easy clean seamless finish
- Thermostatic control with fail-safe top temperature cut out maintains accurate oil temperature and ensures safe operation
- Heavy duty double nickel plated spun wire baskets, batter plates and stainless steel lids supplied as standard



Single tank fryers with 1 basket								
MODEL	PRICE £	PRICE €	H	W	D	POWER	OIL CAP	WT
DF33	£892	€1026	330	300	632	3kW	7.5L	17
*DF36	£980	€1127	330	300	632	6kW	9L	18
*DF39	£1060	€1220	330	300	632	9kW	9L	18

Alternative half size DF basket

MODEL	PRICE £	PRICE €
A BA96	£97	€113

Single tank fryers with 2 baskets								
MODEL	PRICE £	PRICE €	H	W	D	POWER	OIL CAP	WT
*DF46	£1198	€1379	330	450	632	6kW	15L	22
*DF49	£1238	€1424	330	450	632	9kW	15L	23

Doughnut fryer kit to convert Silverlink 600 counter-top fryers

MODEL	PRICE £	PRICE €	DESCRIPTION
A DC03	£223	€257	For models DF46/49



Twin tank fryers with 2 baskets								
MODEL	PRICE £	PRICE €	H	W	D	POWER	OIL CAP	WT
DF66	£1499	€1725	330	600	632	2x3kW	2x7.5L	26
*DF612	£1789	€2057	330	600	632	2x6kW	2x9L	31
*DF618	£1860	€2139	330	600	632	2x9kW	2x9L	33

Model DF66 supplied with two cables & plugs for easy installation

Single tank fryer with 3 baskets								
MODEL	PRICE £	PRICE €	H	W	D	POWER	OIL CAP	WT
*DF66/ST	£1318	€1516	330	600	632	6kW	20L	28

Gas Counter Top Fryers

- Thermostatic control ensures accurate oil temperature control and consistently perfect results
- Safety features include flame failure device and top temperature cut-out to prevent overheating of oil
- Deep cool zone collects cooking debris - this gives cleaner cooking results and prolongs oil life, saving you money
- Convenient pilot flame operation with piezo ignition
- Heavy duty double nickel plated spun wire baskets, batter plates and stainless steel lids supplied as standard
- For very shallow frying - oil depth approximately 30mm



Single tank fryers with 2 baskets								
MODEL	PRICE £	PRICE €	H	W	D	POWER	OIL CAP	WT
DF4/N	£2156	€2480	415	450	654	11.3kW	8L	43
DF4/P	£2156	€2480	415	450	654	10.5kW	8L	43

Doughnut fryer kit for model DF4

MODEL	PRICE £	PRICE €
A DC01	£223	€257

Key

H = Height (mm)
W = Width (mm)
D = Depth (mm)
WT = Packed Weight in kg

SILVERLINK 600

All gas power ratings are nominal values. All Silverlink 600 counter top units when mounted on optional floor stands or pedestals provide a uniform nominal hob height of 900mm.

Electric Free Standing Fryers

- Front mounted controls ensure safe working practice
- Hinging element with safety cut-out provides easy access to tank for cleaning
- High quality grade 304 stainless steel fryer tanks, fully welded to hobs for added strength and a smooth, easy clean seamless finish
- Thermostatic control with fail-safe top temperature cut out maintains accurate oil temperature and ensures safe operation
- Heavy duty double nickel plated spun wire baskets, batter plates and stainless steel lids supplied as standard



Single tank electric fryer (300mm wide)								
MODEL	PRICE £	PRICE €	H	W	D	POWER	OIL CAP	WT
*J6	£1285	€1479	970 - 980	300	632	6kW	9L	34
*J9	£1417	€1630	970 - 980	300	632	9kW	9L	35

Twin tank electric fryer (600mm wide)								
MODEL	PRICE £	PRICE €	H	W	D	POWER	OIL CAP	WT
*J12	£2227	€2562	970 - 980	600	632	2x6kW	2x9L	54
*J18	£2360	€2715	970 - 980	600	632	2x9kW	2x9L	55

MODEL	PRICE £	PRICE €	DESCRIPTION
A BA96	£97	€113	Alternative half size basket for models J6/J9/J12/J18
S TA28	£115.90	€133.35	2 Gallon Bucket for J Fryers
S ST10	£41.15	€47.30	Strainer for J fryers

Gas Free Standing Fryers

- Thermostatic control ensures accurate oil temperature control and consistently perfect results
- Safety features include flame failure device and top temperature cut-out to prevent overheating of oil
- Deep cool zone collects cooking debris - this gives cleaner cooking results and prolongs oil life, saving you money
- Convenient pilot flame operation with piezo ignition
- Heavy duty double nickel plated spun wire baskets, batter plates and stainless steel lids supplied as standard



Single tank gas fryer (300mm wide)								
MODEL	PRICE £	PRICE €	H	W	D	POWER	OIL CAP	WT
J5/N	£2518	€2896	1060 - 1100	300	690	12kW	12L	52
J5/P	£2518	€2896	1060 - 1100	300	690	11.3kW	12L	52

Twin tank gas fryer (600mm wide)								
MODEL	PRICE £	PRICE €	H	W	D	POWER	OIL CAP	WT
J10/N	£4122	€4741	1060 - 1100	600	690	24kW	2x12L	87
J10/P	£4122	€4741	1060 - 1100	600	690	22.6kW	2x12L	87

Electric Chip Scuttles

- Heated from below
- Removable tank and drain plate for easy cleaning
- Drain plate keeps contents crisp and fresh
- Easy access and better heat retention via hinged lid



Chip scuttle							
MODEL	PRICE £	PRICE €	H	W	D	POWER	WT
CS4	£704	€810	290	450	600	0.5kW	19
CS6	£837	€963	290	600	600	0.75kW	23

Electric Chip Scuttle with Overhead Gantry

- Heated from above and below to maintain even temperature of food
- Overhead heat lamp imparts a warm glow for attractive presentation
- Removable 1/1 GN size chip container for ease of cleaning
- Drain plate keeps contents crisp and fresh



Chip scuttle with overhead gantry							
MODEL	PRICE £	PRICE €	H	W	D	POWER	WT
CS4/G	£1075	€1236	645	450	600	1kW	23

2 YEAR

UK parts and labour warranty

Export parts warranty

on all Lincat products

Lincat

GREEN RANGE

SILVERLINK 600

Electric Eco Salamander

Delivers a 50% reduction in energy consumption.*



- The performance of a Lincat GR3 while delivering a 50% energy saving
- On-demand cooking delivers savings without operational compromise
- Sleep mode to achieve maximum energy savings during quieter periods
- Customisable full power and 50% timers to tailor the grill to your menu and the desired level of energy saving
- 50% power mode keeps the cavity warm for fast recovery
- High-temperature glass covered elements and removable roasting rack and crumb tray, make it effortless to keep clean
- 4 shelf positions to give maximum flexibility for all catering operations
- Plug and play - UK 3 Pin Plug

Delivering



Reduced energy usage



Lincat

Electric eco salamander grill							
MODEL	PRICE £	PRICE €	H	W	D	POWER	WT
**SGE1	£2058	€2470	347	635	373	2.8kW	29

Accessories for SGE1

MODEL	PRICE £	PRICE €	DESCRIPTION	H
A SGE1/FS	£566	€651	Floor stand	1282
A SGE1/BS	£324	€373	Bench stand	402
A SGE1/WS	£215	€248	Wall shelf	N/A
A BR15	£67	€78	Wall brackets	N/A
A ABP03	£345	€397	Single-sided alloy branding plate & drip tray	N/A

2 YEAR

UK parts and labour warranty

Export parts warranty

on all Lincat products

* Compared to the Silverlink GR3

* Please refer to pages L117 to L118 for electricity supply requirements

SILVERLINK 600

All gas power ratings are nominal values.

Electric Salamander Grill

- Even heat distribution - for perfect grilling
- Easy to clean stainless steel interior
- Five grill shelf positions
- Crumb tray and toasting grid included as standard



Electric salamander grill							
MODEL	PRICE £	PRICE €	H	W	D	POWER	WT
GR3	£704	€810	314	600	350	2.8kW	22

Accessories for GR3

MODEL	PRICE £	PRICE €	DESCRIPTION	H
A BR15	£67	€78	Wall brackets	N/A
A ABP03	£345	€397	Single-sided alloy branding plate & drip tray	N/A
A GR3/WS	£215	€248	Wall shelf	N/A
A GR3/BS	£324	€373	Bench stand	350
A GR3/FS	£566	€651	Floor stand	1230

Electric Adjustable Salamander Grills

- Ideal for grilling and gratination
- Smooth action and easy-lift grill hood
- Height markings and an audible timer to ensure consistent results
- Removable fat collection tray and chromed toasting rack included as standard
- 1/1 GN compatible



Electric adjustable salamander grill							
MODEL	PRICE £	PRICE €	H	W	D	POWER	WT
AS3	£2015	€2318	500	600	472	2.8kW	59
*AS4	£2151	€2475	500	600	472	4.5kW	59

MODEL	PRICE £	PRICE €	DESCRIPTION
A BR51	£98	€114	Wall mounting brackets

Gas Salamander Grills

- Powerful ceramic plaque burners
- Vitreous enamelled interior and hood for easy cleaning
- Cool to the touch handles
- Model GR3N/P supplied with crumb tray and toasting grid as standard
- Model GR7N/P supplied with a double sided alloy branding plate and fat collection tray as standard



Gas salamander grill							
MODEL	PRICE £	PRICE €	H	W	D	POWER	WT
GR3/N	£1527	€1757	408	600	423	5kW	24
GR3/P	£1527	€1757	408	600	423	5kW	24

Accessories for GR3/N and GR3/P

MODEL	PRICE £	PRICE €	DESCRIPTION	H
A ABP03	£345	€397	Single-sided alloy branding plate & drip tray	N/A
A GR3/WS	£215	€248	Wall shelf	N/A
A GR3/BS	£324	€373	Bench stand	350
A GR3/FS	£566	€651	Floor stand	1230



Gas salamander grill							
MODEL	PRICE £	PRICE €	H	W	D	POWER	WT
GR7/N	£2244	€2581	405	750	423	6.5kW	44
GR7/P	£2244	€2581	405	750	423	6.5kW	44

Accessories for GR7/N and GR7/P

MODEL	PRICE £	PRICE €	DESCRIPTION	H
A BR39	£314	€361	Additional double-sided alloy branding plate	N/A
A GR7/WS	£255	€294	Wall shelf	N/A
A GR7/BS	£367	€423	Bench stand	350

SILVERLINK 600

All gas power ratings are nominal values. All Silverlink 600 counter top units when mounted on optional floor stands or pedestals provide a uniform nominal hob height of 900mm.

Electric Griddles

- Solid 12mm thick machined steel plate ensures even heat distribution and excellent heat retention
- Fully-welded plates eliminate dirt traps
- Thermostatically controlled for consistent performance
- Models with extra power (/E) available



Machine steel plate griddles							
MODEL	PRICE £	PRICE €	H	W	D	POWER	WT
GS3	£792	€911	330	300	600	2kW	24
GS3/E	£884	€1017	330	300	600	2.5kW	25
GS4	£932	€1072	330	450	600	2.7kW	42
GS4/E	£1013	€1165	330	450	600	3.7kW	43
GS6	£1066	€1226	330	600	600	3kW	51
*GS6S	£1121	€1290	330	600	620	4.5kW	53
*GS6/T	£1169	€1345	330	600	620	4kW	55
*GS6/T/E	£1232	€1418	330	600	620	5.6kW	55
*GS7	£1285	€1479	330	750	620	6kW	69
*GS7/E	£1342	€1543	330	750	620	7kW	67
*GS9	£1538	€1769	330	900	620	8.6kW	81

‡ Dual zone

Hard chrome plate griddles							
MODEL	PRICE £	PRICE €	H	W	D	POWER	WT
GS3/C	£1789	€2057	330	300	600	2kW	24
GS4/C	£2086	€2399	330	450	600	2.7kW	43
GS6/C	£2400	€2761	330	600	600	3kW	56
*GS6C/T	£2622	€3015	330	600	620	4kW	54
*GS7/C	£2873	€3305	330	750	620	6kW	68

‡ Dual zone

Half-ribbed griddles							
MODEL	PRICE £	PRICE €	H	W	D	POWER	WT
*GS6/TR	£1332	€1532	330	600	620	4kW	53
*GS6/TR/E	£1401	€1611	330	600	620	5.6kW	53
*GS7/R	£1459	€1678	330	750	620	6kW	69

‡ Dual zone

Fully-ribbed griddle							
MODEL	PRICE £	PRICE €	H	W	D	POWER	WT
*GS6/TFR	£1559	€1793	330	600	620	4kW	54

‡ Dual zone

Griddle splashbacks

MODEL	PRICE £	PRICE €	DESCRIPTION
A SB3	£116	€133	For GS3 griddles
A SB4	£129	€149	For GS4 griddles
A SB6	£131	€152	For GS6 griddles
A SB7	£142	€163	For GS7 griddles
A SB9	£146	€168	For GS9 griddles

Note: All splashbacks are 115mm high

Key

H = Height (mm)
W = Width (mm)
D = Depth (mm)
WT = Packed Weight in kg

Gas Griddles

- Solid 12mm thick machined steel plate ensures even heat distribution and excellent heat retention
- Fully-welded plates eliminate dirt traps
- High and low heat settings for controlled cooking
- Piezo ignition and flame failure device for convenient and safe operation



Machine steel plate griddles							
MODEL	PRICE £	PRICE €	H	W	D	POWER	WT
GS4/N	£1568	€1804	415	450	650	5.4kW	49
GS4/P	£1568	€1804	415	450	650	5.5kW	49
‡GS7/N	£2227	€2562	415	750	650	7.5kW	70
‡GS7/P	£2227	€2562	415	750	650	8kW	70

‡ Dual zone

Griddle splashbacks

MODEL	PRICE £	PRICE €	DESCRIPTION
A SB4	£129	€149	For GS4 griddles
A SB7	£142	€163	For GS7 griddles

Half-ribbed griddles							
MODEL	PRICE £	PRICE €	H	W	D	POWER	WT
‡GS7R/N	£2386	€2744	415	750	650	7.5kW	70
‡GS7R/P	£2386	€2744	415	750	650	8kW	70

‡ Dual zone

Product Codes

/N = natural gas /P = propane gas Btu/hr = kW x 3412

SILVERLINK 600

All gas power ratings are nominal values. All Silverlink 600 counter top units when mounted on optional floor stands or pedestals provide a uniform nominal hob height of 900mm.

Gas Chargrills

- Heat transfer radiants eliminate the need for messy lava rock
- Removable branding grids, heat transfer radiants, fat collection drawer and debris collection tray for easy cleaning
- Adjustable cooking grid and variable heat control for maximum controllability
- Heat retaining cooking grids produces clean, sharp branding marks to enhance food presentation
- Twin heat zones



MODEL	PRICE £	PRICE €	H	W	D	POWER	WT
CG4/N	£1689	€1942	414	450	652	16.4kW	36
CG4/P	£1689	€1942	414	450	652	17.6kW	36

MODEL	PRICE £	PRICE €	H	W	D	POWER	WT
CG6/N	£2202	€2532	414	600	652	16.4kW	48
CG6/P	£2202	€2532	414	600	652	17.6kW	48

Electric Chargrills

- High heat retention of cast iron grids means there is no waiting for the grill to recover to cooking temperature
- Hinging interlocked elements and integral water bath make cleaning easier
- Integral splashguard with water funnel enables refilling of tank without cooling the cooking grid
- Water bath provides humidity, keeping food succulent and reducing shrinkage
- High temperature safety cut out for protection if water bath runs dry
- ECG9/WT features water connection for ease of use



MODEL	PRICE £	PRICE €	H	W	D	POWER	WT
*ECG6	£2045	€2352	385	600	620	8kW	41
*ECG9	£3314	€3811	385	900	620	13.3kW	67
*ECG9/WT	£3854	€4433	385	900	620	13.3kW	67

Electric Pasta Boilers

- Front mounted controls ensure safe working practice
- Hinging element with safety cut out provides easy access to tank for cleaning
- Front drain taps for fast, easy drainage of water
- Thermostatic control maintains accurate water temperature
- Corrosion-resistant stainless steel tanks and elements for long service life



MODEL	PRICE £	PRICE €	H	W	D	POWER	WT
PB33	£1002	€1152	330	300	600	3kW	15

Price does not include basket

MODEL	PRICE £	PRICE €	H	W	D	POWER	WT
PB66	£1700	€1955	330	600	600	2x3kW	27

Price does not include basket
Supplied with two cables & plugs for easy installation

Pasta Baskets

MODEL	PRICE £	PRICE €	W	PB33 NO. REQUIRED
A BA112	£184	€211	202	1
A BA114	£175	€202	101	2
A BA115+ BB116	£146 (each)	€168 (each)	101	2 of each

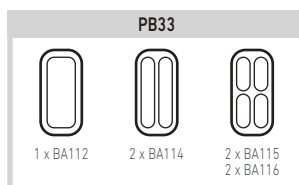

Pasta Baskets

MODEL	PRICE £	PRICE €	W	PB33 NO. REQUIRED
A BA112	£184	€211	202	1
A BA114	£175	€202	101	2
A BA115+ BB116	£146 (each)	€168 (each)	101	4 of each

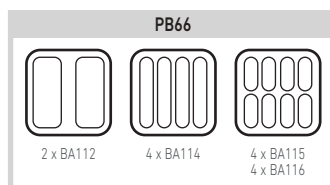

Key

H = Height (mm)
W = Width (mm)
D = Depth (mm)
WT = Packed Weight in kg

Product Codes

/N = natural gas /P = propane gas Btu/hr = kW x 3412

SILVERLINK 600

All gas power ratings are nominal values. All Silverlink 600 counter top units when mounted on optional floor stands or pedestals provide a uniform nominal hob height of 900mm.

Electric Bains Marie (Round Pots)

- Perfect for safely holding sauces, gravy and pre-cooked foods for up to two hours at serving temperature
- Adjustable heat control
- 8 pint (4.5 litre) stainless steel pots included



Dry heat bains marie								
MODEL	PRICE £	PRICE €	H	W	D	POWER	WT	
BS3	£578	€666	325	300	600	0.5kW	15	

Dry heat bains marie								
MODEL	PRICE £	PRICE €	H	W	D	POWER	WT	
BS4	£744	€856	325	450	600	0.75kW	18	

Dry heat bains marie								
MODEL	PRICE £	PRICE €	H	W	D	POWER	WT	
BS7	£903	€1039	325	750	600	1kW	28	

Wet heat bains marie								
MODEL	PRICE £	PRICE €	H	W	D	POWER	WT	
BS3W	£735	€845	325	300	600	1kW	16	

Wet heat bains marie								
MODEL	PRICE £	PRICE €	H	W	D	POWER	WT	
BS4W	£884	€1017	325	450	600	1kW	19	

Wet heat bains marie								
MODEL	PRICE £	PRICE €	H	W	D	POWER	WT	
BS7W	£1128	€1298	325	750	600	2kW	29	

Key
 H = Height (mm)
 W = Width (mm)
 D = Depth (mm)
 WT = Packed Weight in kg

Electric Bains Marie (Gastronorm Dishes)

- Perfect for safely holding sauces, gravy and pre-cooked foods for up to two hours at serving temperature
- Adjustable heat control
- Available as base units or with a choice of 150mm deep gastronorm dishes



Dry heat bains marie								
MODEL	PRICE £	PRICE €	H	W	D	POWER	WT	
BM3	£532	€612	290	300	600	0.5kW	13	
BM3A	£662	€762	290	300	600	0.5kW	15	

Dry heat bains marie								
MODEL	PRICE £	PRICE €	H	W	D	POWER	WT	
BM4	£641	€738	290	450	600	0.75kW	15	
BM4A	£767	€882	290	450	600	0.75kW	18	
BM4B	£767	€882	290	450	600	0.75kW	18	
BM4C	£735	€845	290	450	600	0.75kW	18	
BM4D	£767	€882	290	450	600	0.75kW	18	
BM4E	£767	€882	290	450	600	0.75kW	18	

Dry heat bains marie								
MODEL	PRICE £	PRICE €	H	W	D	POWER	WT	
BM6	£712	€819	290	600	600	0.75kW	17	
BM6A	£903	€1039	290	600	600	0.75kW	22	
BM6B	£862	€991	290	600	600	0.75kW	22	
BM6C	£940	€1081	290	600	600	0.75kW	22	

Dry heat bains marie								
MODEL	PRICE £	PRICE €	H	W	D	POWER	WT	
BM7	£869	€1000	290	750	600	1kW	23	
BM7A	£1121	€1290	290	750	600	1kW	30	
BM7B	£1113	€1280	290	750	600	1kW	29	
BM7C	£1175	€1351	290	750	600	1kW	30	
BM7X	£862	€991	290	750	600	1kW	22	
BM7XA	£1013	€1165	290	750	600	1kW	28	
BM7XB	£1060	€1220	290	750	600	1kW	27	
BM7XC	£1121	€1290	290	750	600	1kW	28	



Wet heat bains marie								
MODEL	PRICE £	PRICE €	H	W	D	POWER	WT	
BM3W	£665	€765	290	300	600	1kW	14	
BM3AW	£815	€938	290	300	600	1kW	15	

Wet heat bains marie								
MODEL	PRICE £	PRICE €	H	W	D	POWER	WT	
BM4W	£786	€905	290	450	600	1kW	16	
BM4AW	£916	€1054	290	450	600	1kW	19	
BM4BW	£924	€1063	290	450	600	1kW	19	
BM4CW	£884	€1017	290	450	600	1kW	19	
BM4DW	£916	€1054	290	450	600	1kW	19	
BM4EW	£924	€1063	290	450	600	1kW	19	

Wet heat bains marie								
MODEL	PRICE £	PRICE €	H	W	D	POWER	WT	
BM6W	£862	€991	290	600	600	2kW	19	
BM6AW	£1060	€1220	290	600	600	2kW	24	
BM6BW	£1026	€1181	290	600	600	2kW	24	
BM6CW	£1098	€1263	290	600	600	2kW	24	

Wet heat bains marie								
MODEL	PRICE £	PRICE €	H	W	D	POWER	WT	
BM7W	£1013	€1165	290	750	600	2kW	23	
BM7AW	£1301	€1497	290	750	600	2kW	30	
BM7BW	£1259	€1449	290	750	600	2kW	29	
BM7CW	£1356	€1560	290	750	600	2kW	29	
BM7XW	£1019	€1173	290	750	600	2kW	22	
BM7XAW	£1185	€1363	290	750	600	2kW	28	
BM7XBW	£1223	€1407	290	750	600	2kW	28	
BM7XCW	£1259	€1449	290	750	600	2kW	28	

Bains Marie Gastronorm configurations

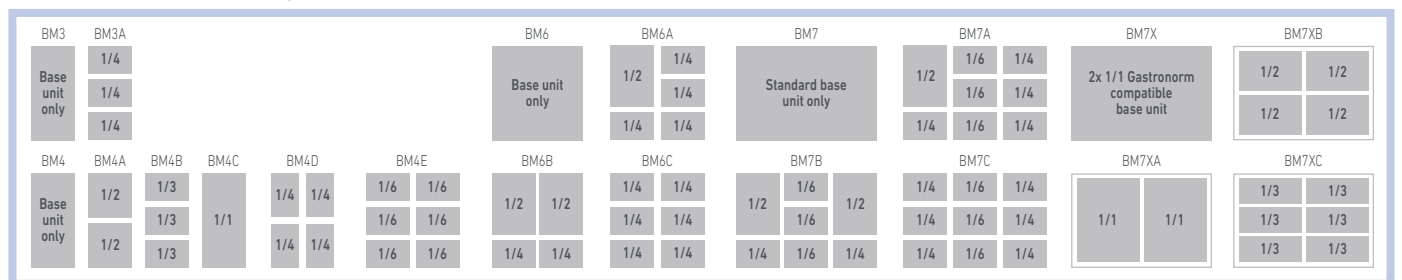

SILVERLINK 600

All Silverlink 600 counter top units when mounted on optional floor stands or pedestals provide a uniform nominal hob height of 900mm.

Work Tops

- Designed to match Silverlink 600 appliances
- Provides useful work space
- Models with drawers provide handy additional storage space



Work tops						
MODEL	PRICE £	PRICE €	H	W	D	WT
WT3	£224	€258	290	300	600	8
WT4	£249	€287	290	450	600	10
WT6	£260	€299	290	600	600	13

Work tops with drawers						
MODEL	PRICE £	PRICE €	H	W	D	WT
WT3D	£412	€474	290	300	600	12
WT4D	£425	€489	290	450	600	14
WT6D	£474	€545	290	600	600	18

Stands

- Designed to support Silverlink 600 electric or gas counter-top units
- Sturdy, robust stainless steel construction with fully welded joints
- Multiple counter-top units may be supported on a single base
- Adjustable legs provide stability on uneven floors
- No dirt traps means quick, easy cleaning
- Stands SLS6V and SLS7V for use with V6 and V7 series ovens



Stands						
MODEL	PRICE £	PRICE €	H	W	D	WT
A SLS3	£444	€511	650 - 662	300	567	14
A SLS4	£466	€536	650 - 662	450	567	16
A SLS6	£530	€610	650 - 662	600	567	16
A SLS7	£625	€718	650 - 662	750	567	19
A SLS9	£714	€821	650 - 662	900	567	29

Stands for V Ovens						
MODEL	PRICE £	PRICE €	H	W	D	WT
A SLS6V	£540	€622	650 - 662	600	567	17
A SLS7V	£626	€720	650 - 662	750	567	19

Suitable for use with gas products

Pedestals

- Designed to support Silverlink 600 electric counter-top units
- Adjustable shelf provides flexibility
- Adjustable for perfect alignment on uneven floors
- Heated models feature thermostatic control - ideal as plate warmers
- CC, HC and HCL models feature doors which fit left or right handed for flexibility in kitchen planning



Ambient open-top pedestals without doors						
MODEL	PRICE £	PRICE €	H	W	D	WT
A CN3	£404	€465	650 - 660	300	600	16
A CN4	£420	€484	650 - 660	450	600	20
A CN6	£479	€552	650 - 660	600	600	24
A CN7	£540	€622	650 - 660	750	600	31

Additional shelves for pedestals			
MODEL	PRICE £	PRICE €	FOR UNIT WIDTHS
A PSH3	£49	€57	300mm
A PSH4	£58	€67	450mm
A PSH6	£66	€77	600mm
A PSH7	£77	€89	750mm

Ambient open-top pedestals with doors						
MODEL	PRICE £	PRICE €	H	W	D	WT
A CC3	£507	€583	650 - 660	300	600	18
A CC4	£522	€600	650 - 660	450	600	23
A CC6	£579	€667	650 - 660	600	600	29
A CC7	£667	€768	650 - 660	750	600	37

Additional shelves for pedestals			
MODEL	PRICE £	PRICE €	FOR UNIT WIDTHS
A PSH3	£49	€57	300mm
A PSH4	£58	€67	450mm
A PSH6	£66	€77	600mm
A PSH7	£77	€89	750mm

Not suitable for use with gas products

Not suitable for use with gas products



2 **YEAR** UK parts and labour warranty | Export parts warranty on all Lincat products



Heated open-top pedestals with doors							
MODEL	PRICE £	PRICE €	H	W	D	POWER	WT
A HC3	£640	€737	650 - 660	300	600	0.25kW	17
A HC4	£674	€776	650 - 660	450	600	0.5kW	25
A HC6	£700	€805	650 - 660	600	600	0.5kW	32
A HC7	£799	€919	650 - 660	750	600	0.5kW	37

Not suitable for use with gas products

Heated pedestals with legs and doors							
MODEL	PRICE £	PRICE €	H	W	D	POWER	WT
A HCL3	£707	€813	650 - 668	300	600	0.25kW	24
A HCL4	£738	€849	650 - 668	450	600	0.5kW	27
A HCL6	£799	€919	650 - 668	600	600	0.5kW	34
A HCL7	£848	€976	650 - 668	750	600	0.75kW	46
A HCL9	£931	€1071	650 - 668	900	600	1kW	53

Not suitable for use with gas products

Additional shelves for pedestals			
MODEL	PRICE £	PRICE €	FOR UNIT WIDTHS
A PSH3	£49	€57	300mm
A PSH4	£58	€67	450mm
A PSH6	£66	€77	600mm
A PSH7	£77	€89	750mm

Additional shelves for pedestals			
MODEL	PRICE £	PRICE €	FOR UNIT WIDTHS
A PSH3	£49	€57	300mm
A PSH4	£58	€67	450mm
A PSH6	£66	€77	600mm
A PSH7	£77	€89	750mm
A PSH9	£94	€109	900mm



LYNX400



Produce perfect plates of food in no time with the Lynx 400 plug in and play series.

The electric Lynx 400 series is designed to be portable. The units are compact, but what they lack in size they more than make up for in quality.

There's no complicated set up process with the Lynx 400 series. They're ready to go immediately, which means you only have to think about the range of delicious dishes you're going to create.

Made in the UK, the series is sturdy and built to last. Whatever the product - fryers, griddles, pasta boilers or pizza ovens - you can rely on them not to let you down.

Ideally suited for...

The products within the Lynx 400 series are highly portable and compact, making them perfect for cafés and pubs as well as event catering.

The Lynx 400 range is full of compact, quality products that are designed to plug in and play.



Cafés

The series is great if you're looking to offer customers light meals and snacks, such as toasted sandwiches and fries.



Pubs

Space saving, the range is perfect for crispy chips, delicious pasta and perfect pizzas, among other great dishes.

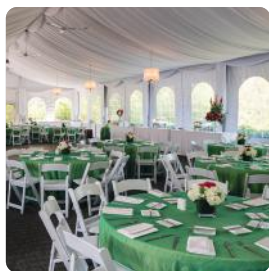

Events

If you cater at events, you'll love the portability of the Lynx 400 series. What's more, the products are designed to plug in and play, so there's no set up times to worry about.

Benefits at a glance

- Typically 400mm deep
- Plug in and play
- Portable
- Robust
- Quality - made in the UK
- Easy to clean



Convection Ovens

- Compact footprint, starting at 40.5cm wide there is a convection oven for even the smallest of outlets
- Direct placement of gastronorms and trays on racks maximises oven space
- LCOS and LCOT supplied with 2 shelves, LCOXL supplied with 3 shelves
- Powerful fan assisted cooking for uniform cooking and consistent results
- Powerful 2.5kW oven for rapid heat up
- Simple dial controls with 60 minute timer
- Side opening door with double glass viewing panel delivering energy efficiency and safe cool touch door
- 13 Amp plug for easy plug and play operation
- User replaceable inner door glass, light bulb and door seal so maintenance is fuss free
- 2 years on site parts and labour warranty, in the event of an issue we will send an engineer to site, minimising downtime and inconvenience for the end user



LCO Slim (LCOS)

Accommodates 4 x 1/2 gastronorms

- Heat up time 0 - 200°C - 7 mins, 50 secs
- Output from 24 frozen croissants per hour
- Output from 30 demi baguettes per hour



LCO Tall (LCOT)

Accommodates 4 x 2/3 gastronorms

- Heat up time 0 - 200°C - 10 mins, 40 secs
- Output from 32 frozen croissants per hour
- Output from 48 demi baguettes per hour



LCO XL (LCOXL)

Accommodates 4 x 1/1 gastronorms

- Heat up time 0 - 200°C - 15 min, 45 secs
- Output from 48 frozen croissants per hour
- Output from 60 demi baguettes per hour

Convection Ovens							
MODEL	PRICE £	PRICE €	H	W	D	POWER	WT
LCOS	£1054	€1214	520	405	570	2.5kW	34
LCOT	£1084	€1248	520	495	570	2.5kW	38
LCOXL	£1404	€1615	605	670	570	2.5kW	60

	MODEL	PRICE £	PRICE €	DESCRIPTION
A	SH140	£37.65	€43.35	Additional LCOS Shelf
A	SH139	£40.25	€46.35	Additional LCOT Shelf
A	SH141	£62.25	€71.60	Additional LCOXL Shelf



- Fan assisted for uniform heat and consistent cooking results
- Double-glazed glass door and internal light for safe, energy-efficient operation
- Two removable chromed rod shelves
- Stainless steel interior for easy cleaning
- User-replaceable inner door glass, light bulb and door seal - avoids costly service calls for routine maintenance

Counter-top convection oven							
MODEL	PRICE £	PRICE €	H	W	D	POWER	WT
LCO	£1097	€1262	371	555	488	2.5kW	30

2 YEAR

UK parts and labour warranty
Export parts warranty
on all Lincat products



Pizza Deck Oven

- Compact footprint, only 53cm wide
- Small unit, large capacity, deliver up to 14" pizzas
- Firebrick base to produce high-quality, crisp pizzas with authentic taste
- Make a style statement, available in black, red and stainless steel
- Temperature display gauge for easy monitoring
- Independently controlled top and bottom elements
- 18 minute timer
- Maximum temperature 400°C

- Easy plug and play operation - 13A plug
- Easy clean stainless steel design
- Heat up time 0 - 400°C - 39 minutes
- Cook time 14" pizza - 2 minutes, 30 seconds*
- Output per hour - 24 x 14" pizza*

*Based on a fresh dough pizza. Total cooking time: 2 minutes 50 seconds, with 30 seconds allowed for loading and unloading. Temperature of 350°C.



LDPO/B



LDPO/S



LDPO/R

Pizza deck ovens							
MODEL	PRICE £	PRICE €	H	W	D	POWER	WT
LDPO/S	£1221	€1404	300	530	558	2.2kW	41
LDPO/B	£1221	€1404	300	530	558	2.2kW	41
LDPO/R	£1221	€1404	300	530	558	2.2kW	41

MODEL	PRICE £	PRICE €	DESCRIPTION
A LT01	£68	€79	Loading Tool

Griddles

- Compact, low-profile design
- Excellent even heat allows you to use the whole plate
- One piece cast iron griddle plate with integral splashguard
- Fast heat up from cold
- Thermostatic control for accurate repeatable results



Griddles							
MODEL	PRICE £	PRICE €	H	W	D	POWER	WT
LGR	£541	€621	163	315	400	2kW	13
LGR2	£682	€784	163	615	400	3kW	23

Key

- H = Height (mm)
- W = Width (mm)
- D = Depth (mm)
- WT = Packed Weight in kg

2 YEAR UK parts and labour warranty | Export parts warranty
on all Lincat products



Key

- H = Height (mm)
- W = Width (mm)
- D = Depth (mm)
- WT = Packed Weight in kg

Contact / Panini Grills

- Enamelled cast iron plates give excellent heat retention and are easy to clean
- Fast heat up from cold
- Thermostatic control for accurate repeatable results
- Compact, low-profile design
- Twin models supplied with two cables and plugs for easy installation



Single contact grill									
MODEL	PRICE £	PRICE €	DESCRIPTION	H	W	D	POWER	WT	
LCG	£855	€984	Flat upper & lower plates	182	293	400	2.25kW	21	
LRG	£855	€984	Ribbed upper & flat lower plates	182	293	400	2.25kW	22	
LPG	£855	€984	Ribbed upper & lower plates	182	293	400	2.25kW	23	

Omelette spacer

MODEL	PRICE £	PRICE €
A OS2	£64	€74

Twin contact grill									
MODEL	PRICE £	PRICE €	DESCRIPTION	H	W	D	POWER	WT	
LCG2	£1491	€1715	Flat upper & lower plates	182	623	400	4.5kW	41	
LRG2	£1491	€1715	Ribbed upper & flat lower plates	182	623	400	4.5kW	43	
LPG2	£1491	€1715	Ribbed upper & lower plates	182	623	400	4.5kW	45	

Omelette spacer

MODEL	PRICE £	PRICE €
A OS2	£64	€74

High Powered Contact / Panini Grills

- Large capacity
- Ideal for front-of-house use
- Seals in juices and flavour for succulent results - and minimal shrinkage
- Cast aluminium plates and mica heating elements for extremely even heat and precise control
- PTFE base non-stick coating for ease of cleaning



Heavy duty contact grill									
MODEL	PRICE £	PRICE €	DESCRIPTION	H	W	D	POWER	WT	
GG1	£1733	€1994	Flat upper & lower plates	276	395	356	3kW	25	
GG1P	£1733	€1994	Ribbed upper & flat lower plates	276	395	356	3kW	25	
GG1R	£1733	€1994	Ribbed upper & lower plates	276	395	356	3kW	25	

Sandwich spacer

MODEL	PRICE £	PRICE €
A SS1	£49	€56

Omelette spacer

MODEL	PRICE £	PRICE €
A OS1	£59	€69

2 YEAR

UK parts and labour warranty
Export parts warranty
on all Lincat products

Salamander Grill

- Ideal for grilling a wide variety of food products, including meat
- Powerful and robust tubular sheathed element
- Even heat provides maximum output
- Supplied with a toasting rack and grill pan - with stay-cool handles
- Durable vitreous enamelled fascia for easy cleaning



MODEL	PRICE £	PRICE €	H	W	D	POWER	WT
LGT	£576	€662	322	553	320	3kW	17

Brackets for LGT

MODEL	PRICE £	PRICE €
A BR15	£67	€78

Infra-red Grills

- Rapid heat up - save energy by switching on just when you need to use it
- Durable vitreous enamel fascia for easy cleaning
- Accurate electrical timer for precise cooking control
- Six clip-in, user-changeable quartz infra-red elements give a warm attractive glow (great for front of house situations)
- Model LPC offers variable heat control of lower elements
- Model LSC offers variable heat control of both upper and lower elements



MODEL	PRICE £	PRICE €	H	W	D	POWER	WT
LPC	£632	€727	325	552	302	3kW	14

MODEL	PRICE £	PRICE €	DESCRIPTION
A BR15	£67	€78	Wall brackets
C TO10	£126.15	€146	Toasting bags (Pack of 1000)

MODEL	PRICE £	PRICE €	H	W	D	POWER	WT
LSC	£653	€751	325	552	302	3kW	18

MODEL	PRICE £	PRICE €	DESCRIPTION
A BR15	£67	€78	Wall brackets
C TO10	£127	€145.05	Toasting bags (Pack of 1000)

Fryers

- Removable control head and elements for easy cleaning
- Thermostatic control with fail-safe top temperature cut-out
- Removable stainless steel tank and batter plate for easy cleaning
- Batter plate, stainless steel lid and nickel plated basket supplied as standard
- Twin tank LDF2 model supplied with two cables and plugs for easy installation



MODEL	PRICE £	PRICE €	H	W	D	POWER	OIL CAP	WT
LSF	£452	€520	315	184	417	2.5kW	2.5L	8

MODEL	PRICE £	PRICE €	H	W	D	POWER	OIL CAP	WT
LDF	£469	€540	315	270	417	3kW	4L	13

MODEL	PRICE £	PRICE €	H	W	D	POWER	OIL CAP	WT
LDF2	£899	€1034	315	540	417	2x3kW	2x4L	18

MODEL	PRICE £	PRICE €	H	W	D	POWER	OIL CAP	WT
LFF	£616	€708	315	360	417	3kW	5L	12

LYNX⁴⁰⁰

Chip Scuttle

- Holds chips and other cooked products at perfect serving temperature
- Perforated drain plate gives easy access and helps to keep chips crisp
- Easy to clean - removable drain plate and interior
- Adjustable temperature control



Chip Scuttle							
MODEL	PRICE £	PRICE €	H	W	D	POWER	WT
LCS	£426	€490	232	285	400	0.25kW	9

Boiling Tops

- Compact, low-profile design
- 180 mm / 7" sealed hotplates for easy cleaning
- Variable heat control
- Automatic power reduction, if pan boils dry or is removed - prolonging hotplate life



Single plate boiling top							
MODEL	PRICE £	PRICE €	H	W	D	POWER	WT
LBR	£323	€372	120	285	400	2kW	7

Twin plate boiling top							
MODEL	PRICE £	PRICE €	H	W	D	POWER	WT
LBR2	£452	€520	120	565	400	3kW	12

Pasta Boiler

- Lift out control panel and element for easy cleaning
- Corrosion-resistant elements for long service life
- High quality grade 304 stainless steel tanks and basket support plate
- Interlock for added safety (the power is cut if the control head is not in place)
- Boil dry protection for prolonged element life
- Supplied with a perforated basket as standard (optional half size inserts available)



Pasta boiler							
MODEL	PRICE £	PRICE €	H	W	D	POWER	WT
LPB	£701	€807	315	270	417	3kW	10

Accessories for LPB

MODEL	PRICE £	PRICE €	DESCRIPTION
A BA158	£69	€80	Half size basket insert (requires two per basket)

Key

- H = Height (mm)
- W = Width (mm)
- D = Depth (mm)
- WT = Packed Weight in kg

Key

H = Height (mm)
W = Width (mm)
D = Depth (mm)
WT = Packed Weight in kg

LYNX⁴⁰⁰

Bains Marie (Gastronorm Dishes)

- Perfect for holding sauces, soups, gravy and pre-cooked foods for up to 2 hours at serving temperature
- Adjustable heat control gives added versatility
- Wet heat models may be operated either wet or dry
- Supplied with 100mm deep stainless steel 1/4 GN "Super Pan II" containers with lids



⚡ Bain Marie - 2 x 1/4 GN (dry heat)								
MODEL	PRICE £	PRICE €	H	W	D	POWER	WT	
LBM	£405	€466	196	285	400	0.25kW	8	

⚡ Bain Marie - 4 x 1/4 GN (dry heat)								
MODEL	PRICE £	PRICE €	H	W	D	POWER	WT	
LBM2	£599	€690	196	565	400	0.5kW	15	

⚡ Bain Marie - 6 x 1/4 GN (dry heat)								
MODEL	PRICE £	PRICE €	H	W	D	POWER	WT	
LBM3	£698	€804	196	850	400	0.75kW	22	

⚡ Bain Marie - 2 x 1/4 GN (wet heat)								
MODEL	PRICE £	PRICE €	H	W	D	POWER	WT	
LBMW	£469	€540	196	285	400	0.25kW	10	

⚡ Bain Marie - 4 x 1/4 GN (wet heat)								
MODEL	PRICE £	PRICE €	H	W	D	POWER	WT	
LBM2W	£689	€792	196	565	400	0.5kW	17	

⚡ Bain Marie - 6 x 1/4 GN (wet heat)								
MODEL	PRICE £	PRICE €	H	W	D	POWER	WT	
LBM3W	£844	€971	196	850	400	0.75kW	26	

Bains Marie (Round Pots)

- Perfect for holding sauces, soups, gravy and pre-cooked foods for up to 2 hours at serving temperature
- Adjustable heat control gives added versatility
- Wet heat models may be operated either wet or dry
- 8 pint (4.5 litres) stainless steel round pots and lids included as standard



⚡ Bain Marie - 1 round pot (dry heat)								
MODEL	PRICE £	PRICE €	H	W	D	POWER	WT	
LRB	£329	€378	240	285	400	0.25kW	8	

⚡ Bain Marie - 2 round pots (dry heat)								
MODEL	PRICE £	PRICE €	H	W	D	POWER	WT	
LRB2	£518	€596	240	565	400	0.5kW	14	

⚡ Bain Marie - 3 round pots (dry heat)								
MODEL	PRICE £	PRICE €	H	W	D	POWER	WT	
LRB3	£616	€708	240	850	400	0.75kW	21	

⚡ Bain Marie - 1 round pot (wet heat)								
MODEL	PRICE £	PRICE €	H	W	D	POWER	WT	
LRBW	£396	€455	240	285	400	0.25kW	9	

⚡ Bain Marie - 2 round pots (wet heat)								
MODEL	PRICE £	PRICE €	H	W	D	POWER	WT	
LRB2W	£608	€699	240	565	400	0.5kW	17	

⚡ Bain Marie - 3 round pots (wet heat)								
MODEL	PRICE £	PRICE €	H	W	D	POWER	WT	
LRB3W	£755	€869	240	850	400	0.75kW	23	

2 YEAR

UK parts and labour warranty
Export parts warranty
on all Lincat products

Lincat

lincat.co.uk

2026



Lincat Specialist



Whatever your kitchen needs, you'll find a solution with the Lincat range of specialist, built-for-purpose products.

The Lincat range of products are built for specific applications, so if you have a particular need for your kitchen, you're sure to find the right product for you.

The range includes pizza ovens, convection ovens, toasters and induction hobs, among others. Each product within the range is made with care, delivering great results time after time.

Ideally suited for...

Given the variety of products within the Lincat range, there are a range of establishments that could benefit from their specific functions, including:



Cafés

Are you looking for products to produce sumptuous snacks for your café? The Lincat range includes pizza ovens to recreate the authentic Italian taste.



Bakery

Looking to produce delicious evenly baked breads and cakes. You'll find the the perfect solution with the Lincat convection oven range.

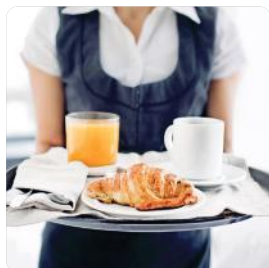

Hotels

The Lincat range offers conveyor toasters capable of making over 300 slices of perfectly crunchy toast, through to food warming drawers to keep your dishes at the optimum temperature.



Events

The Lincat Table Top Induction Hobs feature a lightweight and portable plug in design to offer the ultimate versatility.

Looking for a specific solution for your kitchen? You're sure to find it with the Lincat range of built-for-purpose products.

Benefits at a glance

- Specific functionality
- Designed-for-purpose
- Front and back of house applications

Convection Ovens

- Efficient air circulation, with twin fans for fast and even cooking
- Robust stainless steel construction
- Cook and hold facility
- Accepts 1/1 GN containers for convenient operation
- Water injection facility gives a professional finish to breads and pastries
- Double-glazed door for energy efficiency
- Stackable to make best use of limited space
- Higher powered model ECO9 has larger oven and offers faster heat up and recovery times



Counter-top convection oven							
MODEL	PRICE £	PRICE €	H	W	D	POWER	WT
ECO8	£2917	€3355	575	787	644	3kW	84
Internal dimensions			430	600	504		

(765mm deep with water supply connected)

Floor stand for model ECO8

MODEL	PRICE £	PRICE €	H	W	D
A ECO8/FS	£973	€1119	930	787	589

Holds 12 x 1/1GN containers

Low level floor stand for use with ECO8

MODEL	PRICE £	PRICE €	H	W	D
A ECO8/LFS	£744	€856	410	787	589

Holds 4 x 1/1GN containers

Kit for stacking 2 x ECO8

MODEL	PRICE £	PRICE €	DESCRIPTION	H
A ECO8/SK	£332	€381	ECO8 Stacking kit	60

2

YEAR

UK parts and labour warranty

Export parts warranty

on all Lincat products

Counter-top convection oven							
MODEL	PRICE £	PRICE €	H	W	D	POWER	WT
*ECO9	£4639	€5336	652	766	840	7.5kW	101
Internal dimensions			510	480	700		

(845mm deep with water supply connected)

Floor stand for model ECO9

MODEL	PRICE £	PRICE €	H	W	D
A ECO9/FS	£1016	€1168	930	766	757

Holds 12 x 1/1GN containers

Low level floor stand for use with ECO9

MODEL	PRICE £	PRICE €	H	W	D
A ECO9/LFS	£875	€1007	410	766	757

Holds 4 x 1/1GN containers

Kit for stacking 2 x ECO9

MODEL	PRICE £	PRICE €	DESCRIPTION	H
A ECO9/SK	£366	€421	ECO9 Stacking kit	60

Induction Hobs

- Single and twin cooking zones for high output
- High efficiency - delivers almost twice the cooking power of a similarly rated gas hob
- Functional and attractive profile is perfect for front of house theatre style cooking
- 6mm thick high impact resistant glass ceramic surface to withstand hard knocks



Lincat

Induction hob								
MODEL	PRICE £	PRICE €	H	W	D	ZONES	POWER	WT
IH3	£1585	€1823	115	400	654	1	2.4kW	15
IH21	£1602	€1842	115	350	654	2	3kW	15
IH42	£2875	€3307	115	600	654	4	2 x 3kW	28

Key

H = Height (mm)
 W = Width (mm)
 D = Depth (mm)
 WT = Packed Weight in kg

Food Warming Drawers

- Pre-set thermostat keeps food at constant temperature
- Humidity facility keeps food contents moist for extended periods
- Full insulation ensures energy efficiency and safe, cool surfaces and controls
- Large removable drawers for ease of cleaning
- Smooth action stainless steel runners



Food warming drawers							
MODEL	PRICE £	PRICE €	H	W	D	POWER	WT
FWDG	£2569	€2955	490	620	578	1.5kW	63

Premium Range Pizza Ovens

- Thermostatic control up to 480°C with temperature display gauge
- Internal illumination and toughened safety glass viewing window
- Double-glazed door construction for energy efficiency
- Firebrick base for crisp, even cooking of pizza base
- 20 minute audible timer
- Separate controls for top and base of oven compartment
- Twin deck models have independent controls for each deck



Single deck pizza ovens							
MODEL	PRICE £	PRICE €	H	W	D	POWER	WT
PO425	£2168	€2494	365	886	825	3kW	71
Internal dimensions			160	550	535		
*PO430	£2408	€2769	365	966	925	4.2kW	101
Internal dimensions			160	630	640		
*PO630	£2973	€3420	365	1286	925	7.2kW	134
Internal dimensions			160	950	640		

Twin deck pizza ovens							
MODEL	PRICE £	PRICE €	H	W	D	POWER	WT
*PO425-2	£3740	€4302	665	886	825	6kW	114
Internal dimensions			2 x 160	2 x 550	2 x 535		
*PO430-2	£4240	€4876	665	966	925	8.4kW	155
Internal dimensions			2 x 160	2 x 630	2 x 640		
*PO630-2	£5297	€6091	665	1286	925	14.4kW	212
Internal dimensions			2 x 160	2 x 950	2 x 640		

Stacking kits for single deck pizza ovens

MODEL	PRICE £	PRICE €	DESCRIPTION
A PO425/SK	£251	€289	Stacking kit for PO425
A PO430/SK	£272	€313	Stacking kit for PO430

Floor stands for pizza ovens (self assembly)

MODEL	PRICE £	PRICE €	DESCRIPTION	H	W	D
A PO425/FS	£602	€693	Floor stand for PO425 and PO425-2	900	886	902
A PO430/FS	£660	€759	Floor stand for PO430 and PO430-2	900	966	1002
A PO630/FS	£761	€875	Floor stand for PO630 and PO630-2	900	1286	1002

Standard Range Pizza Ovens

- Single piece firebrick base for crisp base cooking, perfect for all types of pizza
- Separate heat controls for top and base of the compartment
- Fully insulated doors for energy efficiency and safe operation
- Capacity of 4 x 9" (22cm) or 2 x 12" (30cm) pizzas per deck
- Thermostatic control up to 400°C



Single deck pizza ovens							
MODEL	PRICE £	PRICE €	H	W	D	POWER	WT
PO49X	£1571	€1806	320	810	720	2.9kW	69
Internal dimensions			130	550	545		
PO69X	£1951	€2245	320	1010	720	2.9kW	71
Internal dimensions			175	750	545		

Twin deck pizza ovens							
MODEL	PRICE £	PRICE €	H	W	D	POWER	WT
*PO89X	£2651	€3049	565	810	720	5.7kW	93
Internal dimensions			175	550	540		

Floor stands for pizza ovens

MODEL	PRICE £	PRICE €	DESCRIPTION	H	W	D
A POF5	£716	€823	Floor stand for PO49X	1150	810	670
A PO69X/FS	£893	€1026	Floor stand for PO69X	1150	1010	670

Floor stands for pizza ovens

MODEL	PRICE £	PRICE €	DESCRIPTION	H	W	D
A POF5	£716	€823	Floor stand for PO89X	1150	810	670

TriO High Speed Oven

- Cook, toast and reheat, fresh and frozen foods
- Create an array of perfectly cooked menu items, including pizzas and open sandwiches, in under three minutes
- Compact yet able to accommodate a 12" pizza
- Ventless and adaptable for use in virtually any setting
- 3kW plug-and-play
- Patented speed oven technology, combine TurboAir, ContactBase, and a grill to deliver high quality results, fast
- User-friendly QPad touch screen, addressing challenges such as varying culinary skills and language barriers
- Replace your panini grill, toaster, convection oven and grill



Lincat

TriO Fast Ovens								
MODEL	PRICE £	PRICE €	DESCRIPTION	H	W	D	POWER	WT
TRIO/B	£4329	€4977	Black Glass	367	437	616	2.7kW	37.5
TRIO/S	£4329	€4977	Stainless Steel	367	437	616	2.7kW	37.5
Internal usable dimensions				95	340	355		

MODEL	PRICE £	PRICE €	DESCRIPTION
A TRIO/PL	£130	€151	Plinth
A TRIO/WB	£318	€367	Wall bracket
A TRIO/SK	£123	€141	Stacking kit
A TRIO/BT	£70	€81	Baking tray
A LT01	£67	€79	Paddle
A SH136	£22	€26	Wire rack
C TFS05	£13.50	€15.55	Teflon sheet
A TRIO/USB	£32	€38	USB stick
C TRIO/TT	£79.70	€92.15	Teflon tray
A TRIO/BRT	£199	€229	Branding tray
A TRIO/ET	£23	€27	Multi-tray
C OC01-6	£82.80	€99.35	Daily Oven Cleaner (6 Pack)
C OS01	£24.35	€29.90	Daily Oven Protect

Included with the oven:

Paddle
LT01Wire rack
SH136Teflon sheet
TFS05USB
TRIO/USB

Optional Accessories

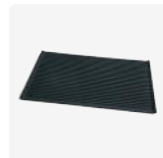
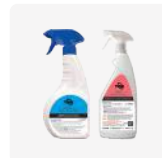
Plinth
TRIO/PLWall bracket
TRIO/WBStacking kit
TRIO/SKBaking tray
TRIO/BTNon-stick Teflon Tray
CIB0/TTBranding tray
TRIO/BRTMulti-tray
CIB0/ETDaily Oven Cleaner OC01-6
Daily Oven Protect OS01

Slot Toasters

- Unique scissor lifting mechanism helps avoid jamming
- Extra deep toasting slots to accommodate larger slices of bread
- Select fewer slots in periods of low demand for energy efficiency
- High quality components and accurate timer control for reliability
- Removable crumb tray makes cleaning quick and easy



⚡ 4 slot toaster							
MODEL	PRICE £	PRICE €	H	W	D	POWER	WT
LT4X	£350	€404	245	392	220	2.3kW	8



⚡ 6 slot toaster							
MODEL	PRICE £	PRICE €	H	W	D	POWER	WT
LT6X	£437	€504	245	482	220	3kW	11

Conveyor Toaster

- High output from compact unit – ideal for breakfast buffets
- Conveyor speed and upper and lower elements are adjustable for versatile control of browning
- Individually controlled elements for one sided toasting of teacakes, burger buns and other products
- Toasts two slices of bread side-by-side to maximise output

⚡ Conveyor toaster							
MODEL	PRICE £	PRICE €	H	W	D	POWER	WT
CT1	£1446	€1664	398	410	668	2.4kW	23

MODEL	PRICE £	PRICE €	DESCRIPTION
A CT1/CC	£35	€41	Lockable cover for control panel

2
YEARUK parts
and labour
warranty
Export
parts
warranty
on all Lincat products

Lincat

GREEN RANGE

Lincat Specialist

Eco Conveyor Toaster

The same output as our popular CT1, but with up to **50% less energy usage** for a typical breakfast serving period

High volume toasting during busy breakfast periods

Versatile control of browning

Perfect for toast or burger buns

Delivering



Reduced energy usage



2 YEAR

UK parts and labour warranty

Export parts warranty

on all Lincat products

Lincat

Electric eco conveyor toaster							
MODEL	PRICE £	PRICE €	H	W	D	POWER	WT
CT2	£2506	€3007	465	365	650	3kW	49.50

- Fast initial heat up <4 mins
- Narrow - only 365mm wide
- Smart controller balances temperature, and energy input for consistent results
- Efficient rapid heat up Quartz I.R. elements with high radiant efficiency and focused energy
- High levels of insulation and active cooling to reduce external temperatures for safer operation and energy savings

Fume Filtration Units

- Powerful centrifugal fans draw cooking fumes through a three part filtration system
- Cleansed air is expelled at top rear of unit
- Hinged top panel gives easy access for cleaning and filter maintenance
- Overheat protection system cuts power to fans in the event of a cooking appliance fire
- Note: these units are not designed to extract smoke and are unsuitable for use with gas appliances



Fume filtration unit							
MODEL	PRICE £	PRICE €	H	W	D	POWER	WT
L3	£2451	€2820	560	924	620	0.35kW	41

Suitable for cooking equipment up to 9 kW total consumption

Fume filtration unit							
MODEL	PRICE £	PRICE €	H	W	D	POWER	WT
L4	£3069	€3530	560	1304	620	0.45kW	54

Suitable for cooking equipment up to 14 kW total consumption

Replacement filter components are available; please contact our spare parts sales desk for prices

2
YEAR

UK parts and labour warranty
Export parts warranty
on all Lincat products



PANTHER



The flexible Panther Hot Cupboards and Holding Bins keep food in perfect condition.

The Panther range of robust Hot Cupboards includes both static and mobile models, meaning that whether you're looking to transport food, form a servery, or a kitchen pass, you'll find the perfect solution for your needs.

The hygienic cupboards are built for ultimate flexibility. They come in different length options and you can also configure the unit to your exact requirements – by selecting a plain top or bain's marie top as well as adding items such as tray slides, gantries and sneeze screens.

Ideally suited for...

The different sizes available and the ability to modify the hot cupboards means that you're sure to find the right one for your establishment. They might include:



Care homes

The smaller 670 model (670mm wide) is made to fit through narrow doorways, making this model perfect for care homes where plated meals are transported from the kitchen to the residents.



Large restaurants

The larger 800 model (800mm wide) has the capacity to hold and transport high volumes of food. It's perfect for carveries.



Schools

The larger 800 model (800mm wide) is ideal for moving prepared dishes to different locations in the perfect condition. Great for school lunchtimes.



Small pubs and restaurants

The static light duty hot cupboard is designed for establishments where space is at a premium or where budgets are tight.

Hold and transport your meals in the perfect condition with Panther. Perfect food stays perfect.

Benefits at a glance

Static or mobile hot cupboards

- Configurable
- Bains marie or plain top models
- 670mm and 800mm deep
- Fan assisted

Static light duty hot cupboards and Hot holding bins - compact and cost effective

- Robust
- Hygienic

PANTHER

Hot Hold Bins

Keep food warm and in perfect serving condition whilst reducing queues and waste.

- Reduces waste – safely hold food for over 1 hour without shrinkage, or loss of flavour or texture
- ***HHB12100** - Flexible – use with 2 x 1/1GN, 4 x 2/4GN or a combination of these! Additional dividers required for 2/4GN
- ***HHB13100** - Flexible – use with 3 x 1/1GN, 6 x 2/4GN or a combination of these! Additional dividers required for 2/4GN
- Intuitive digital controls
- Adjustable temperature for each bin
- Independently controlled upper and lower bins, switch off one bin during quieter periods to save energy
- Easy-access open design speeds up service



HHB12100



HHB13100

Unit is supplied without gastronorm trays

Lincat

Hot hold bins							
MODEL	PRICE £	PRICE €	H	W	D	POWER	WT
HHB12100	£4361	€5016	375	450	640	1.8kW	34
HHB13100	£6503	€7804	540	450	640	2.7kW	45

Accessories

MODEL	PRICE £	PRICE €	DESCRIPTION
A BLA1/1	£52	€61	GN1/1 Slider Cover
A BLA2/4	£52	€61	GN2/4 Slider Cover
A DVD01	£114	€131	Divider for using 2 x GN2/4
A H-PAN01	£128	€147	GN1/1 Food Pan
A H-PAN02	£73	€84	GN1/1 Drain Shelf
A H-PAN04	£94	€109	GN2/4 Long Half Food Pan
A H-PAN05	£40	€46	GN2/4 Long Half Drain Shelf

2
YEAR

UK parts
and labour
warranty

Export
parts
warranty

on all Lincat
products

PANTHER

Hot Hold Bins with Timers

Simple operation shelf timers for precise food holding time tracking for up to 2 hours for each individual bin.

- All the great features of our original bins
- Simple operation shelf timers
- Precise food holding time tracking for up to 2 hours
- 4 individual timers on the HHB12100T and 6 individual timers on the HHB13100T
- Countdown in minutes, under one minute, count down is in seconds
- Individual audible alarm for each bin



Timer strips



HHB12100T



HHB13100T

Unit is supplied without gastronorm trays

Lincat

Hot hold bins							
MODEL	PRICE £	PRICE €	H	W	D	POWER	WT
HHB12100T	£5224	€6269	375	450	640	1.8kW	34
HHB13100T	£7783	€9339	540	450	640	2.7kW	45

Accessories

MODEL	PRICE £	PRICE €	DESCRIPTION
A BLA1/1	£52	€61	GN1/1 Slider Cover
A BLA2/4	£52	€61	GN2/4 Slider Cover
A DVD01	£114	€131	Divider for using 2 x GN2/4
A H-PAN01	£128	€147	GN1/1 Food Pan
A H-PAN02	£73	€84	GN1/1 Drain Shelf
A H-PAN04	£94	€109	GN2/4 Long Half Food Pan
A H-PAN05	£40	€46	GN2/4 Long Half Drain Shelf

2
YEAR

UK parts
and labour
warranty

Export
parts
warranty

on all Lincat
products

PANTHER

Fast Track Products



Order today, available for delivery tomorrow!*

Now you can experience quality and speed!



Models included:

P6P2, P6B2, P6P3, P6B3, P6B3+PG3H, P6B2+PG2H

*If overnight or premium services are required charges will apply

PANTHER

Electricity supply requirements for Panther Hot Cupboards depend on configurations (base models + options), please contact our sales office for guidance.

670 Series Hot Cupboards with Plain Top

- Available as static or mobile versions at no additional cost
- Fully 1/1GN compatible hot cupboard
- Fan assisted hot cupboard gives even heat distribution and lower energy usage
- Supplied with two heavy duty multi-section chrome plated rod shelves
- Four shelf positions
- Accurate digital electronic control of the hot cupboard temperature



Standard plain top models								
MODEL	PRICE £	PRICE €	H	W	D	POWER	WT	
P6P2	£2099	€2414	900	980	670	1.5kW	96	
Internal dimensions			432	795	512			
P6P3	£2483	€2857	900	1205	670	1.5kW	104	
Internal dimensions			432	1020	512			
P6P4	£2830	€3256	900	1530	670	2.5kW	124	
Internal dimensions			432	1345	512			
P6P5	£3157	€3632	900	1855	670	2.5kW	150	
Internal dimensions			432	1670	512			

670 Series Hot Cupboards with Bain Marie Top

- Units available to take 2, 3, 4, or 5 x 1/1 GN containers up to 150mm deep, various combinations available
- Thermostatically controlled bain marie top
- Wet or dry heat operation
- Drain tap located inside hot cupboard allows fast and easy draining
- Plus all the benefits of the plain top models



Standard bain marie models									
MODEL	PRICE £	PRICE €	H	W	D	POWER	1/1GN SIZE	WT	
P6B2	£2794	€3213	912	980	672	2.6kW	2	101	
Internal dimensions			432	795	512				
P6B3	£3213	€3694	912	1205	672	2.8kW	3	111	
Internal dimensions			432	1020	512				
*P6B4	£3673	€4223	912	1530	672	4.9kW	4	137	
Internal dimensions			432	1345	512				
*P6B5	£4058	€4666	912	1855	672	5.2kW	5	161	
Internal dimensions			432	1670	512				

Panther 670 Series hot cupboards are supplied as mobile models with heavy duty castors and one push bar. Please specify legs in lieu of castors and push bar if you require static models at no additional cost.

800 Series Hot Cupboards with Plain Top

- Available as static or mobile versions at no additional cost
- Fully 1/1GN compatible hot cupboard
- Fan assisted hot cupboard gives even heat distribution and lower energy usage
- Supplied with two heavy duty multi-section chrome plated rod shelves
- Four shelf positions
- Accurate digital electronic control of the hot cupboard temperature
- Optional pass through models with removable sliding doors to both sides



800 Series Hot Cupboards with Bain Marie Top

- Units available to take 3, 4, 5 or 6 x 1/1 GN containers up to 150mm deep, various combinations available
- Thermostatically controlled bain marie top
- Wet or dry heat operation
- Drain tap located inside hot cupboard allows fast and easy draining
- Plus all the benefits of the plain top models



Standard plain top models									Pass-through plain top models								
MODEL	PRICE £	PRICE €	H	W	D	POWER	WT		MODEL	PRICE £	PRICE €	H	W	D	POWER	WT	
P8P3	£2794	€3213	900	1205	850	1.5kW	133		P8P3PT	£3356	€3860	900	1205	850	1.5kW	133	
Internal dimensions			432	1020	512				Internal dimensions			432	1020	512			
P8P4	£3223	€3708	900	1530	850	2.5kW	166		P8P4PT	£3847	€4424	900	1530	850	2.5kW	168	
Internal dimensions			432	1345	512				Internal dimensions			432	1345	512			
P8P5	£3607	€4149	900	1855	850	2.5kW	201		P8P5PT	£4279	€4921	900	1855	850	2.5kW	201	
Internal dimensions			432	1670	512				Internal dimensions			432	1670	512			
P8P6	£4000	€4600	900	2180	850	2.5kW	213		P8P6PT	£4718	€5426	900	2180	850	2.5kW	213	
Internal dimensions			432	1995	512				Internal dimensions			432	1995	512			

Standard bain marie models									Pass-through bain marie models								
MODEL	PRICE £	PRICE €	H	W	D	POWER	1/1GN SIZE	WT	MODEL	PRICE £	PRICE €	H	W	D	POWER	1/1GN SIZE	WT
P8B3	£3559	€4093	912	1205	850	2.8kW	3	118	P8B3PT	£4126	€4745	912	1205	850	2.8kW	3	118
Internal dimensions			432	1020	512				Internal dimensions			432	1020	512			
*P8B4	£4106	€4722	912	1530	850	4.9kW	4	135	*P8B4PT	£4733	€5443	912	1530	850	4.9kW	4	135
Internal dimensions			432	1345	512				Internal dimensions			432	1345	512			
*P8B5	£4537	€5218	912	1855	850	5.2kW	5	166	*P8B5PT	£5211	€5993	912	1855	850	5.2kW	5	166
Internal dimensions			432	1670	512				Internal dimensions			432	1670	512			
*P8B6	£4979	€5726	912	2180	850	5.2kW	6	197	*P8B6PT	£5698	€6553	912	2180	850	5.2kW	6	197
Internal dimensions			432	1995	512				Internal dimensions			432	1995	512			

Panther 800 Series hot cupboards are supplied as mobile models with heavy duty castors and one push bar. Please specify legs in lieu of castors and push bar if you require static models at no additional cost.

* Please refer to pages L117 to L118 for electricity supply requirements

PANTHER

Electricity supply requirements for Panther Hot Cupboards depend on configurations (base models + options), please contact our sales office for guidance.

Overshelves

- Heated (with quartz lamps) or ambient models
- Single, double and triple tiered models
- Panther overshelves are factory fitted options and are not available for separate purchase



Single-tier ambient overshelves

MODEL	PRICE £	PRICE €	FOR MODELS*	H	W	D	POWER	WT
A PS2A1	£708	€815	P6B2/P6P2	325	900	320	N/A	8
A PS3A1	£726	€835	P6B3/P6P3/P8B3/P8P3	325	1125	320	N/A	10
A PS4A1	£746	€859	P6B4/P6P4/P8B4/P8P4	325	1450	320	N/A	12
A PS5A1	£770	€885	P6B5/P6P5/P8B5/P8P5	325	1775	320	N/A	14
A PS6A1	£788	€906	P8B6/P8P6	325	2100	320	N/A	17

Two-tier ambient overshelves

MODEL	PRICE £	PRICE €	FOR MODELS*	H	W	D	POWER	WT
A PS2A2	£1131	€1300	P6B2/P6P2	615	900	320	N/A	13
A PS3A2	£1162	€1337	P6B3/P6P3/P8B3/P8P3	615	1125	320	N/A	18
A PS4A2	£1189	€1368	P6B4/P6P4/P8B4/P8P4	615	1450	320	N/A	22
A PS5A2	£1221	€1414	P6B5/P6P5/P8B5/P8P5	615	1775	320	N/A	26
A PS6A2	£1254	€1442	P8B6/P8P6	615	2100	320	N/A	31

Three-tier ambient overshelves

MODEL	PRICE £	PRICE €	FOR MODELS*	H	W	D	POWER	WT
A PS2A3	£1588	€1827	P6B2/P6P2	905	900	320	N/A	19
A PS3A3	£1628	€1872	P6B3/P6P3/P8B3/P8P3	905	1125	320	N/A	25
A PS4A3	£1670	€1921	P6B4/P6P4/P8B4/P8P4	905	1450	320	N/A	32

Single-tier heated overshelves

MODEL	PRICE £	PRICE €	FOR MODELS*	H	W	D	POWER	WT
A PS2H1	£1189	€1368	P6B2/P6P2	325	900	320	0.4kW	10
A PS3H1	£1374	€1581	P6B3/P6P3/P8B3/P8P3	325	1125	320	0.6kW	13
A PS4H1	£1555	€1789	P6B4/P6P4/P8B4/P8P4	325	1450	320	0.8kW	17
A PS5H1	£1710	€1967	P6B5/P6P5/P8B5/P8P5	325	1775	320	1kW	20
A PS6H1	£1889	€2172	P8B6/P8P6	325	2100	320	1.2kW	23

Two-tier heated overshelves

MODEL	PRICE £	PRICE €	FOR MODELS*	H	W	D	POWER	WT
A PS2H2	£2021	€2325	P6B2/P6P2	615	900	320	0.8kW	18
A PS3H2	£2344	€2696	P6B3/P6P3/P8B3/P8P3	615	1125	320	1.2kW	24
A PS4H2	£2680	€3082	P6B4/P6P4/P8B4/P8P4	615	1450	320	1.6kW	31
A PS5H2	£3025	€3478	P6B5/P6P5/P8B5/P8P5	615	1775	320	2kW	37
A PS6H2	£3381	€3888	P8B6/P8P6	615	2100	320	2.4kW	44

Three-tier heated overshelves

MODEL	PRICE £	PRICE €	FOR MODELS*	H	W	D	POWER	WT
A PS2H3	£2842	€3268	P6B2/P6P2	905	900	320	1.2kW	23
A PS3H3	£3338	€3840	P6B3/P6P3/P8B3/P8P3	905	1125	320	1.8kW	32
A PS4H3	£3834	€4411	P6B4/P6P4/P8B4/P8P4	905	1450	320	2.4kW	41
A PS5H3	£4361	€5016	P6B5/P6P5/P8B5/P8P5	905	1775	320	3kW	55
A PS6H3	£4885	€5618	P8B6/P8P6	905	2100	320	3.6kW	65

*Overshelves and gantries may also be specified with the equivalent sized pass-through models

Gantries

- Heated (with quartz lamps) or ambient models
- Stylish curved glass sneeze screen
- Panther gantries are factory fitted options and are not available for separate purchase

Ambient Gantries

MODEL	PRICE £	PRICE €	FOR MODELS*	H	W	D	POWER	WT
A PG2A	£879	€1012	P6B2/P6P2	520	900	460	N/A	14
A PG3A	£964	€1109	P6B3/P6P3/P8B3/P8P3	520	1125	460	N/A	17
A PG4A	£1029	€1185	P6B4/P6P4/P8B4/P8P4	520	1450	460	N/A	21
A PG5A	£1112	€1279	P6B5/P6P5/P8B5/P8P5	520	1775	460	N/A	25

Heated Gantries

MODEL	PRICE £	PRICE €	FOR MODELS*	H	W	D	POWER	WT
A PG2H	£1172	€1348	P6B2/P6P2	520	900	460	0.4kW	14
A PG3H	£1275	€1467	P6B3/P6P3/P8B3/P8P3	520	1125	460	0.6kW	17
A PG4H	£1374	€1581	P6B4/P6P4/P8B4/P8P4	520	1450	460	0.8kW	21
A PG5H	£1475	€1697	P6B5/P6P5/P8B5/P8P5	520	1775	460	1kW	25

Key

- H = Height (mm)
- W = Width (mm)
- D = Depth (mm)
- WT = Packed Weight in kg

2 YEAR

UK parts and labour warranty

Export parts warranty

on all Lincat products



670 Series hot cupboards with factory fitted options and all 800 Series products are built to order. Please contact our sales desk for delivery times.

PANTHER

Electricity supply requirements for Panther Hot Cupboards depend on configurations (base models + options), please contact our sales office for guidance.

800 and 670 Series Gastronorm Packs

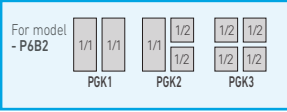

Gastronorm pack configurations are grouped and colour coded to the corresponding model codes. Choose your preferred gastronorm configuration and order the packs as shown in the schematic.

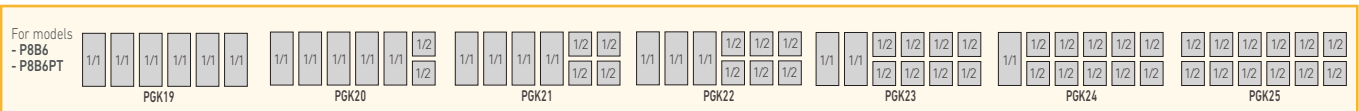
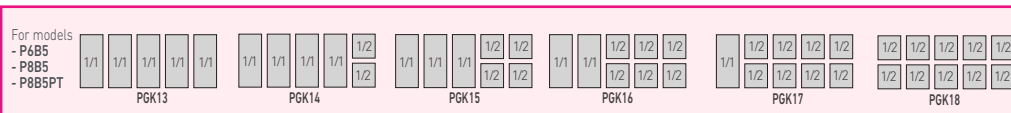
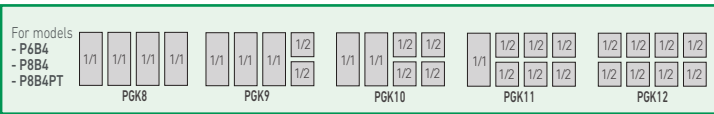
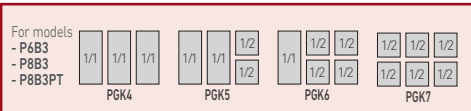

MODEL	PRICE £	PRICE €	DESCRIPTION	1/1GN	1/2GN
A PGK1	£231	€266	GN Pack 1	2	0
A PGK2	£260	€300	GN Pack 2	1	2
A PGK3	£290	€334	GN Pack 3	0	4
A PGK4	£342	€394	GN Pack 4	3	0
A PGK5	£371	€427	GN Pack 5	2	2
A PGK6	£400	€460	GN Pack 6	1	4
A PGK7	£433	€497	GN Pack 7	0	6
A PGK8	£453	€521	GN Pack 8	4	0
A PGK9	£483	€555	GN Pack 9	3	2
A PGK10	£515	€593	GN Pack 10	2	4
A PGK11	£544	€626	GN Pack 11	1	6
A PGK12	£575	€661	GN Pack 12	0	8
A PGK13	£563	€648	GN Pack 13	5	0
A PGK14	£591	€682	GN Pack 14	4	2
A PGK15	£624	€718	GN Pack 15	3	4
A PGK16	£650	€749	GN Pack 16	2	6
A PGK17	£683	€785	GN Pack 17	1	8
A PGK18	£714	€821	GN Pack 18	0	10
A PGK19	£673	€775	GN Pack 19	6	0
A PGK20	£708	€815	GN Pack 20	5	2
A PGK21	£738	€849	GN Pack 21	4	4
A PGK22	£761	€875	GN Pack 22	3	6
A PGK23	£798	€919	GN Pack 23	2	8
A PGK24	£827	€952	GN Pack 24	1	10
A PGK25	£851	€980	GN Pack 25	0	12

Prices are valid only when purchased with a Panther hot cupboard

All gastronorm containers are 150mm deep

A Accessories and Options

800 and 670 Series Accessories

MODEL	PRICE £	PRICE €	DESCRIPTION	Compatible with 800 Series								Compatible with 670 Series								
				P8B3	P8B4	P8B5	P8B6	P8P3	P8P4	P8P5	P8P6	P6B2	P6B3	P6B4	P6B5	P6P2	P6P3	P6P4	P6P5	
A PTS2	£360	€413	Tray slide																	
A PTS3	£395	€454	Tray slide	*																
A PTS4	£422	€486	Tray slide		*															
A PTS5	£453	€521	Tray slide			*														
A PTS6	£484	€556	Tray slide				*													*
A PDL	£248	€286	Door locks	*	*	*	*	*	*	*	*	*	*	*	*	*	*	*	*	*
A PCG	£260	€300	Corner bumpers (set of four)	*	*	*	*	*	*	*	*	*	*	*	*	*	*	*	*	*
A PPB6	£107	€124	Additional push bar								*	*	*	*	*	*	*	*	*	
A PPB8	£131	€152	Additional push bar	*	*	*	*	*	*	*	*	*	*	*	*	*	*	*	*	*
A CP16	£314	€363	1/1GN carvery pad insert	*	*	*	*				*	*	*	*						
A PHTC	£610	€701	1/1GN ceramic panel insert	*	*	*	*				*	*	*	*						
A PHTG	£610	€701	1/1GN glass panel insert	*	*	*	*				*	*	*	*						

A Accessories and Options

Key

- H = Height (mm)
- W = Width (mm)
- D = Depth (mm)
- WT = Packed Weight in kg

2 YEAR

UK parts and labour warranty

Export parts warranty

on all Lincat products

All optional accessories are also available for 800 Series pass-through models with the exception of tray slides

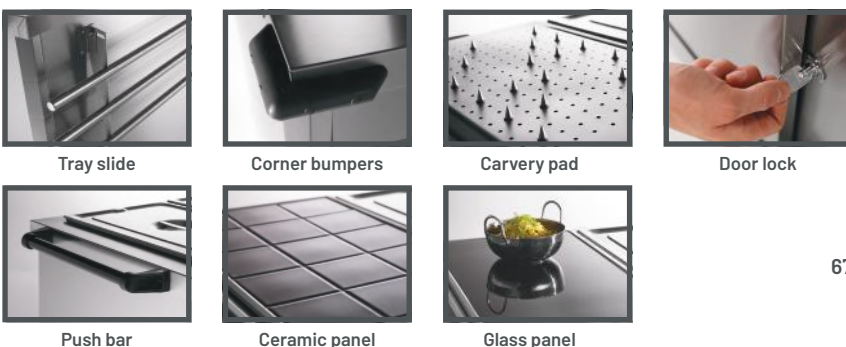

670 Series hot cupboards with factory fitted options and all 800 Series products are built to order. Please contact our sales desk for delivery times.

PANTHER

Electricity supply requirements for Panther Hot Cupboards depend on configurations (base models + options), please contact our sales office for guidance.

SuperPass Series Hot Cupboards

- Fully 1/1 GN compatible hot cupboard, 6 x 1/1 GN in P10SP6PT and 4 x 1/1 GN in the P8SP4PT
- Incorporates a Carter Hoffman Crisp 'N Hold, 2 x 1/1GN bains marie and 2 x water tanks, suitable for boiling vegetables, pasta etc.
- Thermostatically controlled bains marie
- Accurate digital electronic control of water tanks
- Individual drain tap for each water tank at the rear
- Pass through hot cupboard
- Fan assisted hot cupboard for even heat distribution
- Accurate digital electronic control of the hot cupboard temperature
- Three tier heated gantries for pass
- Castors as standard



SuperPass							
MODEL	PRICE £	PRICE €	H	W	D	POWER	WT
*P8SP4PT	£22,880	€26,310	1908	1880	900	11.62kW	230
Internal dimensions			405	1400	490		

2 YEAR UK parts and labour warranty | Export parts warranty on all Lincat products

SuperPass							
MODEL	PRICE £	PRICE €	H	W	D	POWER	WT
*P10SP6PT	£28,564	€32,854	1908	2273	1000	15.52kW	270
Internal dimensions			405	2000	825		

Light Duty Series Hot Cupboards

- Fully insulated for enhanced energy-efficiency
- Adjustable thermostatic control to meet food safety regulations**
- Compact, space saving design
- Ideal for food holding and for use as a plate warmer
- ** Excludes PLH45/XP - electronic temperature control preset to 85°C to maintain food temperature



Hot cupboard							
MODEL	PRICE £	PRICE €	H	W	D	POWER	WT
PLH36	£1007	€1158	900	360	600	0.75kW	41
Internal dimensions			700	315	530		

Hot cupboard							
MODEL	PRICE £	PRICE €	H	W	D	POWER	WT
PLH45	£1055	€1214	900	450	600	0.75kW	47
PLH45/XP	£1068	€1229	850	450	600	1.5kW	45
Internal dimensions			700	405	530		

Hot cupboard							
MODEL	PRICE £	PRICE €	H	W	D	POWER	WT
PLH60	£1266	€1718	900	600	600	1.5kW	60
Internal dimensions			700	555	530		

Hot cupboard							
MODEL	PRICE £	PRICE €	H	W	D	POWER	WT
PLH90	£1510	€1737	900	900	600	2kW	81
Internal dimensions			700	855	530		

* Please refer to pages L117 to L118 for electricity supply requirements



Quality hot water is on tap 24/7 with the FilterFlow range of water boilers.

Easy to use and cheap to run, the reliable FilterFlow range of water boilers offer high output from a minimal footprint.

Whatever your output requirements, you'll find a boiler to cater to your needs. FilterFlow boilers are connected to the main water supply, meaning there's always a steady supply of piping hot water.

Do your employees have to wait in a queue to make a cup of tea at break times? Do you sometimes struggle to deal with a rush of customers asking for teas and coffees all at once? With FilterFlow, these scenarios cease to be a problem.

Ideally suited for...

FilterFlow boilers can provide solutions for a variety of applications where a steady flow of high quality hot water is a must. Places such as:



Offices and staff rooms

Break times can be busy times in offices. Especially when everyone wants a cup of tea at the same time. The FilterFlow water boilers efficiently provide hot water on tap, making the whole process much quicker.



Cafés

Do you often get that moment when there's a rush of customers descending on your café at the same time, all in the mood for a relaxing cup of tea or coffee? Serve them quickly and efficiently with the FilterFlow water boiler range.

A reliable supply of quality filtered hot water whenever you need it. There's no need to wait with the FilterFlow range.

Benefits at a glance

- High quality boiling water 24/7
- High output from narrow footprint
- Easy to use
- Cheap to run
- Connected to the mains water supply

Find your new water boiler

With our chart, it's easy to identify the right new boiler to match your needs.

FX Counter Top Automatic Fill Water Boilers

MODEL	EB3FX	EB3FX/PB	EB3FX/PB/POT	EB3FX/HC/PB	EB3FX/TT	EB3FX/TALL	EB4FX	EB6FX	EB6TFX
PAGE	L107	L107	L107	L108	L108	L108	L107	L107	L107
Feature	The original Lincat boiler with touchscreen control - variable temp, ECO mode, descale sensor, descale programme and on/off timer	Push button operation ideal for front of house applications. Cup model - Ideal for filling cups and mugs.	Push button operation ideal for front of house applications. Pot model - Ideal for filling teapots and cafetieres	Where hot and chilled water is required	Twin taps for twin temperature output, for more than one operator at a time	For operators who only have a three pin plug socket but who experience a high influx of customers in bursts, such as garden centres and farm shops who welcome coach and leisure venues and stadia with intermissions	For high volume requirements	For higher volume requirements	For higher volume requirements with more than one operator at a time
Rapid draw off cups	55	55	55	25 HOT & 60 COLD	45	85	55	90	90
Rapid draw off litres	11	11	11	5 HOT & 12 COLD	2 x 4.5	17	11	18	18
Hourly output cups	155	155	155	140 HOT & 60 COLD	125	155	225	300	300
Hourly output litres	31	31	31	28 HOT & 12 COLD	25	31	45	60	60
Outlet	Tap	Push Button	Push Button	Push Button	Twin Tap	Tap	Tap	Tap	Twin Tap
Power Supply									
Installation	UK 13A Plug	UK 13A Plug	UK 13A Plug	UK 13A Plug	UK 13A Plug	UK 13A Plug	1 phase	1 phase	1 phase
Total Power kW	3	3	3	3	3	3	4.5	6	6
Dimensions									
H x W x D mm	596 x 250 x 525	596 x 250 x 525	596 x 250 x 525	596 x 250 x 525	596 x 250 x 525	685 x 250 x 525	596 x 250 x 525	685 x 250 x 525	685 x 250 x 525

Wall Mounted Automatic Fill Water Boilers

MODEL	M3F	WMB3F	M5F	WMB5F	M7F	WMB7F	M10F
PAGE	L110	L109	L110	L109	L110	L109	L110
Feature	A robust, British-engineered quality water boiler for where high performance is required on a three pin plug and at a competitive price.	With a sleek glass finish, these boilers are ideal for front of house, office kitchens or staff rooms.	A robust, British-engineered quality water boiler for where high performance is required on a three pin plug and at a competitive price.	With a sleek glass finish, these boilers are ideal for front of house, office kitchens or staff rooms.	A robust, British-engineered quality water boiler for where high performance and higher volume output is required on a 3 pin plug and at a competitive price.	With a sleek glass finish, these boilers are ideal for front of house, larger office kitchens or staff rooms.	A robust, British-engineered quality water boiler for where high performance and higher volume output is required on a 3 pin plug and at a competitive price.
Rapid draw off cups	18	18	28	28	38	38	50
Rapid draw off litres	3.5	3.5	5.5	5.5	7.5	7.5	10
Hourly output cups	140	140	140	140	140	140	140
Hourly output litres	28	28	28	28	28	28	28
Outlet	Tap	Tap	Tap	Tap	Tap	Tap	Tap
Power Supply	UK 13A Plug	1 phase	UK 13A Plug	1 phase	UK 13A Plug	1 phase	UK 13A Plug
Total Power kW	3	3	3	3	3	3	3
Dimensions							
H x W x D mm	398 x 300 x 203	413 x 300 x 184	448 x 340 x 203	462 x 340 x 184	563 x 340 x 203	462 x 340 x 224	580 x 340 x 296



FilterFlow Automatic Water Boilers (Tap Dispense)

- High quality boiling water on tap 24 hours a day
- Built-in water filtration system
- High volume, easy change FilterFlow cartridge
- Large, colour touchscreen display
- Narrow 250mm footprint
- Eco setting reduces the volume of boiling water by 50%
- Intelligent predictive eco setting learns usage patterns and adjusts water volume
- 7-day timer
- Adjustable water temperature from 70°C - 98°C
- Enhanced diagnostics
- Self descale programme to reduce the build-up of scale
- Twin tap version - ideal for the busiest periods



Lincat

FilterFlow automatic water boiler							
MODEL	PRICE £	PRICE €	H	W	D	POWER	WT
EB3FX	£958	€1103	596	250	525	3kW	16
Rapid draw off			11 litres		55 cups		
Output per hour			31 litres		155 cups		

FilterFlow automatic water boiler							
MODEL	PRICE £	PRICE €	H	W	D	POWER	WT
*EB4FX	£1159	€1333	596	250	525	4.5kW	15
Rapid draw off			11 litres		55 cups		
Output per hour			45 litres		155 cups		

FilterFlow automatic water boiler							
MODEL	PRICE £	PRICE €	H	W	D	POWER	WT
*EB6FX	£1253	€1441	685	250	525	6kW	19
Rapid draw off			18 litres		90 cups		
Output per hour			60 litres		300 cups		

FilterFlow automatic water boiler (twin tap)							
MODEL	PRICE £	PRICE €	H	W	D	POWER	WT
*EB6TFX	£1354	€1558	685	250	525	6kW	19
Rapid draw off			18 litres		90 cups		
Output per hour			60 litres		300 cups		

MODEL	PRICE £	PRICE €	DESCRIPTION
A BR55	£93	€108	Wall mounting kit for models EB3FX and EB4FX
A BR56	£102	€118	Wall mounting kit for EB6FX and EB6TFX
C FC04	£72.15	€83	Filter Cartridge
C DP10	£23.75	€27.30	Descaler powder
A EBHF01	£118	€136	Hands free water boiler tap adapter

FilterFlow Automatic Water Boiler (Push-Button)

- Convenient push button operation
- Cup model - Ideal for front of house and self service operations
- **NEW for 2025!** Pot model - Ideal for filling teapots and cafeterias with 217mm clearance
- Lockable mode prevents water being dispensed without the input of a PIN code - perfect for schools, prisons, care homes and settings with vulnerable individuals
- Plus all the features of the EB3FX

FilterFlow large capacity automatic water boiler							
MODEL	PRICE £	PRICE €	DESCRIPTION	H	W	D	POWER WT
EB3FX/PB	£1209	€1390	Cup model	596	250	525	3kW 18
EB3FX/PB/POT	£1209	€1390	Pot model	596	250	525	3kW 18
Rapid draw off				11 litres		55 cups	
Output per hour				31 litres		155 cups	

MODEL	PRICE £	PRICE €	DESCRIPTION
A BR55	£93	€108	Wall mounting kit
C FC04	£72.15	€83	Filter Cartridge
C DP10	£23.75	€27.30	Descaler powder



* Please refer to pages L117 to L118 for electricity supply requirements



FilterFlow Twin Temperature Automatic Water Boiler (Tap Dispense)

- Tanks can be set to different temperatures – ideal for brewing black teas at 98°C and green teas at 71°C
- High quality boiling water on tap 24 hours a day
- Large colour touchscreen display
- Built-in water filtration system improves water quality and reduces scale build-up
- High volume, easy change FilterFlow cartridge
- Narrow 250mm footprint
- 7-day timer
- Adjustable water temperature – from 70°C – 98°C, ideal for all types of beverage
- Enhanced diagnostics
- Self descale programme to reduce the build-up of scale



FilterFlow large capacity automatic water boiler							
MODEL	PRICE £	PRICE €	H	W	D	POWER	WT
EB3FX/TT	£1367	€1573	596	250	525	3kW	20
Rapid draw off			2 x 4.5 litres		45 cups		
Output per hour			25 litres		125 cups		

MODEL	PRICE £	PRICE €	DESCRIPTION
A BR55	£93	€108	Wall mounting kit
C FC04	£72.15	€83	Filter Cartridge
C DP10	£23.75	€27.30	Descaler powder
A EBHF01	£118	€136	Hands free water boiler tap adapter

FilterFlow Automatic Water High Capacity Boiler (Tap Dispense)

- For high volume requirements, with rapid draw off of 17 litres
- Ideal for operators that experience a high influx of customers in a short space of time, such as sports stadia, leisure venues, garden centres and farm shops that welcome coach trips
- UK 3 pin plug, removing the need for hard wiring, which means operators can simply plug in and switch on
- All the other great features of our popular EB3FX

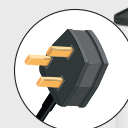

FilterFlow large capacity automatic water boiler							
MODEL	PRICE £	PRICE €	H	W	D	POWER	WT
EB3FX/TALL	£1193	€1372	685	250	525	3kW	18.5
Rapid draw off (hot)			17 litres		85 cups		
Output per hour (hot)			31 litres		155 cups		

MODEL	PRICE £	PRICE €	DESCRIPTION
C FC04	£72.15	€83	Filter Cartridge
C DP10	£23.75	€27.30	Descaler powder
S BR56	£102	€118	Wall Bracket
A EBHF01	£118	€136	Hands free water boiler tap adapter

FilterFlow Automatic Water Boiler and Chiller (Push-Button)

- Convenient push button operation, ideal for front of house and self service applications
- Filtered chilled and hot water on tap 24 hours a day
- Space saving and economic – no need for a separate boiler and chiller
- Narrow 250mm footprint saves valuable counter space without compromising capacity or performance
- Built-in water filtration system improves water quality and reduces scale build-up
- High volume, easy change FilterFlow cartridge
- Easily operated from a large, colour touchscreen display. Menu navigation is quick and easy with the temperature and timer simple to adjust
- Enhanced diagnostics identify possible causes. The on screen diagnostic information will enable the engineer to identify the parts needed and repair your water boiler at first visit



FilterFlow automatic water boiler (Hot & Cold)							
MODEL	PRICE £	PRICE €	H	W	D	POWER	WT
EB3FX/HC/PB	£2509	€2886	596	250	570	3kW	32
Rapid draw off (hot)			5 litres		25 cups		
Rapid draw off (cold)			12 litres		60 cups		
Output per hour (hot)			28 litres		140 cups		
Output per hour (cold)			12 litres		60 cups		

MODEL	PRICE £	PRICE €	DESCRIPTION
A BR57	£94	€109	Wall mounting kit
C FC04	£72.15	€83	Filter Cartridge
C DP10	£23.75	€27.30	Descaler powder

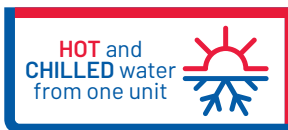

* Please refer to pages L117 to L118 for electricity supply requirements



Wall Mounted, Automatic Water Boilers with Tap Dispense

Introducing the WMB5F (5 litre) and the WMB7F (7 litre) wall mounted automatic water boilers based on our popular 3 litre WMB3F. With a sleek glass finish available in black or white, these boilers are ideal for front of house, office kitchens or staff rooms.

- Exceptionally compact and perfect for locations with limited space
- High quality boiling water on tap 24 hours a day
- Built-in water filtration system improves water quality and reduces scale build-up
- Dispense temperature can be reduced to 70°C perfect for delicate specialty teas
- High volume, easy change FilterFlow cartridge
- Extra room underneath for larger cups, teapots, jugs and airpots to be filled
- Advanced diagnostics with LCD panel showing boiler status
- Cool-to-touch 6mm thick toughened glass fascia to withstand hard knocks
- Require hard wiring to the mains



⚡ WMB3F FilterFlow wall mounted automatic water boiler								
MODEL	PRICE £	PRICE €	GLASS	H	W	D	POWER	WT
*WMB3F/B	£919	€1057	Black	413	300	185	3kW	11
*WMB3F/W	£919	€1057	White	413	300	185	3kW	11
Rapid draw off				3.5 litres		18 cups		
Output per hour				28 litres		140 cups		

⚡ WMB5F FilterFlow wall mounted automatic water boiler								
MODEL	PRICE £	PRICE €	GLASS	H	W	D	POWER	WT
*WMB5F/B	£991	€1141	Black	462	340	184	3kW	11
*WMB5F/W	£991	€1141	White	462	340	184	3kW	11
Rapid draw off				5.5 litres		28 cups		
Output per hour				28 litres		140 cups		

Accessories

	MODEL	PRICE £	PRICE €	DESCRIPTION
C	FC02	£72.15	€83	Filter Cartridge
C	DP10	£23.75	€27.30	Descaler powder
S	DR72	£236	€272	Drip tray for WMB3F & WMB5F



⚡ WMB7F FilterFlow wall mounted automatic water boiler								
MODEL	PRICE £	PRICE €	GLASS	H	W	D	POWER	WT
*WMB7F/B	£1063	€1223	Black	462	340	224	3kW	12
*WMB7F/W	£1063	€1223	White	462	340	224	3kW	12
Rapid draw off				7.5 litres		38 cups		
Output per hour				28 litres		140 cups		

Accessories

	MODEL	PRICE £	PRICE €	DESCRIPTION
C	FC02	£72.15	€83	Filter Cartridge
C	DP10	£23.75	€27.30	Descaler powder
S	DR98	£254	€292	Drip tray for WMB7F



Wall Mounted Automatic Water Boilers

The M3F, M5F, M7F and M10F provide a **robust, quality water boiler** with a range of features at a **competitive price!**

- Available in 3, 5.5, 8 and 10-litre sizes
- Connected to mains water supply to deliver instant, continuous, high-quality boiling water
- Wall mounted, compact design
- Easy installation – UK 3 pin plug and three screws
- Built-in water filtration system, complete with FilterFlow's popular high-volume easy to change cartridge
- Adjustable water temperature from 70°C – 96°C
- Precise electronic temperature control system
- LCD information panel
- Enhanced multi-level diagnostics
- Easy clean stainless steel finish



Automatic fill wall mounted water boilers									
MODEL	PRICE £	PRICE €	H	W	D	RAPID DRAW OFF	OUTPUT PER HOUR	POWER	WT
M3F	£740	€851	398	300	269	3.5L / 18 cups	28L / 140 cups	3kW	12
M5F	£752	€866	448	340	269	5.5L / 28 cups	28L / 140 cups	3kW	13
M7F	£801	€921	563	340	269	8L / 38 cups	28L / 140 cups	3kW	15
M10F	£981	€1128	580	340	296	10L / 50 cups	28L / 140 cups	3kW	15

MODEL	PRICE £	PRICE €	DESCRIPTION
C FC04	£72.15	€83	Filter Cartridge
C DP10	£23.75	€27.30	Descaler powder
A DR94	£254	€292	Drip tray - M3F
A DR95	£254	€292	Drip tray - M5F and M7F
A DR96	£232	€267	Drip tray - M10F

SEAL



Tempt customers to spend more with Seal displays and merchandisers.

You can rely on the Seal displays, merchandisers, cabinets and showcases to hold food in optimum conditions – at all times.

The sleek and elegant designs entice customers to spend more as you can tempt them with your already prepared meals and snacks.

Whether you're looking for a front of house or back of house solution, and whatever the type of food, from hot meats, pizzas and pies, to cold sandwiches and yoghurts, you'll find the perfect model for you in the Seal range.

Ideally suited for...

The Seal range is ideal for anyone who needs a method for holding food at the right temperature while tempting customers to spend more at the same time.



School and college canteens

Keep student meals and snacks in the optimum condition and encourage additional sales.



Hotels

Perfect for showcasing and holding foods during breakfast as well as for other meals.



Sporting venues

Entice customers before, during and after the game with clear and well-designed displays of appetizing food.



Cafés

Keep baked goods and other foods in the perfect condition while tempting your customers to make additional purchases at the checkout.

The Seal range combines the functional - keeping food at the optimum temperature - with an attractive design that can entice customers to make additional purchases.

Benefits at a glance

- Showcase your food and increase sales
- Ambient, refrigerated and heated merchandisers and displays
- Keep food in optimum condition
- Front and back service option
- Reliable
- Sturdy
- Hygienic

SEAL



GRAB & GO!

GRAB & GO!

GRAB & GO!

GRAB & GO!

Hot Air Displays

HAD40 and HAD50

The perfect way to display hot food and generate grab & go sales. The convected hot air system ensures food is not only safe but also kept in prime condition at just the right temperature.



Lincat

- Maintains the ideal holding temperature of 65°C - 70°C, ideal for all sorts of pre-cooked hot foods, including pizzas, pies and sausage rolls
- Compact 400 and 500mm wide design for where counter space is at a premium
- Food is displayed on four 'easy to remove' tilted shelves within the two compartments
- Hot air curtain at the front minimises heat loss
- Electronic temperature control to within +/-1°C
- Secondary safety limit thermostat
- Stainless steel point of sale holders
- Lighting providing a bright interior with user replaceable light bulb
- Easy clean stainless steel external finish
- Easy clean stainless interior
- Toughened glass sides and front deflectors
- Non-slip feet

Hot air displays							
MODEL	PRICE £	PRICE €	H	W	D	POWER	WT
HAD40	£2639	€3035	845	400	585	2.2kW	49
HAD50	£2685	€3088	845	500	585	2.2kW	57

MODEL	PRICE £	PRICE €	DESCRIPTION
A PSH40	£298	€342	Pizza Shelf insert for HAD40 - set of 4
A PSH50	£298	€342	Pizza Shelf insert for HAD50 - set of 4

GRAB & GO!

GRAB & GO!

GRAB & GO!

GRAB & GO!

Upright Heated Merchandisers

Pie Cabinets

- Robust stainless steel construction
- Minimum food holding temperature of 72°C
- Thermostatic control up to 95°C
- Humidity feature keeps food in perfect condition
- User-replaceable light bulbs



- Stylish, rounded and compact design
- Minimum food holding temperature of 72°C
- Thermostatic control up to 95°C
- Robust stainless steel construction
- Three chrome-plated rod shelves in LPW model and four in LPW/LR model
- Additionally, model LPW/LR offers
 - Two 25-watt diffused switchable lights with user-changeable bulbs for enhanced food presentation
 - Humidity feature to keep food in perfect condition for longer, minimising waste



Upright heated merchandiser with rotating rack							
MODEL	PRICE £	PRICE €	H	W	D	POWER	WT
UM50	£1762	€2026	783	562	562	1400W	53
UM50D	£1955	€2249	783	562	562	1400W	51

Upright heated merchandiser with static rack							
MODEL	PRICE £	PRICE €	H	W	D	POWER	WT
UMS50	£1552	€1785	783	562	562	1400W	54
UMS50D	£1786	€2054	783	562	562	1400W	54

Pie cabinet							
MODEL	PRICE £	PRICE €	H	W	D	POWER	WT
LPW	£785	€903	520	710	330	750W	30

Pie cabinet with illumination and humidity feature							
MODEL	PRICE £	PRICE €	H	W	D	POWER	WT
LPW/LR	£907	€1044	520	710	330	800W	32

2 YEAR UK parts and labour warranty | Export parts warranty
on all Lincat products

Key

- H = Height (mm)
- W = Width (mm)
- D = Depth (mm)
- WT = Packed Weight in kg

650 Range Curved Front Heated

- Minimum food holding temperature of 72°C
- Precise thermostatic control up to 95°C with digital display
- Humidity feature prevents food drying out
- Daylight-balanced illumination with easy-change light tubes
- Options for back-service or self-service operation



Heated merchandiser							
MODEL	PRICE £	PRICE €	H	W	D	POWER	WT
C6H/75B	£2734	€3145	755	750	650	1520W	69
C6H/75S	£2812	€3233	755	750	650	1520W	67

Heated merchandiser							
MODEL	PRICE £	PRICE €	H	W	D	POWER	WT
C6H/100B	£3007	€3458	755	1000	650	2020W	83
C6H/100S	£3094	€3559	755	1000	650	2020W	82

500 Range Heated

- Minimum food holding temperature of 72°C
- Thermostatic control up to 95°C
- Daylight-balanced illumination with easy-change light tubes
- Humidity feature prevents food drying out
- Switchable heat control allows use as an ambient display
- Options for back-service or self-service operation



Heated merchandiser							
MODEL	PRICE £	PRICE €	H	W	D	POWER	WT
D5H/75B	£1837	€2113	575	750	500	1520W	58
D5H/75S	£2069	€2379	575	750	500	1520W	50

Heated merchandiser							
MODEL	PRICE £	PRICE €	H	W	D	POWER	WT
D5H/100B	£2037	€2343	575	1000	500	2020W	62
D5H/100S	£2227	€2562	575	1000	500	2020W	62

500 Range Refrigerated

- Holds food at 3°C - 7°C in ambient conditions up to 25°C and 60% relative humidity
- Thermostatic temperature control with digital display
- Daylight-balanced illumination with easy-change light tubes
- Double-glazed front and sides for extra energy efficiency and low running costs
- Option for back-service or self-service operation



Refrigerated merchandiser								
MODEL	PRICE £	PRICE €	POWER UNIT	H	W	D	POWER	WT
D5R/100B	£3648	€4196	Right	575	1000	500	602W	87
D5R/100S	£3866	€4447	Right	575	1000	500	602W	84
Power pack				575	250	500		

Key

- H = Height (mm)
- W = Width (mm)
- D = Depth (mm)
- WT = Packed Weight in kg

Product codes with B denote back service option. Those with S denote self service.



Heated Food Display Showcases

- Minimum food holding temperature of 72°C
- Daylight-balanced illumination with easy-change light tubes
- Precise thermostatic control up to 95°C with digital display

- Humidity feature prevents food drying out
- Supplied with 65mm deep 1/1GN containers
- Optional flat base plate



Heated showcase							
MODEL	PRICE £	PRICE €	H	W	D	POWER	WT
SCH785	£2682	€3085	665	785	750	1550W	70

MODEL	PRICE £	PRICE €	DESCRIPTION
A BP785	£121	€139	Base plate for SCH785

Heated showcase							
MODEL	PRICE £	PRICE €	H	W	D	POWER	WT
SCH1085	£2893	€3327	665	1085	750	2050W	88

MODEL	PRICE £	PRICE €	DESCRIPTION
A BP1085	£147	€169	Base plate for SCH1085

Glass Display Cases

- Toughened safety glass throughout with sturdy 10mm thick base glass and strong stainless steel shelf support brackets for extra rigidity
- 6mm thick removable shelves - safe and easy to clean

- Generous 150mm shelf height for versatile display of food and non-food items
- Non-slip rubber feet for extra safety and security



Glass display cases with open backs							
MODEL	PRICE £	PRICE €	H	W	D	WT	
GC36	£632	€727	490	607	350	25	
GC39	£704	€820	490	907	350	32	
GC46	£692	€796	645	607	350	31	

Glass display cases with rear sliding doors							
MODEL	PRICE £	PRICE €	H	W	D	WT	
GC36D	£696	€801	490	607	350	30	
GC39D	£802	€922	490	907	350	40	
GC46D	£814	€937	645	607	350	38	



SEAL

Heated Displays with Gantries

- Thermostatic control of base heat
- Minimum food holding temperature of 72°C
- Aluminium surface for energy-efficient heat conduction
- Accepts 1/1GN containers
- Overhead gantry with halogen heat lamps
- Toughened glass sneeze screen for hygiene and safety
- Optional bain marie adaptor holds 2/3GN containers



Heated display with gantry (2 x 1/1 GN)							
MODEL	PRICE £	PRICE €	H	W	D	POWER	WT
LD2	£924	€1062	560	790	538	1500W	25

Heated display with gantry (2 x 1/1 GN)							
MODEL	PRICE £	PRICE €	H	W	D	POWER	WT
LD3	£1168	€1344	560	1130	538	2400W	35

Heated display with gantry (4 x 1/1 GN)							
MODEL	PRICE £	PRICE €	H	W	D	POWER	WT
LD4	£1373	€1580	560	1470	538	2750W	40

Bain marie adaptor including GN dishes and lids

MODEL	PRICE £	PRICE €	FOR MODEL	PACK QUANTITY
A LDBM2	£397	€457	LD2	2 x 2/3 GN

Bain marie adaptor including GN dishes and lids

MODEL	PRICE £	PRICE €	FOR MODEL	PACK QUANTITY
A LDBM3	£537	€618	LD3	3 x 2/3 GN

Bain marie adaptor including GN dishes and lids

MODEL	PRICE £	PRICE €	FOR MODEL	PACK QUANTITY
A LDBM4	£647	€744	LD4	4 x 2/3 GN

Heated Display Bases

- Thermostatic control
- Minimum food holding temperature of 72°C
- Aluminium surface for energy-efficient heat conduction
- Accepts 1/1GN containers
- Affordable choice where overhead heat and illumination is not required
- Optional bain marie adaptor holds 2/3GN containers



Heated display base (1 x 1/1 GN)							
MODEL	PRICE £	PRICE €	H	W	D	POWER	WT
HB1	£491	€565	112	380	505	500W	10



Heated display base (3 x 1/1 GN)							
MODEL	PRICE £	PRICE €	H	W	D	POWER	WT
HB3	£664	€764	112	1094	505	1400W	19

Bain marie adaptor including GN dishes and lids

MODEL	PRICE £	PRICE €	SIZE	TO FIT
A HBBM3	£538	€618	3 x 2/3 GN	HB3



Heated display base (2 x 1/1 GN)							
MODEL	PRICE £	PRICE €	H	W	D	POWER	WT
HB2	£576	€662	112	754	505	1000W	14

Bain marie adaptor including GN dishes and lids

MODEL	PRICE £	PRICE €	SIZE	TO FIT
A HBBM2	£402	€462	2 x 2/3 GN	HB2



Heated display base (4 x 1/1 GN)							
MODEL	PRICE £	PRICE €	H	W	D	POWER	WT
HB4	£814	€937	112	1434	505	1750W	24

Bain marie adaptor including GN dishes and lids

MODEL	PRICE £	PRICE €	SIZE	TO FIT
A HBBM4	£670	€772	4 x 2/3 GN	HB4

2 YEAR
UK parts and labour warranty
Export parts warranty
on all Lincat products



Refrigerated Food Display Bars

- Precise thermostatic control with digital display
- Holds food at 3°C-7°C in ambient conditions up to 25°C and 60% relative humidity
- Efficient R134a refrigerant ensures optimum performance

- Well base and side refrigeration ensures even cooling throughout bar length
- Fully welded stainless steel construction
- Stylish low profile design holds 100mm deep gastronorm containers



FDB5 - Food Display Bar with optional back service glass



FDB8 - Food Display Bar with optional stainless steel lid



FDB6 - Food Display Bar with optional self service glass



FDB10 - Food Display Bar with optional back service glass



FDB4 - Food Display Bar with optional back service glass

Food display bars (base units)							
MODEL	PRICE £	PRICE €	H	W	D	POWER	WT
FDB4	£2118	€2436	245	1056	377	175W	27
FDB5	£2155	€2479	245	1222	377	175W	28
FDB6	£2184	€2512	245	1399	377	175W	30
FDB8	£2242	€2579	245	1753	377	175W	34
FDB10	£2282	€2623	245	2107	377	175W	39

Stainless steel lids				
MODEL	PRICE £	PRICE €	TO FIT	
A DBL4	£239	€275	FDB4	
A DBL5	£245	€282	FDB5	
A DBL6	£264	€305	FDB6	
A DBL8	£271	€311	FDB8	
A DBL10	£297	€341	FDB10	

Back service curved glass covers				
MODEL	PRICE £	PRICE €	TO FIT	
A BSG4	£470	€541	FDB4	
A BSG5	£470	€541	FDB5	
A BSG6	£470	€541	FDB6	
A BSG8	£603	€694	FDB8	
A BSG10	£678	€780	FDB10	

Self service curved glass covers				
MODEL	PRICE £	PRICE €	TO FIT	
A SSG4	£502	€578	FDB4	
A SSG5	£502	€578	FDB5	
A SSG6	£521	€600	FDB6	
A SSG8	£613	€705	FDB8	
A SSG10	£704	€810	FDB10	

Wall brackets				
MODEL	PRICE £	PRICE €	TO FIT	
A DBWB	£163/pair	€188/pair	FDB	

Packs of 100mm deep 1/3 GN containers with stainless steel lids for Food Display Bars					
MODEL	PRICE £	PRICE €	FOR MODEL	PACK QUANTITY	
A SGP1004	£339	€390	FDB4	4	
A SGP1005	£419	€482	FDB5	5	
A SGP1006	£491	€565	FDB6	6	
A SGP1008	£645	€742	FDB8	8	
A SGP10010	£803	€923	FDB10	10	

Packs of 100mm deep 1/3 GN containers with transparent acrylic lids for Food Display Bars					
MODEL	PRICE £	PRICE €	FOR MODEL	PACK QUANTITY	
A SGP1004A	£347	€400	FDB4	4	
A SGP1005A	£439	€505	FDB5	5	
A SGP1006A	£508	€585	FDB6	6	
A SGP1008A	£670	€771	FDB8	8	
A SGP10010A	£835	€962	FDB10	10	

Refrigerated Food Preparation Bars

- Precise thermostatic control with digital display
- Holds food at 3°C-7°C in ambient conditions up to 25°C and 60% relative humidity
- Efficient R134a refrigerant ensures optimum performance

- Well base and side refrigeration ensures even cooling throughout bar length
- Robust stainless steel construction
- Large capacity - holds 150mm deep gastronorm containers

Gastronorm Configurations

Food Preparation Bars



FPB5 - Food Preparation Bar with optional back service glass



FPB7 - Food Preparation Bar with optional stainless steel lid



FPB5 (5 x 1/3GN)



FPB7 (7 x 1/3GN)

Food preparation bars (base units)							
MODEL	PRICE £	PRICE €	H	W	D	POWER	WT
FPB5	£1623	€1868	262	1225	377	175W	31
FPB7	£1714	€1972	262	1576	377	175W	35

Stainless steel lids				
MODEL	PRICE £	PRICE €	TO FIT	
A PBL5	£223	€257	FPB5	
A PBL7	£232	€267	FPB7	

Back service square glass covers				
MODEL	PRICE £	PRICE €	TO FIT	
A PBG5	£281	€324	FPB5	
A PBG7	£296	€341	FPB7	

Wall brackets				
MODEL	PRICE £	PRICE €	TO FIT	
A DBWB	£163/pair	€188/pair	FPB	

Packs of 150mm deep 1/3 GN containers with stainless steel lids for Food Preparation Bars					
MODEL	PRICE £	PRICE €	FOR MODEL	PACK QUANTITY	
A SGP1505	£508	€585	FPB5	5	
A SGP1507	£728	€837	FPB7	7	

Packs of 150mm deep 1/3 GN containers with transparent acrylic lids for Food Preparation Bars					
MODEL	PRICE £	PRICE €	FOR MODEL	PACK QUANTITY	
A SGP1505A	£538	€619	FPB5	5	
A SGP1507A	£737	€848	FPB7	7	

Electricity Supply Requirements

(page 1 of 2)

Electrical products not listed on this page are supplied for operation on a 230/240v, 13 amp supply.

Brand	Product Code	Power Supply/ Connection Type	Electrical Supply Rating [watts]	Single Phase		Three Phase			
				Amps	Voltage	Amps - Phase 1	Amps - Phase 2	Amps - Phase 3	Voltage
Lincat	AS4	1-phase	4,500	19.60	230	N/A			
Lincat	CO235M	1-phase or 3-phase	4,800	20.5	230	6.9	6.9	6.9	400
Lincat	CO235T	1-phase or 3-phase	4,800	20.5	230	6.9	6.9	6.9	400
Lincat	DF36	1-phase or 3-phase	6,000	26.0	230	13.0	13.0	N/A	400
Lincat	DF39	1-phase or 3-phase	9,000	39.0	230	13.0	13.0	13.0	400
Lincat	DF46	1-phase or 3-phase	6,000	26.0	230	13.0	13.0	N/A	400
Lincat	DF49	1-phase or 3-phase	9,000	39.0	230	13.0	13.0	13.0	400
Lincat	DF612	1-phase or 3-phase	2 x 6,000	2 x 26.0	230	2 x 13.0	2 x 13.0	N/A	400
Lincat	DF618	1-phase or 3-phase	2 x 9,000	2 x 39.0	230	2 x 13.0	2 x 13.0	2 x 13.0	400
Lincat	DF66/ST	1-phase or 3-phase	6,000	26.0	230	13.0	13.0	N/A	400
Lincat	EB4FX	1-phase	4,500	20	230	N/A			
Lincat	EB6FX	1-phase	6,000	26	230	N/A			
Lincat	EB6TFX	1-phase	6,000	26	230	N/A			
Lincat	ECG6	1-phase or 3-phase	8,000	34.8	230	11.6	11.6	11.6	400
Lincat	ECG9	3-phase	13,300	N/A		23.2	23.2	11.6	400
Lincat	ECG9/WT	3-phase	13,300	N/A		23.2	23.2	11.6	400
Lincat	EC09	1-phase or 3-phase	7,500	32.6	230	6.7	6.7	13.0	400
Lincat	ESLR6C	1-phase or 3-phase	11,000	47.8	230	17.4	15.2	15.2	400
Lincat	ESLR9C	3-phase	16,500	N/A		27.9	27.9	15.9	400
Lincat	ESLR9C/SPH	1-phase	13,000	56.5 [1 supp.]; 30.4/26.1 [2 supp.]	230	N/A			
Lincat	GS4/E	1-phase	3,700	16.1	230	N/A			
Lincat	GS6	1-phase	3,000	13.0	230	N/A			
Lincat	GS6/C	1-phase	3,000	13.0	230	N/A			
Lincat	GS6/T	1-phase or 3-phase	4,000	17.4	230	8.7	8.7	N/A	400
Lincat	GS6/T/E	1-phase or 3-phase	5,600	24.3	230	12.2	12.2	N/A	400
Lincat	GS6/TFR	1-phase or 3-phase	4,000	17.4	230	8.7	8.7	N/A	400
Lincat	GS6/TR	1-phase or 3-phase	4,000	17.4	230	8.7	8.7	N/A	400
Lincat	GS6/TR/E	1-phase or 3-phase	5,600	24.3	230	12.2	12.2	N/A	400
Lincat	GS65	1-phase	4,500	19.6	230	N/A			
Lincat	GS6C/T	1-phase or 3-phase	4,000	17.4	230	8.7	8.7	N/A	400
Lincat	GS7	1-phase or 3-phase	6,000	26.1	230	13.0	13.0	N/A	400
Lincat	GS7/C	1-phase or 3-phase	6,000	26.1	230	13.0	13.0	N/A	400
Lincat	GS7/E	1-phase or 3-phase	7,000	30.4	230	10.1	10.1	10.1	400
Lincat	GS7/R	1-phase or 3-phase	6,000	26.1	230	13.0	13.0	N/A	400
Lincat	GS9	1-phase or 3-phase	8,600	37.4	230	12.1	12.1	13.1	400
Lincat	HT6	1-phase or 3-phase	7,000	30.4	230	8.7	13.0	8.7	400
Lincat	HT7	1-phase or 3-phase	7,000	30.4	230	8.7	13.0	8.7	400
Lincat	J12	1-phase or 3-phase	2 x 6,000	2 x 26.0	230	2 x 13.0	2 x 13.0	N/A	400
Lincat	J18	1-phase or 3-phase	2 x 9,000	2 x 39.0	230	2 x 13.0	2 x 13.0	2 x 13.0	400
Lincat	J6	1-phase or 3-phase	6,000	26.1	230	13.0	13.0	N/A	400
Lincat	J9	1-phase or 3-phase	9,000	39.1	230	13.0	13.0	13.0	400
Lincat	LCS106	3-phase	9200	N/A		14	14	14	400
Lincat	LCS110	3-phase	13800	N/A		21	21	21	400
Lincat	LCSH106	3-phase	9200	N/A		14	14	14	400
Lincat	LCSH110	3-phase	13800	N/A		21	21	21	400
Lincat	LQB16	3-phase	38200	N/A		56.7	56.7	56.7	400
Lincat	LQB6	3-phase	10300	N/A		15.5	15.5	15.5	400
Lincat	LQB6PT	3-phase	10300	N/A		15.6	15.6	15.6	400
Lincat	LQB9	3-phase	19300	N/A		28.5	28.5	28.5	400
Lincat	LQB9PT	3-phase	19300	N/A		28.6	28.6	28.6	400
Lincat	LQC106	3-phase	10300	N/A		15.5	15.5	15.5	400
Lincat	LQC106PT	3-phase	10300	N/A		15.6	15.6	15.6	400
Lincat	LQC110	3-phase	19300	N/A		28.5	28.5	28.5	400
Lincat	LQC110PT	3-phase	19300	N/A		28.6	28.6	28.6	400
Lincat	LQC120	3-phase	38200	N/A		56.7	56.7	56.7	400
Lincat	LQC206	3-phase	22300	N/A		32.8	32.8	32.8	400
Lincat	LQC210	3-phase	31300	N/A		45.9	45.9	45.9	400
Lincat	LQC220	3-phase	62200	N/A		91.3	91.3	91.3	400
Lincat	LQH106	3-phase	10300	N/A		15.5	15.5	15.5	400
Lincat	LQH106PT	3-phase	10300	N/A		15.6	15.6	15.6	400
Lincat	LQH110	3-phase	19300	N/A		28.5	28.5	28.5	400
Lincat	LQH110PT	3-phase	19300	N/A		28.6	28.6	28.6	400
Lincat	LQH120	3-phase	38200	N/A		56.7	56.7	56.7	400
Lincat	LQH206	3-phase	22300	N/A		32.8	32.8	32.8	400
Lincat	LQH210	3-phase	31300	N/A		45.9	45.9	45.9	400
Lincat	LQH220	3-phase	62200	N/A		91.3	91.3	91.3	400
Lincat	OD8006/N	1-phase or 3-phase	4,032	17.5	230	8.7	8.7	N/A	400
Lincat	OD8006/P	1-phase or 3-phase	4,032	17.8	230	8.7	8.7	N/A	400
Lincat	OD8007/N	1-phase or 3-phase	6,060	26.0	230	9.0	9.0	8.7	400
Lincat	OD8007/P	1-phase or 3-phase	6,060	26.0	230	9.0	9.0	8.7	400
Lincat	OE8008	3-phase	21,600	N/A		31.3	31.3	31.3	400
Lincat	OE8010	3-phase	14,400	N/A		17.4	22.6	22.6	400
Lincat	OE8011	3-phase	15,600	N/A		22.6	22.6	22.6	400
Lincat	OE8012	3-phase	10,400	N/A		22.6	22.6	N/A	400
Lincat	OE8015	3-phase	15,400	N/A		26.4	20.5	20.5	400
Lincat	OE8016	3-phase	21,600	N/A		31.3	31.3	31.3	400
Lincat	OE8017	3-phase	24,000	N/A		34.8	34.8	34.8	400
Lincat	OE8018	3-phase	10,600	N/A		15.3	15.3	15.3	400
Lincat	OE8019	3-phase	21,200	N/A		30.7	30.7	30.7	400
Lincat	OE8020	3-phase	10,000	N/A		14.5	14.5	14.5	400
Lincat	OE8021	3-phase	20,000	N/A		29.0	29.0	29.0	400
Lincat	OE8105	3-phase	14,000	N/A		20.3	20.3	20.3	400
Lincat	OE8105/OP	3-phase	14,000	N/A		20.3	20.3	20.3	400
Lincat	OE8105/OP2	3-phase	14,000	N/A		20.3	20.3	20.3	400

Electricity Supply Requirements

Electrical products not listed on this page are supplied for operation on a 230/240v, 13 amp supply.

Brand	Product Code	Power Supply/ Connection Type	Electrical Supply Rating [watts]	Single Phase		Three Phase				
				Amps	Voltage	Amps - Phase 1	Amps - Phase 2	Amps - Phase 3	Voltage	
Lincat	OE8108	3-phase	22,000	N/A		31.8 [1 cab]; 2 x 15.9 [2 cab]	31.8 [1 cab]; 2 x 15.9 [2 cab]	N/A		400
Lincat	OE8108/OP	3-phase	22,000	N/A		31.8 [1 cab]; 2 x 15.9 [2 cab]	31.8 [1 cab]; 2 x 15.9 [2 cab]	N/A		400
Lincat	OE8112	3-phase	12,000	N/A		17.5	17.5	17.5		400
Lincat	OE8112/OP	3-phase	12,000	N/A		17.5	17.5	17.5		400
Lincat	OE8113	3-phase	24,000	N/A		34.8 [1 cab]; 2 x 17.4 [2 cab]	34.8 [1 cab]; 2 x 17.4 [2 cab]	N/A		400
Lincat	OE8113/OP	3-phase	24,000	N/A		34.8 [1 cab]; 2 x 17.4 [2 cab]	34.8 [1 cab]; 2 x 17.4 [2 cab]	N/A		400
Lincat	OE8113/OP2	3-phase	24,000	N/A		34.8 [1 cab]; 2 x 17.4 [2 cab]	34.8 [1 cab]; 2 x 17.4 [2 cab]	N/A		400
Lincat	OE8114	3-phase	14,000	N/A		20.3	20.3	20.3		400
Lincat	OE8114/OP	3-phase	14,000	N/A		20.3	20.3	20.3		400
Lincat	OE8205	1-phase or 3-phase	8,000	34.8	230	17.4	17.4	N/A		400
Lincat	OE8205/C	1-phase or 3-phase	8,000	34.8	230	17.4	17.4	N/A		400
Lincat	OE8205/R	1-phase or 3-phase	8,000	34.8	230	17.4	17.4	N/A		400
Lincat	OE8206	1-phase or 3-phase	12,000	52.2	230	17.4	17.4	17.4		400
Lincat	OE8206/C	1-phase or 3-phase	12,000	52.2	230	17.4	17.4	17.4		400
Lincat	OE8206/R	1-phase or 3-phase	12,000	52.2	230	17.4	17.4	17.4		400
Lincat	OE8210	3-phase	17,200	N/A		28.0	28.0	18.0		400
Lincat	OE8210/FR	3-phase	17,200	N/A		28.0	28.0	18.0		400
Lincat	OE8210/R	3-phase	17,200	N/A		28.0	28.0	18.0		400
Lincat	OE8211	3-phase	8,600	N/A		10.8	21.6	10.8		400
Lincat	OE8211/R	3-phase	8,600	N/A		10.8	21.6	10.8		400
Lincat	OE8303	1-phase or 3-phase	5,400	23.50	230	11.8	11.8	N/A		400
Lincat	OE8304	1-phase	4,400	19.10	230	N/A				
Lincat	OE8306	1-phase or 3-phase	4,500	19.60	230	6.5	6.5	6.5		400
Lincat	OE8415	3-phase	7,200	N/A		16	16	16		400
Lincat	OE8416	3-phase	10,800	N/A		16	16	16		400
Lincat	OE8417	3-phase	14,400	N/A		16	16	32		400
Lincat	OE8405	3-phase	8,400	N/A		12.2	12.2	12.2		400
Lincat	OE8406	3-phase	12,400	N/A		18.0	9.0	9.0		400
Lincat	OE8413	3-phase	8,400	N/A		11.0	11.0	15.0		400
Lincat	OE8414	3-phase	13,440	N/A		15.0	22.0	22.0		400
Lincat	OE8701	1-phase or 3-phase	6,000	26.1	230	13.0	13.0	N/A		400
Lincat	P10SP6PT	3-phase	16,520	N/A		23.9	23.9	23.9		400
Lincat	P6B4	1-phase	4,950	21.5	230	N/A				
Lincat	P6B5	1-phase	5,200	22.6	230	N/A				
Lincat	P8B4	1-phase	4,900	21.5	230	N/A				
Lincat	P8B4PT	1-phase	4,900	21.5	230	N/A				
Lincat	P8B5	1-phase	5,200	22.6	230	N/A				
Lincat	P8B5PT	1-phase	5,200	22.6	230	N/A				
Lincat	P8B6	1-phase	5,200	22.6	230	N/A				
Lincat	P8B6PT	1-phase	5,200	22.6	230	N/A				
Lincat	P8SP4PT	3-phase	11,620	N/A		17.4	17.4	15.7		400
Lincat	PHEBP80	3-phase	10,000	N/A		15.1	15.1	15.1		380-415
Lincat	PHDR01/N	1-phase or 3-phase	6,000	26.1	230	8.7	8.7	8.7		400
Lincat	PHDR01/P	1-phase or 3-phase	6,000	26.1	230	8.7	8.7	8.7		400
Lincat	PHEAS01	1-phase or 3-phase	4,500	19.50	230	6.5	6.5	6.5		400
Lincat	PHEH01	16A Commando Plug	3,700	17	200	N/A				
Lincat	PHER01	3-phase	17,100	N/A		25.0	25.0	25.0		400
Lincat	PHER01/SPH	1-phase	13,000	56.5 [1 supp]; 30.4/26.1 [2 supp]	230	N/A				
Lincat	PHER02	1-phase or 3-phase	11,400	49.6	230	17.4	16.1	16.1		400
Lincat	PO425-2	1-phase or 3-phase	6,000	26.0	230	8.7	8.7	8.7		400
Lincat	PO430	1-phase or 3-phase	4,200	18.3	230	6.1	6.1	6.1		400
Lincat	PO430-2	1-phase or 3-phase	8,400	36.6	230	12.2	12.2	12.2		400
Lincat	PO630	1-phase or 3-phase	7,200	31.3	230	10.4	10.4	10.4		400
Lincat	PO630-2	3-phase	14,400	N/A		20.8	20.8	20.8		400
Lincat	PO89X	1-phase or 3-phase	5,700	24.8	230	7.6	9.6	7.6		400
Lincat	V7/4	1-phase	4,000	17.4	230	N/A				
Lincat	WMB3F/B	1-phase	3,000	13	230	N/A				
Lincat	WMB3F/W	1-phase	3,000	13	230	N/A				
Lincat	WMB5F/B	1-phase	3,000	13	230	N/A				
Lincat	WMB5F/W	1-phase	3,000	13	230	N/A				
Lincat	WMB7F/B	1-phase	3,000	13	230	N/A				
Lincat	WMB7F/W	1-phase	3,000	13	230	N/A				

All weights stated are packed weights.

Warning UK: In accordance with The Gas Safety (Installation and Use Amendment Regulations 1998) gas appliances must be installed by commercial catering equipment engineers certified by the Gas Safe Register. Failure to comply with this will render any non registered installer liable to prosecution and will invalidate the guarantee.

For Sale terms and conditions please visit lincat.co.uk/sale-terms-conditions



Touch
 FRYERS - NOW WITH

FRYER CHIEF
 PROTECTION AS
 STANDARD

frifri

2026 PRICE LIST



SPECIALISING IN

- FRYERS
- PASTA COOKERS
- CHIP SCUTTLES



Contents



Touch

For those who run the busiest professional kitchens and refuse to compromise on quality.

Professional Free Standing and Drop in Fryers with Automation

Ideally suited for:

- Multi-site operations
- Fast Food/QSR
- Education
- Healthcare
- Retail
- Cloud Kitchens

Why choose Touch?

- All the great features of Precision plus
- QPad intuitive, easy to use touchscreen

- Organise your screen to suit your operation
- 24 user set menu icons, regardless of the operator, the fryer will deliver precisely the same results every time
- Make any change with just a single touch
- Eco mode for energy savings and extended oil life

- Energy, Oil and Data Management giving you control and helping you to make informed commercial decisions
- FriFri Oil Assistant, easily monitor the condition of oil
- Fryer Chief, protection against flare-ups and fires

Find out more on page **F10**



Precision

For the chef who wants superb temperature control for consistently excellent results.

Professional Free Standing and Drop in Fryers

Ideally suited for:

- Chains
- Independents
- Gastronomy
- Education

Why choose Precision?

- Maintains oil to within +/-1°C of your required setting
- Timer with countdown display and buzzer
- Adaptive Cooking - Are there more fries than last time?

- Automatically adjusts cooking times to suit your batch size
- Integral gravity filtration
- Optional LiftFri® automatic basket lifting system
- Optional xFri® pumped oil filtration

Find out more on page **F21**



Super Easy

Outstanding value with no compromise in quality or performance.

Mid-Range Free Standing and Drop in Fryers

Ideally suited for:

- Restaurants
- Hotels
- Education
- Health

Why choose Super Easy?

- Corrosion-resistant 304 grade stainless steel pressed tanks offer superior strength and durability
- A fully rounded profile with radiused corners and a robust hinged element makes cleaning easier and quicker.

- Low watts density element with a large surface area in contact with the oil
- Available with integral gravity filtration
- Optional xFri® integrated oil pump and filtration system

Find out more on page **F31**



profi+

Professional performance from a compact, sturdy counter top fryer.

Professional Counter Top Fryers

Ideally suited for:

- Fine cuisine
- Restaurants

Why choose Profi+?

- A powerful counter top fryer capable of producing up to 25kg of chips per hour
- Highly responsive digital electronic control able to maintain oil to +/-1°C

- Rear-mounted slot-in lid that also acts as a splashback and basket support
- One piece pressed stainless steel tank with rounded corners for increased durability and reduced cleaning times

Find out more on page **F42**

All prices are exclusive of VAT.

UK
Goods are normally delivered free of charge to either the dealers' address or direct within 3 working days. If overnight and/or premium services are required charges will apply.

Export
Goods are priced ex works, export crates POA.
All FriFri is built to order and is non-cancellable.





frita+

Affordable, durable and efficient – it won't let you down.

Mid-range Counter Top Fryers

Ideally suited for:

- Cafes
- Pubs
- Restaurants

Why choose Frita+?

- A durable, efficient and well designed fryer that won't let you down

- Mechanical thermostat for maintaining oil temperature to within $\pm 8^{\circ}\text{C}$ of the temperature set
- Enhanced operator safety with front mounted control panel

- Rear-mounted slot-in lid that also acts as a splashback and basket support
- One piece pressed stainless steel tank with rounded corners for increased durability and reduced cleaning times

Find out more on page

F44



ECO

The Eco range takes up a minimum of space on work surfaces.

Budget Counter Top Fryers

Ideally suited for:

- Cafes
- Pubs
- Restaurants

Why choose Eco?

- Ideal for the supply of portions of chips, as an occasional fryer or for cooking highly flavoured food
- Mechanical thermostat for maintaining oil temperature to within $\pm 8^{\circ}\text{C}$
- One piece pressed stainless steel tank with rounded corners
- Lift-out control panel for reduced cleaning times
- Weld-free construction adds strength and durability

Find out more on page

F44



silofrit

Crisp, succulent, piping hot fries every time.

Free Standing, Built In and Counter Top Chip Scuttles

Ideally suited for:

- Quick Service Restaurants
- Restaurants

Why choose Silofrit?

- Crisp, delicious, piping hot fries every time
- Fries are kept piping hot and crispy by the infrared lamp above, as well as the drain plate with attached element beneath
- For added convenience the removable gastronorm and drain plate can be cleaned in the dishwasher
- Manufactured in durable 304 grade stainless steel

Find out more on page

F46



Super*easy pasta

Designed and built to ensure longer life in the harshest of conditions.

Pasta Cooker

Ideally suited for:

- Quick Service Restaurants
- Restaurants

Why choose the Super Easy Pasta Cooker?

- Enables you to cook all types of pasta reliably and consistently with great results
- High outputs of pasta enable you to keep pace with demand, even during peak periods
- Plumbed to fresh water supply and waste for quick, easy filling and drainage of tank
- Superior resistance to punishing salt and starch corrosion with a grade 316 stainless steel single pressed tank and corrosion resistant incoloy heating element

Find out more on page

F47





















The FriFri free standing / drop in electric fryer line up

Model	Touch	Precision	Super Easy
Temperature control			
Temperature control	Electronic +/-1°C	Electronic +/-1°C	Mechanical +/-8°C
Temperature range	30-190°C	60-190°C	90-190°C
Temperature increments	1°C	5°C	10°C
Construction			
Stainless steel grade of pressed tank	304	304	304
Stainless steel grade of body	304	304	430
Full tank cover	✓	✓	✓
Stainless steel bucket	✓	✓	✓ if gravity filtration is specified
Allergen control	✓	✓	✓
Element design	Horizontal coiled ultra low watts density element	Horizontal coiled ultra low watts density element	Low watts density element
Reversible door	✓ (Accessory)	✓ (Accessory)	✓ (Accessory)
Protection against water ingress	IPX4	IPX4	IPX4
SOLAS specification feature	Option	Option	✗
Controls			
Operation	QPad touchscreen	Touchpad	Rotary control knob
Programmes	24	1	✗
Adaptive cooking	✓	✓	✗
Eco mode	✓	✗	✗
Fryer Chief	✓	✗	✗
ColourCue traffic light fryer status	✓	✗	✗
Fat melt cycle	✓	✓	✗
Filtration			
Gravity filtration	✓	✓	Option
xFri [®] - integrated oil pump and filtration system	Option	Option	Option
LiftFri [®] - the automatic basket lifting system	Option	Option	✗
Management Tools			
Oil management	✓	✗	✗
Energy management	✓	✗	✗
Data management	✓	✗	✗
USB for updates, configuring, cloning menu, sharing	✓	✗	✗

Essential Features at a glance

Throughout the price list you will see various icons outlining the features of each FriFri model. Below is an explanation to help you identify each icon.

 Electronic Temperature Control	 Thermostatic Temperature Control	 Touchscreen Programmable Control	 xFri [®] Pumped Oil Filtration Option	 Gravity-fed Oil Filtration	 SOLAS Specification Option	 LiftFri [®] Automatic Basket Lift Option
 Horizontally Coiled Elements	 Adaptive Cooking	 Data Management	 Oil Management	 Timer	 Temperature View	 Eco Mode
 Allergen Control	 Rotary Control Front	 Rotary Control Rear	 Touchpad Control	 Fryer Chief		

The Frying Challenge



Consistency and Quality of Food

Consistency is a crucial element for any foodservice operation to maintain not only a great reputation but also returning customers. The cooking equipment specified plays a critical role in this for any operation, large or small.



Food Wastage

Between 33-50% of all food produced globally is never eaten, and the value of this wasted food is worth over \$1 trillion.

Not only are all of the resources that went into creating the uneaten food wasted but when food waste goes to landfill, it decomposes and creates methane, which is 23x more deadly than carbon dioxide.



Oil Usage

The most costly ongoing expense when operating a professional fryer is the cooking oil.

Reducing the amount of oil you use is the most cost-effective way of dealing with it. This is also the best option for the environment.



Energy Usage

Energy consumption in foodservice operation has always been high. With energy costs increasing the hospitality industry needs to adapt to reduce energy use and carbon emissions.



Limited Kitchen Space

Commercial kitchens are getting smaller. Around the world, foodservice operations are increasing profitability by shrinking kitchens and dedicating more space to front-of-house. Many new food concepts, such as pop-up restaurants and food trucks, have limited space.



Dietary Requirements and Restrictions

Meeting individual dietary requirements is a growing challenge and can be both costly to the health of your customers and also your reputation if you get it wrong. Food allergies and intolerances are at an all-time high, and as we become more multicultural as a society there is a need to cater to religious and cultural diets as well.



Consistency & Quality of Food

Quality



Horizontal Coiled Elements



Electronic Temperature Control



Adaptive Cooking



LiftFri[®] Automatic Basket Lift Option

ColourCue



Success ultimately depends on the quality and consistency of the food you produce. Deliver incredibly accurate and uniform cooking every time.

FriFri is your new kitchen assistant, helping you to deliver quality results every time.

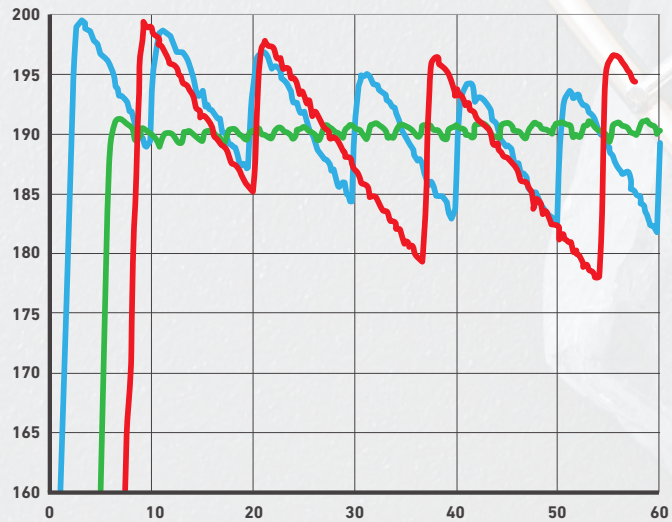

— Super Easy — Precision & Touch — Standard Electric Fryer

That all-important crunch!

Electronic temperature control, powerful elements and fast recovery, maintain oil to within $\pm 1^\circ\text{C}$ of your required setting. This prevents food from absorbing excess oil and ensures that it has that all important crunch!

Keeping your oil in peak condition!

FriFri Oil Assistant and xFri[®] pumped oil filtration enables you to easily monitor the condition of oil with the on-screen oil status bar. When prompted filter the oil even while its still hot, mid service if necessary, and resume frying in under five minutes. It is so quick and easy there is no excuse not to!

One touch perfect food!

With 24 programmed icon driven menu items, regardless of the operator, at one touch, deliver precisely the same results every time.

Are there more fries than last time?

Adaptive cooking automatically adjusts the cooking times to suit your batch size ensuring you never serve undercooked food.

Raising food to the next level

Perfect for kitchens where you don't have time for constant supervision, LiftFri[®] automatic basket lifting system lifts food at the end of the cycle to prevent overcooking.

Easy-View Traffic Light Status—ColourCue

Great for busy and noisy kitchens, ColourCue shows you the status of your fryer at a glance: **red** - attention required such as unload; **amber** - pre-heating; **green** - ready to fry.

Data driven quality

For the ultimate repeatable results view your fryer usage data - hours of operation coupled with the number of cook and filter cycles.

Consistency across sites

Ensure consistent, great quality results across multiple sites, configure and clone your menu easily via USB.

FriFri has been offering the same high quality to its customers for over 70 years



Limited Kitchen Space Dietary Requirements and Restrictions

Design

A fryer that fits in perfectly with your kitchen and your needs

Deliver big in a small space!

Offering high output from minimal footprint, with models from just 200mm wide, FriFri work wonders even in limited spaces.

FriFri - build your perfect fryer!

There is a FriFri for every type of foodservice operation; from hospitals to food trucks, to ships. From 200mm to 600mm wide, free standing on legs or castors, drop in or SOLAS, there is a fryer for you!

And it doesn't end there! Customise your fryer with a choice of power ratings, and optional features such as basket lifts and pumped filtration.

Just see our Fryer Designer below for all the options available to you!

Operation at a level to meet your needs

FriFri can be as automated as you need to support your operation, whether you require easy one Touch icon driven operation or you want to

be more hands on with your frying, there is a FriFri fryer to support your kitchen set up.

Superior build

Corrosion-resistant 304 grade stainless steel pressed tanks offer superior strength and durability - we are so confident in the life of our tanks that they come with a 10 year warranty. A fully rounded profile with radiused corners and a robust hinged element makes cleaning easier and quicker.

Safety first

Included on all Touch models as standard Fryer Chief is an essential safety feature preventing flare-ups and fires from dangerously low oil levels. Software monitors the oil level and valve mechanism to guard against human errors, such as turning on the fryer without checking the oil level or leaving the drain valve open.

Drainage for our integral filtration system is through the body of the fryer to a quick release bucket, safe and mess free. A stainless steel

bucket collects filtered oil housed within the cabinet for returning to the tank.

The xFri® integrated oil pump removes the need to manually return oil to the tank or have any contact with the hot oil, reducing the risk of spillages and accidents.

Optimum allergen control

Supplied with separate filtration systems and buckets, twin and triple tank models provide completely segregated gravity filtration for optimum allergen control or to cater for dietary preferences. To compliment this, separate xFri® pumps can be specified to achieve segregated pumped filtration.

The optional Food Segregation Management Pack (FSM) enables components and baskets which can be swapped to be colour-coded to stop them being mixed-up.

A future proofed investment

With easy to apply USB updates.

Fryer Designer

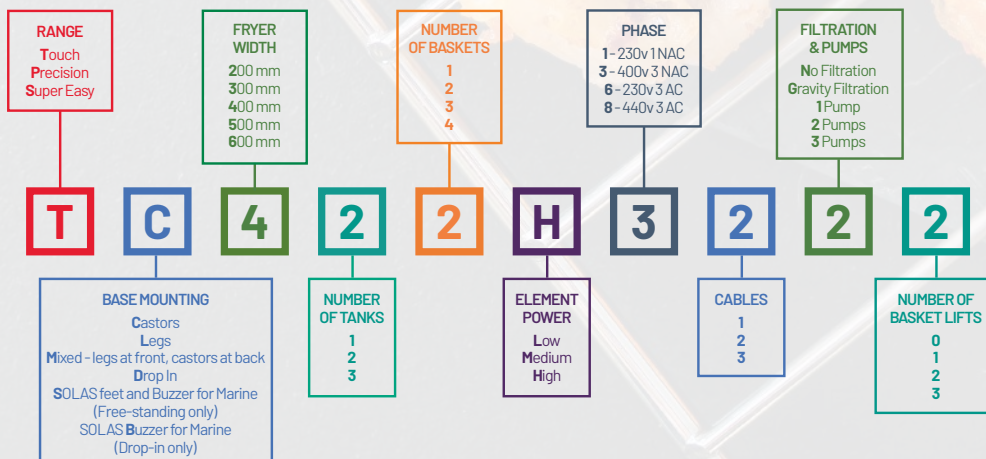



Energy Usage Food Waste Oil Usage



Eco

FriFri brings together a number of features to help you deliver your eco goals; reducing energy usage, minimising food waste and limiting oil usage.

Great delivery

A compact tank design and efficient cool zone guarantees reduced oil usage, fast heat up and a high output to oil ratio.

Fast recovery

With a greater surface contact with the oil, unique horizontally coiled elements coupled with electronic temperature control together deliver energy efficiency and faster recovery.

Eco mode

Utilising the eco mode, if the fryer is inactive for the a set period of time, it will automatically reduce to a user defined temperature. This not only delivers energy savings and extends the life of the oil and elements, it also makes for a cooler, more comfortable working environment for staff.

Insulation

Fully insulated tanks reduce heat loss.

Reduce oil usage

Extreme temperatures and carbonised food debris are two major contributors in oil degradation. Tight temperature control and the dual filtration system combined with the eco mode prolongs oil life, reduces oil usage and the volume of waste oil.

Cook what you need, when you need it

Its not just the food waste created from cooking more food than is needed, it is also the energy, oil and labour required to produce it. To minimise waste a fryer with multiple baskets can be used to fry small batches simultaneously or twin and triple tank fryers can be used to cook portions requiring different temperatures.

Zero waste just perfectly cooked food

Adaptive cooking will automatically adjust cooking times to suit your batch size to make sure you are not serving undercooked food. LiftFri® automatic basket lifting system will ensure food is not overcooked.

Sustainable design from cradle to grave

Pressed tanks remove the environmental costs of welding and the weaknesses associated with welds and joins. We are so confident in the life of our pressed tanks that they come with a 10 year warranty.

FriFri electric fryers are up to 35% more energy-efficient than a typical gas fryer



Energy Usage

Oil Usage



Oil

Success ultimately depends on the quality and consistency of the food you produce. The three enemies of oil - heat, carbon build up and oxygen - can damage oil, affecting the texture, taste and overall flavour of the food you produce. These enemies will also reduce the life of your oil, increasing your oil purchase and disposal costs.

Enemy 1 - Extreme temperatures

FriFri's heating elements have a larger surface area in contact with the oil. Gentle heat distribution across the oil's surface prevents the oil from scorching and ultimately degrading. This, together with tight temperature control ensures extended oil life.

The fat melt cycle for operations using solid fat guards against oil burn in localised areas. The elements pulse melting the fat gently.

Enemy 2 - Carbonised debris

During frying, food pieces break off, eventually becoming burnt carbonised debris. If you continue

using the oil it will affect the taste and appearance of food.

Our integral filtration system extends oil life by up to 75% saving you money on oil purchase and disposal costs. The dual filter system removes debris and carbonised particles.

Easily monitor the condition of oil with the on-screen oil status bar, once the user set life cycle has been reached Oil Assistant will prompt to drain and filter the oil.

The xFri® Integrated oil pump will filter the oil at the touch of a button, even while it's still hot, mid-service if necessary, and resume frying in under five minutes, making oil changes easy and hassle free.

Enemy 3 - Oxygen

FriFri fryers are supplied with lids so tanks can be covered when not in use.

Our integral filtration system extends oil life by up to 75% reducing oil usage



As standard

- Electronic Temperature Control
- Touchscreen Programmable Controls
- Adaptive Cooking
- Oil Management
- Eco Mode
- Gravity-fed Oil Filtration
- Data Management
- Horizontally Coiled Elements
- Allergen Control
- Fryer Chief

Optional

- xFri® Pumped Oil Filtration Option
- LiftFri® Automatic Basket Lift Option
- SOLAS Specification Option

Touch

For those who run the busiest professional kitchens and refuse to compromise on quality, Touch is your newest kitchen assistant, helping you to deliver quality results every time.

NOW WITH



Ideally suited for use in

- Multi-site operations
- Fast Food/ QSR
- Education
- Healthcare
- Retail
- Cloud Kitchens



QPad

Organise your screen to suit your operation. In the recipe manager, Touch enables you to easily set up and position 24 programmed icon driven menu items. Once set each menu icon regardless of the operator, will deliver precisely the same results every time at just one touch!

The 4.3" QPad is intuitive, easy to use and provides the wider functionality and greater control that only a touchscreen can deliver. Make any change with just a single touch.

Energy Management

Visibility into energy usage and managing energy costs has never been more critical. Touch puts you in control and helps you understand your energy usage. Customise the eco settings by defining the optimum time out and temperature to suit your operation. View where you can make savings with detailed analysis of the fryer's energy usage over the last 8 hours, 24 hours, 7 days and 28 days.

Future Proof Compact Design

Invest in the future of your business with a Touch fryer. With superior construction, an industry leading high output from minimal footprint, and with easy to apply USB software updates, Touch will ensure happy, satisfied customers for many years to come.

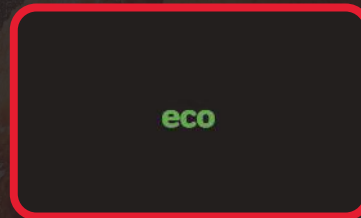
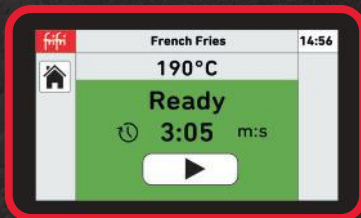

ColourCue

Easy-View Traffic Light Status - great for busy and noisy kitchens, ColourCue shows you the status of your fryer at a glance: **red** - attention required such as unload; **amber** - pre-heating; **green** - ready to fry.

eco mode

Eco mode not only delivers energy savings and extends the life of the oil and elements, it also makes for a cooler, more comfortable working environment for staff.

Adaptive Cooking

Are there more fries than last time? Automatically adjust cooking times to suit your batch size ensuring you never serve undercooked food.



Data Management

Data driven quality. For the ultimate repeatable results view your fryer usage data hours of operation coupled with the number of cook and filter cycles. For multi-site operations configure and clone your menu easily via USB.

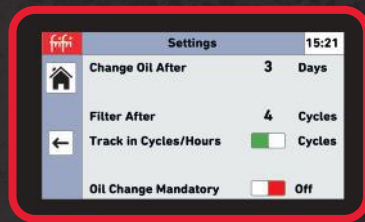

Oil Management

The most costly ongoing expense when operating a professional fryer is the cooking oil. Touch gives you complete control in managing your oil usage - specify how often, in cook cycles or hours the oil should be filtered. And to help you make informed commercial decisions about your oil usage it provides insight into how often the oil has been filtered and changed.



Oil Assistant

FriFri Oil Assistant enables you to easily monitor the condition of oil with the on-screen oil status bar.



Fryer Chief

Fryer Chief is an essential safety feature which monitors oil levels and detects low levels to prevent flare-ups and fires, protecting operators and customers from harm while also safeguarding the fryer and premises from potential costly fire damage and associated downtime.

Software monitors the oil level and valve mechanism to guard against human errors, such as turning on the fryer without checking the oil level or leaving the drain valve open.

If Fryer Chief is triggered operators are presented with easy-to-understand instructions to enable them to get the fryer back up and running safely.

Optional



xFri® Pumped Oil Filtration Option

xFri® filters oil at the push of a button and returns the cleaned oil to the tank. You can filter the oil safely while it's still hot, mid-service if necessary, and resume frying in under five minutes.



Allergen Control

For optimum oil segregation, fryers with two or three tanks can be supplied with separate oil pumps.



LiftFri® Automatic Basket Lift Option

Great for kitchens where you don't have time for constant supervision, LiftFri® automatic basket lifting system lifts food at the end of the cycle to prevent overcooking.

For the operator who needs automation



Touch 422 built-in

Touch 211

Touch 311











Touch 633

Touch



NOW WITH

FRYER CHIEF
 PROTECTION AS STANDARD

As standard

- 
Electronic Temperature Control
- 
Touchscreen Programmable Controls
- 
Adaptive Cooking
- 
Oil Management
- 
Eco Mode
- 
Gravity-fed Oil Filtration
- 
Data Management
- 
Horizontally Coiled Elements
- 
Allergen Control
- 
Fryer Chief

Optional

- 
xFri[®] Pumped Oil Filtration Option
- 
LiftFri[®] Automatic Basket Lift Option
- 
SOLAS Specification Option

Touch Single Tank Free Standing Fryers



Lincat

211 Single tank electric fryer (200mm wide)						
OIL CAPACITY	NO. OF TANKS	NO. OF BASKETS	DIMENSIONS (mm)			NET WT
			H	W	D	
7.5-9 L	1	1	994	197.5	650	47

MODEL	PRICE £	PRICE €	POWER	OUTPUT /HR (kg)**	PHASE	SUPPLY CABLES
*TL211L31G0	£5015	€5768	7.5kW	18	3	1
*TL211L11G0	£5015	€5768	7.5kW	18	1	1
*TL211M31G0	£5076	€5839	9kW	20	3	1
*TL211M11G0	£5076	€5839	9kW	20	1	1
*TL211H31G0	£5144	€5917	11kW	22	3	1

	PRICE £	PRICE €	DESCRIPTION
O*	£2422	€2786	Single oil return pump
O*	£1728	€1987	Single auto basket lift
O*	£293	€338	SOLAS option for single tank free-standing

	MODEL	PRICE £	PRICE €	DESCRIPTION
A	FRIFRI/USB	£31	€36	USB Stick



Lincat

311 Single tank electric fryer (300mm wide)						
OIL CAPACITY	NO. OF TANKS	NO. OF BASKETS	DIMENSIONS (mm)			NET WT
			H	W	D	
12.5-14.5 L	1	1 (2)***	994	297.5	650	56

MODEL	PRICE £	PRICE €	POWER	OUTPUT /HR (kg)**	PHASE	SUPPLY CABLES
*TL311L31G0	£5566	€6401	11.4kW	28.5	3	1
*TL311H31G0	£5645	€6493	15kW	32	3	1

	PRICE £	PRICE €	DESCRIPTION
O*	£2422	€2786	Single oil return pump
O*	£1728	€1987	Single auto basket lift
O*	£186	€213	Two rear castors (fixed)
O*	£370	€425	Four castors (fixed castors at rear)
O*	£293	€338	SOLAS option for single tank free-standing

	MODEL	PRICE £	PRICE €	DESCRIPTION
A	FZ301093	£140	€161	Small baskets for 300mm wide single tank
A	FRIFRI/USB	£31	€36	USB Stick

** 7mm Frozen Fries

*** No. of baskets shown in brackets are an available option. Please call for more details

O* Factory fitted option please request at point of ordering

† 412 pricing applies

* Please refer to pages F48 to F50 for electricity supply requirements



Fryer Designer

Touch

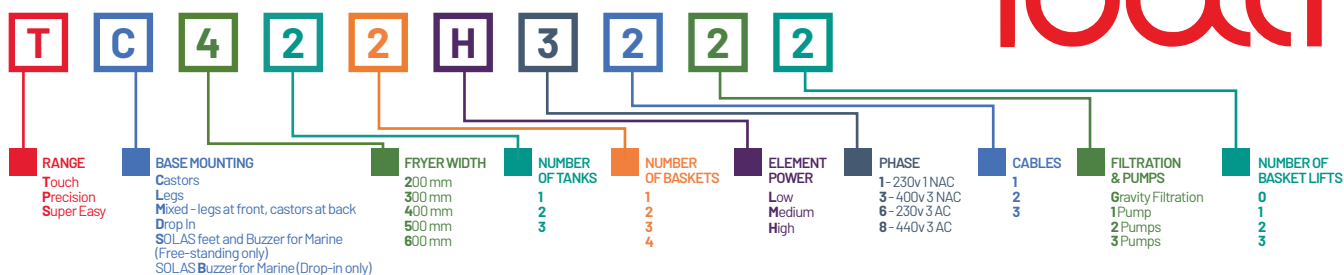

The models in the table are for base models supplied on legs, without pumped oil filtration or basket lifts.

Do you want an alternative configuration of baskets? **How many** supply cables would you like?
Do you require chargeable add on items such as castors and pumped oil filtration?

Please use our Fryer Designer to create your bespoke code. If you would like help to create code please **call us on 01522 875500**.

Touch Single Tank Free Standing Fryers



Lincat

411 Single tank electric fryer (400mm wide)						
OIL CAPACITY	NO. OF TANKS	NO. OF BASKETS	DIMENSIONS (mm)			NET WT
			H	W	D	
17-20.5 L	1	1	994	397.5	650	69

MODEL	PRICE £	PRICE €	POWER	OUTPUT /HR (kg)**	PHASE	SUPPLY CABLES
*TL411L31G0	£6410	€7372	15kW	36	3	1
*TL411M31G0	£6534	€7515	18kW	40	3	1
*TL411H31G0	£6664	€7664	22kW	44	3	1

	PRICE £	PRICE €	DESCRIPTION
0*	£2422	€2786	Single oil return pump
0*	£1728	€1987	Single auto basket lift
0*	£186	€213	Two rear castors (fixed)
0*	£370	€425	Four castors (fixed castors at rear)
0*	£293	€338	SOLAS option for single tank free-standing

	MODEL	PRICE £	PRICE €	DESCRIPTION
A	FZ411048	£185	€214	Large basket for 400mm wide single tank
A	FRIFRI/USB	£31	€36	USB Stick



Lincat

412 Single tank electric fryer (400mm wide)						
OIL CAPACITY	NO. OF TANKS	NO. OF BASKETS	DIMENSIONS (mm)			NET WT
			H	W	D	
17-20.5 L	1	2 (1)***	994	397.5	650	69

MODEL	PRICE £	PRICE €	POWER	OUTPUT /HR (kg)**	PHASE	SUPPLY CABLES
*TL412L31G0	£6410	€7372	15kW	36	3	1
*TL412M31G0	£6534	€7516	18kW	40	3	1
*TL412H31G0	£6664	€7664	22kW	44	3	1

	PRICE £	PRICE €	DESCRIPTION
0*	£2422	€2786	Single oil return pump
0*	£1728	€1987	Single auto basket lift
0*	£3453	€3971	Twin auto basket lift
0*	£186	€213	Two rear castors (fixed)
0*	£370	€425	Four castors (fixed castors at rear)
0*	£293	€338	SOLAS option for single tank free-standing

	MODEL	PRICE £	PRICE €	DESCRIPTION
A	FZ411048	£185	€214	Large basket for 400mm wide single tank
A	FRIFRI/USB	£31	€36	USB Stick

** 7mm Frozen Fries

*** No. of baskets shown in brackets are an available option. Please call for more details

* Please refer to pages F48 to F50 for electricity supply requirements

0* Factory fitted option please request at point of ordering



Touch

NOW WITH



PROTECTION AS STANDARD

As standard

- Electronic Temperature Control
- Touchscreen Programmable Controls
- Adaptive Cooking
- Oil Management
- Eco Mode
- Gravity-fed Oil Filtration
- Data Management
- Horizontally Coiled Elements
- Allergen Control
- Fryer Chief

Optional

- xFri[®] Pumped Oil Filtration Option
- LiftFri[®] Automatic Basket Lift Option
- SOLAS Specification Option

Touch Twin Tank Free Standing Fryers



Lincat

422 Twin tank electric fryer (400mm wide)						
OIL CAPACITY	NO. OF TANKS	NO. OF BASKETS	DIMENSIONS (mm)			NET WT
			H	W	D	
2 x 7.5-9 L	2	2	994	397.5	650	79

MODEL	PRICE £	PRICE €	POWER	OUTPUT /HR (kg)**	PHASE	SUPPLY CABLES
*TL422L32G0	£9462	€10,882	2x7.5kW	2 x 18	3	2
*TL422L12G0	£9462	€10,882	2x7.5kW	2 x 18	1	2
*TL422L31G0	£9462	€10,882	2x7.5kW	2 x 18	3	1
*TL422M32G0	£9594	€11,034	2 x 9kW	2 x 20	3	2
*TL422M12G0	£9594	€11,034	2 x 9kW	2 x 20	1	2
*TL422M31G0	£9594	€11,034	2 x 9kW	2 x 20	3	1
*TL422H32G0	£9724	€11,184	2 x 11kW	2 x 22	3	2
*TL422H31G0	£9724	€11,184	2 x 11kW	2 x 22	3	1

	PRICE £	PRICE €	DESCRIPTION
0*	£2422	€2786	Single oil return pump
0*	£4838	€5564	Twin oil return pump
0*	£1728	€1987	Single auto basket lift
0*	£3453	€3971	Twin auto basket lift
0*	£186	€213	Two rear castors (fixed)
0*	£370	€425	Four castors (fixed castors at rear)
0*	£476	€547	SOLAS option for twin tank free-standing

MODEL	PRICE £	PRICE €	DESCRIPTION
A FRIFRI/USB	£31	€36	USB Stick

** 7mm Frozen Fries

*** No. of baskets shown in brackets are an available option. Please call for more details

0* Factory fitted option please request at point of ordering

† 412 pricing applies



Lincat

622 Twin tank electric fryer (600mm wide)						
OIL CAPACITY	NO. OF TANKS	NO. OF BASKETS	DIMENSIONS (mm)			NET WT
			H	W	D	
2x12.5-14.5L	2	2 (3,4)***	994	592	650	99

MODEL	PRICE £	PRICE €	POWER	OUTPUT /HR (kg)**	PHASE	SUPPLY CABLES
*TL622L32G0	£10,834	€12,482	2x11.4kW	2x26.5	3	2
*TL622L31G0	£10,834	€12,482	2x11.4kW	2x26.5	3	1
*TL622H32G0	£11,012	€12,665	2 x 15kW	2x26.5	3	2
*TL622H31G0	£11,012	€12,665	2 x 15kW	2x26.5	3	1

	PRICE £	PRICE €	DESCRIPTION
0*	£2422	€2786	Single oil return pump
0*	£4838	€5564	Twin oil return pump
0*	£1728	€1987	Single auto basket lift
0*	£3453	€3971	Twin auto basket lift
0*	£186	€213	Two rear castors (fixed)
0*	£370	€425	Four castors (fixed castors at rear)
0*	£476	€547	SOLAS option for twin tank free-standing

MODEL	PRICE £	PRICE €	DESCRIPTION
A FZ301093	£140	€161	Small baskets for 600mm wide twin tank
A FRIFRI/USB	£31	€36	USB Stick

* Please refer to pages F48 to F50 for electricity supply requirements



Fryer Designer

Touch

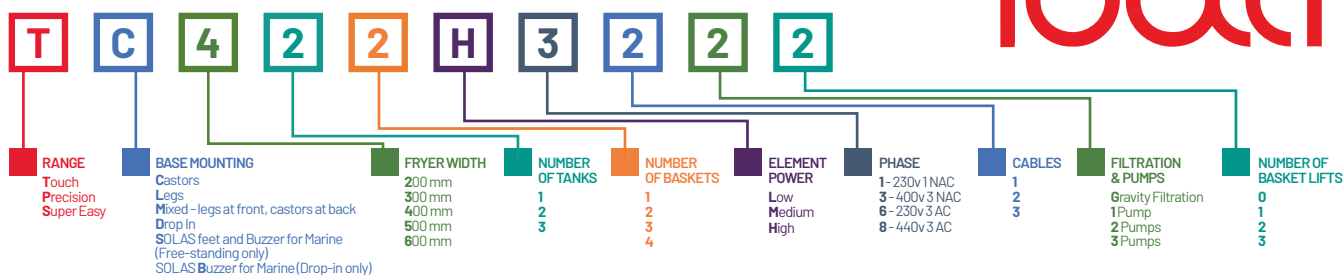

The models in the table are for base models supplied on legs, without pumped oil filtration or basket lifts.

Do you want an alternative configuration of baskets? **How many** supply cables would you like?
Do you require chargeable add on items such as castors and pumped oil filtration?

Please use our Fryer Designer to create your bespoke code. If you would like help to create code please **call us on 01522 875500**.

Touch Triple Tank Free Standing Fryers



Lincat

633 Triple tank electric fryer (600mm wide)

OIL CAPACITY	NO. OF TANKS	NO. OF BASKETS	DIMENSIONS (mm)			NET WT
			H	W	D	
3 x 7.5-9L	3	3	994	592	650	99

MODEL	PRICE £	PRICE €	POWER	OUTPUT /HR (kg)**	PHASE	SUPPLY CABLES
*TL633L31G0	£14,347	€16,499	3x7.5kW	3 x 18	3	1
*TL633L33G0	£14,347	€16,499	3x7.5kW	3 x 18	3	3
*TL633L13G0	£14,347	€16,499	3x7.5kW	3 x 18	1	3
*TL633M31G0	£14,435	€16,600	3 x 9kW	3 x 20	3	1
*TL633M33G0	£14,435	€16,600	3 x 9kW	3 x 20	3	3
*TL633M13G0	£14,435	€16,600	3 x 9kW	3 x 20	1	3
*TL633H33G0	£14,859	€17,084	3 x 11kW	3 x 22	3	3
*TL633H31G0	£14,859	€17,084	3 x 11kW	3 x 22	3	1

	PRICE £	PRICE €	DESCRIPTION
O*	£2422	€2786	Single oil return pump
O*	£7021	€8075	Triple oil return pump
O*	£1728	€1987	Single auto basket lift
O*	£3453	€3971	Twin auto basket lift
O*	£5365	€6170	Triple auto basket lift
O*	£186	€213	Two rear castors (fixed)
O*	£370	€425	Four castors (fixed castors at rear)
O*	£657	€756	SOLAS option for triple tank free-standing

MODEL	PRICE £	PRICE €	DESCRIPTION
A FRIFRI/USB	£31	€36	USB Stick

** 7mm Frozen Fries

*** No. of baskets shown in brackets are an available option. Please call for more details

O* Factory fitted option please request at point of ordering

* Please refer to pages F48 to F50 for electricity supply requirements

Touch

NOW WITH



As standard

- Electronic Temperature Control
- Touchscreen Programmable Controls
- Adaptive Cooking
- Oil Management
- Eco Mode
- Gravity-fed Oil Filtration
- Data Management
- Horizontally Coiled Elements
- Allergen Control
- Fryer Chief

Optional

- xFri[®] Pumped Oil Filtration Option
- LiftFri[®] Automatic Basket Lift Option
- SOLAS Specification Option

Touch Single Tank Drop In Fryers



Lincat

211 Single tank electric fryer (200mm wide)						
OIL CAPACITY	NO. OF TANKS	NO. OF BASKETS	DIMENSIONS (mm)			NET WT
			H	W	D	
7.5-9 L	1	1	809	197.5	630	40



Lincat

311 Single tank electric fryer (300mm wide)						
OIL CAPACITY	NO. OF TANKS	NO. OF BASKETS	DIMENSIONS (mm)			NET WT
			H	W	D	
12.5-14.5 L	1	1 (2)***	809	297.5	630	47

MODEL	PRICE £	PRICE €	POWER	OUTPUT /HR (kg)**	PHASE	SUPPLY CABLES
*TD211L31G0	£4915	€5653	7.5kW	18	3	1
*TD211L11G0	£4915	€5653	7.5kW	18	1	1
*TD211M31G0	£4975	€5722	9kW	20	3	1
*TD211M11G0	£4975	€5722	9kW	20	1	1
*TD211H31G0	£5042	€5800	11kW	22	3	1

MODEL	PRICE £	PRICE €	POWER	OUTPUT /HR (kg)**	PHASE	SUPPLY CABLES
*TD311L31G0	£5441	€6258	11.4kW	28.5	3	1
*TD311H31G0	£5520	€6348	15kW	32	3	1

	PRICE £	PRICE €	DESCRIPTION
0*	£2422	€2786	Single oil return pump
0*	£1728	€1987	Single auto basket lift
0*	£293	€338	SOLAS option for single tank drop in

	PRICE £	PRICE €	DESCRIPTION
0*	£2422	€2786	Single oil return pump
0*	£1728	€1987	Single auto basket lift
0*	£293	€338	SOLAS option for single tank drop in

MODEL	PRICE £	PRICE €	DESCRIPTION
A FRIFRI/USB	£31	€36	USB Stick

MODEL	PRICE £	PRICE €	DESCRIPTION
A FZ301093	£140	€161	Small baskets for 311
A FRIFRI/USB	£31	€36	USB Stick



** 7mm Frozen Fries

*** No. of baskets shown in brackets are an available option. Please call for more details

0* Factory fitted option please request at point of ordering

* Please refer to pages F48 to F50 for electricity supply requirements

Fryer Designer

Touch

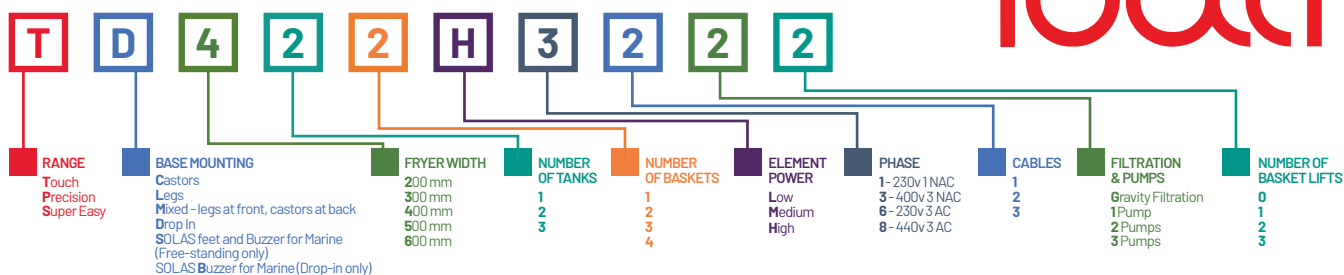

The models in the table are for base models supplied on legs, without pumped oil filtration or basket lifts.

Do you want an alternative configuration of baskets? **How many** supply cables would you like?
Do you require chargeable add on items such as castors and pumped oil filtration?

Please use our Fryer Designer to create your bespoke code. If you would like help to create code please **call us on 01522 875500**.

Touch Single Tank Drop In Fryers



Lincat

411 Single tank electric fryer (400mm wide)

OIL CAPACITY	NO. OF TANKS	NO. OF BASKETS	DIMENSIONS (mm)			NET WT
			H	W	D	
17-20.5 L	1	2 (1)**	809	397.5	630	62

MODEL	PRICE £	PRICE €	POWER	OUTPUT /HR (kg)**	PHASE	SUPPLY CABLES
*TD411L31G0	£6257	€7508	15kW	36	3	1
*TD411M31G0	£6383	€7342	18kW	40	3	1
*TD411H31G0	£6510	€7486	22kW	44	3	1

	PRICE £	PRICE €	DESCRIPTION
0*	£2422	€2786	Single oil return pump
0*	£1728	€1987	Single auto basket lift
0*	£293	€338	SOLAS option for single tank drop in

	MODEL	PRICE £	PRICE €	DESCRIPTION
A	FZ411048	£185	€214	Large basket for 400mm wide single tank
A	FRIFRI/USB	£31	€36	USB Stick



Lincat

412 Single tank electric fryer (400mm wide)

OIL CAPACITY	NO. OF TANKS	NO. OF BASKETS	DIMENSIONS (mm)			NET WT
			H	W	D	
17-20.5 L	1	2 (1)**	809	397.5	630	62

MODEL	PRICE £	PRICE €	POWER	OUTPUT /HR (kg)**	PHASE	SUPPLY CABLES
*TD412L31G0	£6257	€7508	15kW	36	3	1
*TD412M31G0	£6383	€7342	18kW	40	3	1
*TD412H31G0	£6510	€7486	22kW	44	3	1

	PRICE £	PRICE €	DESCRIPTION
0*	£2422	€2786	Single oil return pump
0*	£1728	€1987	Single auto basket lift
0*	£3453	€3971	Twin auto basket lift
0*	£293	€338	SOLAS option for single tank drop in

	MODEL	PRICE £	PRICE €	DESCRIPTION
A	FZ411048	£185	€214	Large basket for 400mm wide single tank
A	FRIFRI/USB	£31	€36	USB Stick



** 7mm Frozen Fries

*** No. of baskets shown in brackets are an available option. Please call for more details

0* Factory fitted option please request at point of ordering











* Please refer to pages F48 to F50 for electricity supply requirements

Touch



NOW WITH

FRYER CHIEF
 PROTECTION AS STANDARD

As standard

- 
Electronic Temperature Control
- 
Touchscreen Programmable Controls
- 
Adaptive Cooking
- 
Oil Management
- 
Eco Mode
- 
Gravity-fed Oil Filtration
- 
Data Management
- 
Horizontally Coiled Elements
- 
Allergen Control
- 
Fryer Chief

Optional

- 
xFri[®] Pumped Oil Filtration Option
- 
LiftFri[®] Automatic Basket Lift Option
- 
SOLAS Specification Option

Touch Twin Tank Drop In Fryers



Lincat

422 Twin tank electric fryer (400mm wide)						
OIL CAPACITY	NO. OF TANKS	NO. OF BASKETS	DIMENSIONS (mm)			NET WT
			H	W	D	
2 x 7.5-9 L	2	2	809	397.5	630	68



Lincat

522 Twin tank electric fryer (500mm wide)						
OIL CAPACITY	NO. OF TANKS	NO. OF BASKETS	DIMENSIONS (mm)			NET WT
			H	W	D	
1 x 12.5-14.5 + 1 x 7.5-9 L	2	2 (3)**	809	495	630	87

MODEL	PRICE £	PRICE €	POWER	OUTPUT /HR (kg)**	PHASE	SUPPLY CABLES
*TD422L32G0	£9284	€10,678	2x7.5kW	2 x 18	3	2
*TD422L12G0	£9284	€10,678	2x7.5kW	2 x 18	1	2
*TD422L31G0	£9284	€10,678	2x7.5kW		3	1
*TD422M32G0	£9416	€10,829	2 x 9kW	2 x 20	3	2
*TD422M12G0	£9416	€10,829	2 x 9kW	2 x 20	1	2
*TD422M31G0	£9416	€10,829	2 x 9kW	2 x 20	3	1
*TD422H32G0	£9545	€10,977	2 x 11kW	2 x 22	3	2
*TD422H31G0	£9545	€10,977	2 x 11kW	2 x 22	3	1

MODEL	PRICE £	PRICE €	POWER	OUTPUT /HR (kg)**	PHASE	SUPPLY CABLES
*TD522L32G0	£9842	€11,318	11.4+7.5kW	28.5 + 18	3	2
*TD522M32G0	£9909	€11,396	11.4+9kW	28.5 + 20	3	2

PRICE £	PRICE €	DESCRIPTION
0* £2422	€2986	Single oil return pump
0* £4838	€5564	Twin oil return pump
0* £1728	€1987	Single auto basket lift
0* £3453	€3971	Twin auto basket lift
0* £476	€547	SOLAS option for twin tank drop in

PRICE £	PRICE €	DESCRIPTION
0* £2422	€2786	Single oil return pump
0* £4838	€5564	Twin oil return pump
0* £1728	€1987	Single auto basket lift
0* £3453	€3971	Twin auto basket lift
0* £476	€547	SOLAS option for twin tank drop in

MODEL	PRICE £	PRICE €	DESCRIPTION
A FRIFRI/USB	£31	€36	USB Stick

MODEL	PRICE £	PRICE €	DESCRIPTION
A FZ301093	£140	€161	Small baskets for large tank
A FRIFRI/USB	£31	€36	USB Stick



** 7mm Frozen Fries

*** No. of baskets shown in brackets are an available option. Please call for more details

0* Factory fitted option please request at point of ordering

* Please refer to pages F48 to F50 for electricity supply requirements

Fryer Designer

Touch

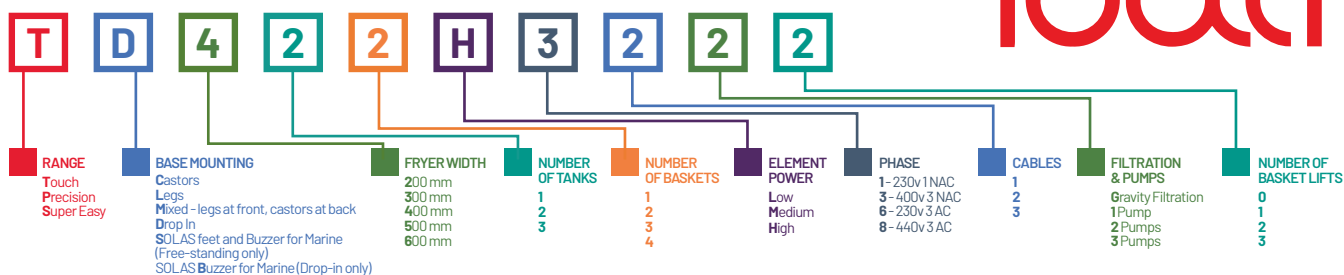

The models in the table are for base models supplied on legs, without pumped oil filtration or basket lifts.

Do you want an alternative configuration of baskets? **How many** supply cables would you like?
Do you require chargeable add on items such as castors and pumped oil filtration?

Please use our Fryer Designer to create your bespoke code. If you would like help to create code please **call us on 01522 875500**.

Touch Twin Tank Drop In Fryers



Lincat

622 Twin tank electric fryer (600mm wide)

OIL CAPACITY	NO. OF TANKS	NO. OF BASKETS	DIMENSIONS (mm)			NET WT
			H	W	D	
2x12.5-14.5L	2	2 (3,4)***	809	592	630	94

MODEL	PRICE £	PRICE €	POWER	OUTPUT /HR (kg)**	PHASE	SUPPLY CABLES
*TD622L32G0	£10,582	€12,170	2x11.4kW	2x26.5	3	2
*TD622L31G0	£10,582	€12,170	2x11.4kW	2x26.5	3	1
*TD622H32G0	£10,741	€12,352	2 x 15kW	2x26.5	3	2
*TD622H31G0	£10,741	€12,352	2 x 15kW	2x26.5	3	1

	PRICE £	PRICE €	DESCRIPTION
O*	£2422	€2786	Single oil return pump
O*	£4838	€5564	Twin oil return pump
O*	£1728	€1987	Single auto basket lift
O*	£3453	€3971	Twin auto basket lift
O*	£476	€547	SOLAS option for twin tank drop in

	MODEL	PRICE £	PRICE €	DESCRIPTION
A	FZ301093	£140	€161	Small baskets for 622
A	FRIFRI/USB	£31	€36	USB Stick

** 7mm Frozen Fries

*** No. of baskets shown in brackets are an available option. Please call for more details

* Please refer to pages F48 to F50 for electricity supply requirements

O* Factory fitted option please request at point of ordering



Touch

NOW WITH



As standard

- Electronic Temperature Control
- Touchscreen Programmable Controls
- Adaptive Cooking
- Oil Management
- Eco Mode
- Gravity-fed Oil Filtration
- Data Management
- Horizontally Coiled Elements
- Allergen Control
- Fryer Chief

Optional

- xFri[®] Pumped Oil Filtration Option
- LiftFri[®] Automatic Basket Lift Option
- SOLAS Specification Option

Touch Triple Tank Tank Drop In Fryers



600mm wide triple tank fryer
EXCLUSIVE TO FRIFRI
• Allergen Control
• Flexibility

Lincat

633 Triple tank electric fryer (600mm wide)						
OIL CAPACITY	NO. OF TANKS	NO. OF BASKETS	DIMENSIONS (mm)			NET WT
			H	W	D	
3 x 7.5-9 L	3	3	809	592	630	94

MODEL	PRICE £	PRICE €	POWER	OUTPUT /HR (kg)**	PHASE	SUPPLY CABLES
*TD633L31G0	£13,655	€15,704	3 x 7.5kW	3 x 18	3	1
*TD633L33G0	£13,655	€15,704	3 x 7.5kW	3 x 18	3	3
*TD633L13G0	£13,655	€15,704	3 x 7.5kW	3 x 18	1	3
*TD633M31G0	£13,856	€15,935	3 x 9kW	3 x 20	3	1
*TD633M33G0	£13,856	€15,935	3 x 9kW	3 x 20	3	3
*TD633M13G0	£13,856	€15,935	3 x 9kW	3 x 20	1	3
*TD633H33G0	£14,163	€16,288	3 x 11kW	3 x 22	3	3
*TD633H31G0	£14,163	€16,288	3 x 11kW	3 x 22	3	1

	PRICE £	PRICE €	DESCRIPTION
O*	£2422	€2786	Single oil return pump
O*	£7021	€8075	Triple oil return pump
O*	£1728	€1987	Single auto basket lift
O*	£3453	€3971	Twin auto basket lift
O*	£5365	€6170	Triple auto basket lift
O*	£657	€756	SOLAS option for triple tank drop in

** 7mm Frozen Fries

*** No. of baskets shown in brackets are an available option. Please call for more details

O* Factory fitted option please request at point of ordering

* Please refer to pages F48 to F50 for electricity supply requirements



As standard

Optional



Electronic Temperature Control



Touchpad Control



Timer



Temperature View



Adaptive Cooking



Gravity-fed Oil Filtration



Horizontally Coiled Elements



Allergen Control



xFri® Pumped Oil Filtration Option



LiftFri® Automatic Basket Lift Option



SOLAS Specification Option

Precision

For the chef who wants superb temperature control for consistently excellent results, Precision is the fryer of choice.

Ideally suited for use in



Chains



Independents



Gastronomy



Education



Electronic Temperature Control

Electronic temperature control and powerful elements always maintain oil to within +/-1 °C of your required setting, reducing oil absorption and ensuring your food always has that all-important crunch. The LED display shows the current oil temperature throughout the cook cycle.



Timer

Set the timer and see the display count down, with the buzzer sounding at the end of the cook cycle.

If the fryer has LiftFri the basket will automatically lower when the oil has reached the correct temperature. At the end of the cook cycle, the buzzer will sound and the basket will rise from the oil. The LED display will then reset to show the set time for the next batch. Perfect for when you want to cook the same product time after time, to the same exacting standards.



Temperature View

Temperature view shows you the current oil temperature, enabling you to make an informed decision as to when to start cooking.



Adaptive Cooking

Are there more fries than last time? Automatically adjust cooking times to suit your batch size ensuring you never serve undercooked food.



Gravity-fed Oil Filtration

Our integral filtration system extends oil life by up to 75% saving you money on oil purchase and disposal costs. The dual filter system removes debris and carbonised particles.



Precision 211 drop-in

Optional



xFri® Pumped Oil Filtration Option

xFri® filters oil at the push of a button and returns the cleaned oil to the tank. You can filter the oil safely while it's still hot, mid-service if necessary, and resume frying in under five minutes.



Allergen Control

For optimum oil segregation, fryers with two or three tanks can be supplied with separate oil pumps.



LiftFri® Automatic Basket Lift Option

Great for kitchens where you don't have time for constant supervision, LiftFri® automatic basket lifting system lifts food at the end of the cycle to prevent overcooking.



Precision 633



Precision

As standard



Electronic Temperature Control



Touchpad Control



Timer



Temperature View



Adaptive Cooking



Gravity-fed Oil Filtration



Horizontally Coiled Elements



Allergen Control

Optional



xFri[®] Pumped Oil Filtration Option



LiftFri[®] Automatic Basket Lift Option



SOLAS Specification Option

Precision Single Tank Free Standing Fryers



211 Single tank electric fryer (200mm wide)

OIL CAPACITY	NO. OF TANKS	NO. OF BASKETS	DIMENSIONS (mm)			NET WT
			H	W	D	
7.5-9 L	1	1	994	197.5	650	47

311 Single tank electric fryer (300mm wide)

OIL CAPACITY	NO. OF TANKS	NO. OF BASKETS	DIMENSIONS (mm)			NET WT
			H	W	D	
12.5-14.5 L	1	1 (2)***	994	297.5	650	56

MODEL	PRICE £	PRICE €	POWER	OUTPUT /HR (kg)**	PHASE	SUPPLY CABLES
*PL211L31G0	£4260	€4899	7.5kW	18	3	1
*PL211L11G0	£4260	€4899	7.5kW	18	1	1
*PL211M31G0	£4332	€4983	9kW	20	3	1
*PL211M11G0	£4332	€4983	9kW	20	1	1
*PL211H31G0	£4401	€5063	11kW	22	3	1

MODEL	PRICE £	PRICE €	POWER	OUTPUT /HR (kg)**	PHASE	SUPPLY CABLES
*PL311L31G0	£5091	€5854	11.4kW	28.5	3	1
*PL311H31G0	£5174	€5951	15kW	32	3	1

	PRICE £	PRICE €	DESCRIPTION
0*	£2422	€2786	Single oil return pump
0*	£1728	€1987	Single auto basket lift
0*	£293	€338	SOLAS option for single tank free-standing

	PRICE £	PRICE €	DESCRIPTION
0*	£2422	€2786	Single oil return pump
0*	£1728	€1987	Single auto basket lift
0*	£186	€213	Two rear castors (fixed)
0*	£370	€424	Four castors (fixed castors at rear)
0*	£293	€338	SOLAS option for single tank free-standing

	MODEL	PRICE £	PRICE €	DESCRIPTION
A	FZ301093	£140	€151	Small baskets for 300mm wide single tank

** 7mm Frozen Fries

*** No. of baskets shown in brackets are an available option. Please call for more details

0* Factory fitted option please request at point of ordering

† 412 pricing applies

* Please refer to pages F48 to F50 for electricity supply requirements



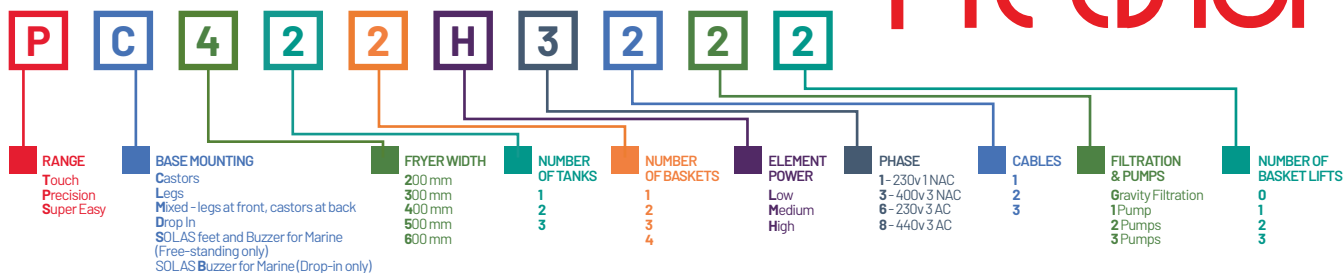

The models in the table are for base models supplied on legs, without pumped oil filtration or basket lifts.

Do you want an alternative configuration of baskets? **How many** supply cables would you like?
Do you require chargeable add on items such as castors and pumped oil filtration?

Please use our Fryer Designer to create your bespoke code. If you would like help to create code please **call us on 01522 875500**.

Precision Single Tank Free Standing Fryers



411 Single tank electric fryer (400mm wide)

OIL CAPACITY	NO. OF TANKS	NO. OF BASKETS	DIMENSIONS (mm)			NET WT
			H	W	D	
17-20.5 L	1	2 (1)**	994	397.5	650	69

412 Single tank electric fryer (400mm wide)

OIL CAPACITY	NO. OF TANKS	NO. OF BASKETS	DIMENSIONS (mm)			NET WT
			H	W	D	
17-20.5 L	1	2 (1)**	994	397.5	650	69

MODEL	PRICE £	PRICE €	POWER	OUTPUT /HR (kg)**	PHASE	SUPPLY CABLES
*PL411L31G0	£5895	€6780	15kW	36	3	1
*PL411M31G0	£6037	€6943	18kW	40	3	1
*PL411H31G0	£6178	€7105	22kW	44	3	1

MODEL	PRICE £	PRICE €	POWER	OUTPUT /HR (kg)**	PHASE	SUPPLY CABLES
*PL412L31G0	£5895	€6780	15kW	36	3	1
*PL412M31G0	£6037	€6943	18kW	40	3	1
*PL412H31G0	£6178	€7106	22kW	44	3	1

	PRICE £	PRICE €	DESCRIPTION
O*	£2422	€2786	Single oil return pump
O*	£1728	€1987	Single auto basket lift
O*	£186	€213	Two rear castors (fixed)
O*	£370	€424	Four castors (fixed castors at rear)
O*	£293	€338	SOLAS option for single tank free-standing

	PRICE £	PRICE €	DESCRIPTION
O*	£2422	€2786	Single oil return pump
O*	£1728	€1987	Single auto basket lift
O*	£186	€213	Two rear castors (fixed)
O*	£370	€424	Four castors (fixed castors at rear)
O*	£293	€338	SOLAS option for single tank free-standing

MODEL	PRICE £	PRICE €	DESCRIPTION
A FZ411048	£185	€214	Large basket for 400mm wide single tank

MODEL	PRICE £	PRICE €	DESCRIPTION
A FZ411048	£185	€214	Large basket for 400mm wide single tank

** 7mm Frozen Fries

*** No. of baskets shown in brackets are an available option. Please call for more details

* Please refer to pages F48 to F50 for electricity supply requirements

O* Factory fitted option please request at point of ordering



Precision

As standard



Electronic Temperature Control



Touchpad Control



Timer



Temperature View



Adaptive Cooking



Gravity-fed Oil Filtration



Horizontally Coiled Elements



Allergen Control

Optional



xFri[®] Pumped Oil Filtration Option



LiftFri[®] Automatic Basket Lift Option



SOLAS Specification Option

Precision Twin Tank Free Standing Fryers



422 Twin tank electric fryer (400mm wide)

OIL CAPACITY	NO. OF TANKS	NO. OF BASKETS	DIMENSIONS (mm)			NET WT
			H	W	D	
2 x 7.5-9 L	2	2	994	397.5	650	79



622 Twin tank electric fryer (600mm wide)

OIL CAPACITY	NO. OF TANKS	NO. OF BASKETS	DIMENSIONS (mm)			NET WT
			H	W	D	
2 x 12.5-14.5 L	2	2 (3,4)**	994	592	650	99

MODEL	PRICE £	PRICE €	POWER	OUTPUT /HR (kg)**	PHASE	SUPPLY CABLES
*PL422L32G0	£7252	€8339	2x7.5kW	2 x 18	3	2
*PL422L12G0	£7252	€8339	2x7.5kW	2 x 18	1	2
*PL422L31G0	£7252	€8339	2x7.5kW	2 x 18	3	1
*PL422M32G0	£7388	€8498	2 x 9kW	2 x 20	3	2
*PL422M12G0	£7388	€8498	2 x 9kW	2 x 20	1	2
*PL422M31G0	£7388	€8498	2 x 9kW	2 x 20	3	1
*PL422H32G0	£7536	€8667	2 x 11kW	2 x 22	3	2
*PL422H31G0	£7536	€8667	2 x 11kW	2 x 22	3	1

MODEL	PRICE £	PRICE €	POWER	OUTPUT /HR (kg)**	PHASE	SUPPLY CABLES
*PL622L32G0	£9246	€10,633	2x11.4kW	2x26.5	3	2
*PL622L31G0	£9246	€10,633	2x11.4kW	2x26.5	3	1
*PL622H32G0	£9419	€10,832	2 x 15kW	2x26.5	3	2
*PL622H31G0	£9419	€10,832	2 x 15kW	2x26.5	3	1

	PRICE £	PRICE €	DESCRIPTION
0*	£2422	€2786	Single oil return pump
0*	£4838	€5564	Twin oil return pump
0*	£1728	€1986	Single auto basket lift
0*	£3453	€3971	Twin auto basket lift
0*	£186	€213	Two rear castors (fixed)
0*	£370	€424	Four castors (fixed castors at rear)
0*	£476	€547	SOLAS option for twin tank free-standing

	PRICE £	PRICE €	DESCRIPTION
0*	£2422	€2786	Single oil return pump
0*	£4838	€5564	Twin oil return pump
0*	£1728	€1986	Single auto basket lift
0*	£3453	€3971	Twin auto basket lift
0*	£186	€213	Two rear castors (fixed)
0*	£370	€424	Four castors (fixed castors at rear)
0*	£476	€547	SOLAS option for twin tank free-standing

MODEL	PRICE £	PRICE €	DESCRIPTION
A FZ301093	£140	€161	Small baskets for 600mm wide twin tank

** 7mm Frozen Fries

*** No. of baskets shown in brackets are an available option. Please call for more details

0* Factory fitted option please request at point of ordering

† 412 pricing applies

* Please refer to pages F48 to F50 for electricity supply requirements



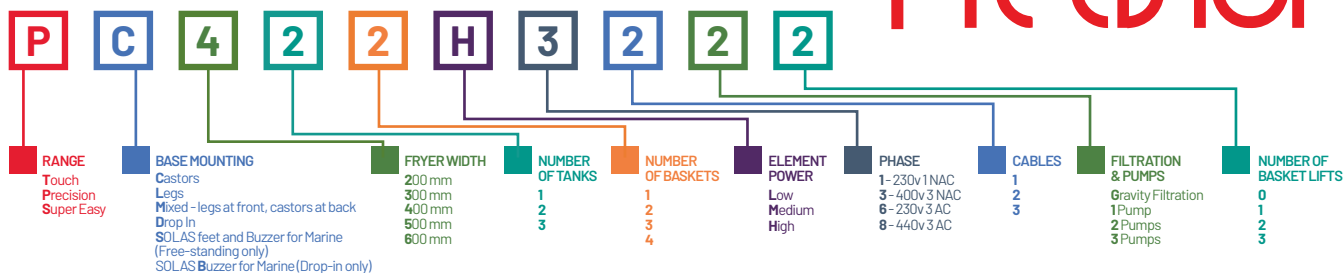

The models in the table are for base models supplied on legs, without pumped oil filtration or basket lifts.

Do you want an alternative configuration of baskets? **How many** supply cables would you like?
Do you require chargeable add on items such as castors and pumped oil filtration?

Please use our Fryer Designer to create your bespoke code. If you would like help to create code please **call us on 01522 875500**.

Precision Triple Tank Free Standing Fryers



633 Triple tank electric fryer (600mm wide)

OIL CAPACITY	NO. OF TANKS	NO. OF BASKETS	DIMENSIONS (mm)			NET WT
			H	W	D	
3x7.5-9 L	3	3	994	592	650	99

MODEL	PRICE £	PRICE €	POWER	OUTPUT /HR (kg)**	PHASE	SUPPLY CABLES
*PL633L31G0	£11,291	€12,986	3x7.5kW	3 x 18	3	1
*PL633L33G0	£11,291	€12,986	3x7.5kW	3 x 18	3	3
*PL633L13G0	£11,291	€12,986	3x7.5kW	3 x 18	1	3
*PL633M31G0	£11,379	€13,086	3x9kW	3 x 20	3	1
*PL633M33G0	£11,379	€13,086	3x9kW	3 x 20	3	3
*PL633M13G0	£11,379	€13,086	3 x 9kW	3 x 20	1	3
*PL633H33G0	£11,686	€13,440	3 x 11kW	3 x 22	3	3
*PL633H31G0	£11,686	€13,440	3 x 11kW	3 x 22	3	1

	PRICE £	PRICE €	DESCRIPTION
0*	£2422	€2786	Single oil return pump
0*	£7021	€8075	Triple oil return pump
0*	£1728	€1987	Single auto basket lift
0*	£3453	€3971	Twin auto basket lift
0*	£5065	€6170	Triple auto basket lift
0*	£186	€213	Two rear castors (fixed)
0*	£370	€424	Four castors (fixed castors at rear)
0*	£657	€756	SOLAS option for triple tank free-standing

** 7mm Frozen Fries

*** No. of baskets shown in brackets are an available option. Please call for more details

* Please refer to pages F48 to F50 for electricity supply requirements

0* Factory fitted option please request at point of ordering



Precision

As standard



Electronic Temperature Control



Touchpad Control



Timer



Temperature View



Adaptive Cooking



Gravity-fed Oil Filtration



Horizontally Coiled Elements



Allergen Control

Optional



xFri[®] Pumped Oil Filtration Option



LiftFri[®] Automatic Basket Lift Option



SOLAS Specification Option

Precision Single Tank Drop In Fryers



211 Single tank electric fryer (200mm wide)

OIL CAPACITY	NO. OF TANKS	NO. OF BASKETS	DIMENSIONS (mm)			NET WT
			H	W	D	
7.5-9 L	1	1	809	197.5	630	40

311 Single tank electric fryer (300mm wide)

OIL CAPACITY	NO. OF TANKS	NO. OF BASKETS	DIMENSIONS (mm)			NET WT
			H	W	D	
12.5-14.5 L	1	1 (2)***	809	297.5	630	47

MODEL	PRICE £	PRICE €	POWER	OUTPUT /HR (kg)**	PHASE	SUPPLY CABLES
*PD211L31G0	£4160	€4784	7.5kW	18	3	1
*PD211L11G0	£4160	€4784	7.5kW	18	1	1
*PD211M31G0	£4234	€4868	9kW	20	3	1
*PD211M11G0	£4234	€4868	9kW	20	1	1
*PD211H31G0	£4300	€4946	11kW	22	3	1

MODEL	PRICE £	PRICE €	POWER	OUTPUT /HR (kg)**	PHASE	SUPPLY CABLES
*PD311L31G0	£4962	€5707	11.4kW	28.5	3	1
*PD311H31G0	£5050	€5808	15kW	32	3	1

	PRICE £	PRICE €	DESCRIPTION
0*	£2422	€2786	Single oil return pump
0*	£1728	€1987	Single auto basket lift
0*	£293	€338	SOLAS option for single tank drop-in

	PRICE £	PRICE €	DESCRIPTION
0*	£2422	€2786	Single oil return pump
0*	£1728	€1987	Single auto basket lift
0*	£293	€338	SOLAS option for single tank drop-in

MODEL	PRICE £	PRICE €	DESCRIPTION
A FZ301093	£140	€161	Small baskets for 311



** 7mm Frozen Fries

*** No. of baskets shown in brackets are an available option. Please call for more details

0* Factory fitted option please request at point of ordering

* Please refer to pages F48 to F50 for electricity supply requirements

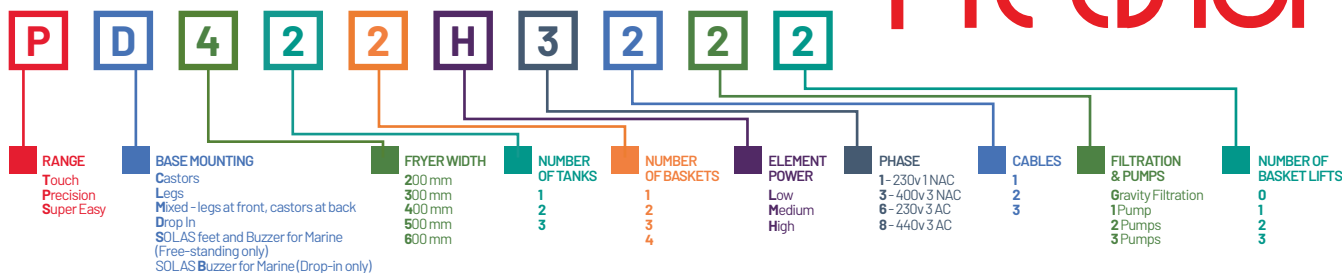

The models in the table are for base models supplied on legs, without pumped oil filtration or basket lifts.

Do you want an alternative configuration of baskets? **How many** supply cables would you like?
Do you require chargeable add on items such as castors and pumped oil filtration?

Please use our Fryer Designer to create your bespoke code. If you would like help to create code please **call us on 01522 875500**.

Precision Single Tank Drop In Fryers



411 Single tank electric fryer (400mm wide)						
OIL CAPACITY	NO. OF TANKS	NO. OF BASKETS	DIMENSIONS (mm)			NET WT
			H	W	D	
17-20.5 L	1	2 (1)**	809	397.5	630	62

MODEL	PRICE £	PRICE €	POWER	OUTPUT /HR (kg)**	PHASE	SUPPLY CABLES
*PD411L31G0	£5745	€6607	15kW	36	3	1
*PD411M31G0	£5884	€6767	18kW	40	3	1
*PD411H31G0	£6024	€6928	22kW	44	3	1



412 Single tank electric fryer (400mm wide)						
OIL CAPACITY	NO. OF TANKS	NO. OF BASKETS	DIMENSIONS (mm)			NET WT
			H	W	D	
17-20.5 L	1	2 (1)**	809	397.5	630	62

MODEL	PRICE £	PRICE €	POWER	OUTPUT /HR (kg)**	PHASE	SUPPLY CABLES
*PD412L31G0	£5745	€6607	15kW	36	3	1
*PD412M31G0	£5884	€6767	18kW	40	3	1
*PD412H31G0	£6024	€6928	22kW	44	3	1

	PRICE £	PRICE €	DESCRIPTION
O*	£2422	€2786	Single oil return pump
O*	£1728	€1987	Single auto basket lift
O*	£293	€338	SOLAS option for single tank drop-in

	MODEL	PRICE £	PRICE €	DESCRIPTION
A	FZ411048	£185	€214	Large basket for 411

	PRICE £	PRICE €	DESCRIPTION
O*	£2422	€2786	Single oil return pump
O*	£1728	€1987	Single auto basket lift
O*	£3453	€3971	Twin auto basket lift
O*	£293	€338	SOLAS option for single tank drop-in

	MODEL	PRICE £	PRICE €	DESCRIPTION
A	FZ411048	£178	€205	Large basket for 411

** 7mm Frozen Fries

*** No. of baskets shown in brackets are an available option. Please call for more details

* Please refer to pages F48 to F50 for electricity supply requirements

O* Factory fitted option please request at point of ordering



Precision

As standard



Electronic Temperature Control



Touchpad Control



Timer



Temperature View



Adaptive Cooking



Gravity-fed Oil Filtration



Horizontally Coiled Elements



Allergen Control

Optional



xFni[®] Pumped Oil Filtration Option



LiftFni[®] Automatic Basket Lift Option



SOLAS Specification Option

Precision Twin Tank Drop In Fryers



422 Twin tank electric fryer (400mm wide)						
OIL CAPACITY	NO. OF TANKS	NO. OF BASKETS	DIMENSIONS (mm)			NET WT
			H	W	D	
2 x 7.5-9 L	2	2	809	397.5	630	68



522 Twin tank electric fryer (500mm wide)						
OIL CAPACITY	NO. OF TANKS	NO. OF BASKETS	DIMENSIONS (mm)			NET WT
			H	W	D	
1 x 12.5-14.5 + 1 x 7.5-9 L	2	2 (3)***	809	495	630	87

MODEL	PRICE £	PRICE €	POWER	OUTPUT /HR (kg)**	PHASE	SUPPLY CABLES
*PD422L32G0	£7074	€8135	2 x 7.5kW	2 x 18	3	2
*PD422L12G0	£7074	€8135	2 x 7.5kW	2 x 18	1	2
*PD422L31G0	£7074	€8135	2 x 7.5kW	2 x 18	3	1
*PD422M32G0	£7213	€8296	2 x 9kW	2 x 20	3	2
*PD422M12G0	£7213	€8296	2 x 9kW	2 x 20	1	2
*PD422M31G0	£7213	€8296	2 x 9kW	2 x 20	3	1
*PD422H32G0	£7355	€8460	2 x 11kW	2 x 22	3	2
*PD422H31G0	£7355	€8460	2 x 11kW	2 x 22	3	1

MODEL	PRICE £	PRICE €	POWER	OUTPUT /HR (kg)**	PHASE	SUPPLY CABLES
*PD522L32G0	£7857	€9036	11.4+7.5kW	28.5 + 18	3	2
*PD522M32G0	£7919	€9108	11.4+9kW	28.5 + 20	3	2

	PRICE £	PRICE €	DESCRIPTION
O*	£2422	€2786	Single oil return pump
O*	£4838	€5564	Twin oil return pump
O*	£1728	€1987	Single auto basket lift
O*	£3453	€3971	Twin auto basket lift
O*	£476	€547	SOLAS option for twin tank drop-in

	PRICE £	PRICE €	DESCRIPTION
O*	£2422	€2786	Single oil return pump
O*	£4838	€5564	Twin oil return pump
O*	£1728	€1987	Single auto basket lift
O*	£3453	€3971	Twin auto basket lift
O*	£476	€547	SOLAS option for twin tank drop-in

MODEL	PRICE £	PRICE €	DESCRIPTION
A FZ301093	£140	€161	Small baskets for large tank

** 7mm Frozen Fries

*** No. of baskets shown in brackets are an available option. Please call for more details

O* Factory fitted option please request at point of ordering

* Please refer to pages F48 to F50 for electricity supply requirements



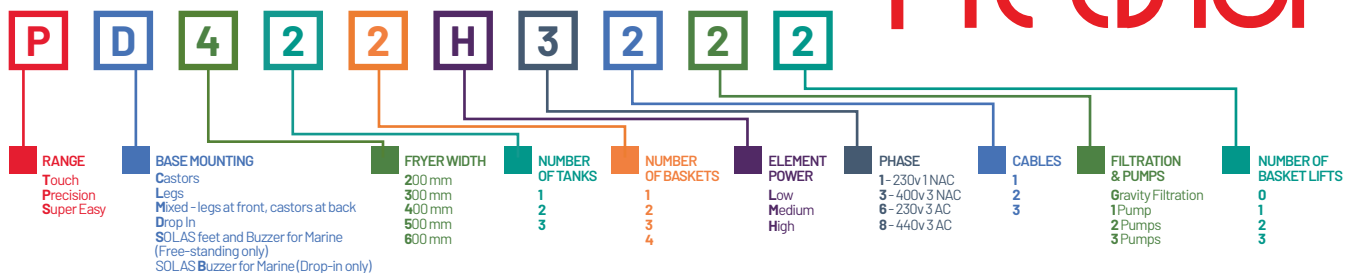

The models in the table are for base models supplied on legs, without pumped oil filtration or basket lifts.

Do you want an alternative configuration of baskets? **How many** supply cables would you like?
Do you require chargeable add on items such as castors and pumped oil filtration?

Please use our Fryer Designer to create your bespoke code. If you would like help to create code please **call us on 01522 875500**.

Precision Twin Tank Drop In Fryers



622 Twin tank electric fryer (600mm wide)						
OIL CAPACITY	NO. OF TANKS	NO. OF BASKETS	DIMENSIONS (mm)			NET WT
			H	W	D	
2x 12.5-14.5L	2	2 (3,4)***	809	592	630	94

MODEL	PRICE £	PRICE €	POWER	OUTPUT /HR (kg)**	PHASE	SUPPLY CABLES
*PD622L32G0	£8327	€9576	2x11.4kW	2x26.5	3	2
*PD622L31G0	£8327	€9576	2x11.4kW	2x26.5	3	1
*PD622H32G0	£8489	€9763	2x 15kW	2x26.5	3	2
*PD622H31G0	£8489	€9763	2x 15kW	2x26.5	3	1

	PRICE £	PRICE €	DESCRIPTION
O*	£2422	€2786	Single oil return pump
O*	£4838	€5564	Twin oil return pump
O*	£1728	€1987	Single auto basket lift
O*	£3453	€3971	Twin auto basket lift
O*	£476	€547	SOLAS option for twin tank drop-in

	MODEL	PRICE £	PRICE €	DESCRIPTION
A	FZ301093	£140	€161	Small baskets for 622

* Please refer to pages F48 to F50 for electricity supply requirements

** 7mm Frozen Fries
 *** No. of baskets shown in brackets are an available option. Please call for more details
 O* Factory fitted option please request at point of ordering



Precision

As standard



Electronic Temperature Control



Touchpad Control



Timer



Temperature View



Adaptive Cooking



Gravity-fed Oil Filtration



Horizontally Coiled Elements



Allergen Control

Optional



xFri[®] Pumped Oil Filtration Option



LiftFri[®] Automatic Basket Lift Option



SOLAS Specification Option

Precision Triple Tank Drop In Fryers



600mm wide triple tank fryer
EXCLUSIVE TO FRIFRI
 • Allergen Control
 • Flexibility

633 Triple tank electric fryer (600mm wide)

OIL CAPACITY	NO. OF TANKS	NO. OF BASKETS	DIMENSIONS (mm)			NET WT
			H	W	D	
3 x 7.5-9 L	3	3	809	592	630	94

MODEL	PRICE £	PRICE €	POWER	OUTPUT /HR (kg)**	PHASE	SUPPLY CABLES
*PD633L31G0	£9985	€11,484	3x7.5kW	3 x 18	3	1
*PD633L33G0	£9985	€11,484	3x7.5kW	3 x 18	3	3
*PD633L13G0	£9985	€11,484	3x7.5kW	3 x 18	1	3
*PD633M31G0	£10,194	€11,724	3 x 9kW	3 x 20	3	1
*PD633M33G0	£10,194	€11,724	3 x 9kW	3 x 20	3	3
*PD633M13G0	£10,194	€11,724	3 x 9kW	3 x 20	1	3
*PD633H33G0	£10,502	€12,077	3 x 11kW	3 x 22	3	3
*PD633H31G0	£10,502	€12,077	3 x 11kW	3 x 22	3	1

	PRICE £	PRICE €	DESCRIPTION
O*	£2422	€2786	Single oil return pump
O*	£7021	€8075	Triple oil return pump
O*	£1728	€1987	Single auto basket lift
O*	£3453	€3971	Twin auto basket lift
O*	£5365	€6170	Triple auto basket lift
O*	£657	€756	SOLAS option for triple tank drop-in

** 7mm Frozen Fries

*** No. of baskets shown in brackets are an available option. Please call for more details

O* Factory fitted option please request at point of ordering

* Please refer to pages F48 to F50 for electricity supply requirements

Super*easy

Outstanding value with no compromise in quality or performance.

When budget is a primary consideration, FriFri's unrivalled credentials, know-how and quality are still well within your reach.

Super Easy offers all the benefits you would expect from a FriFri fryer including high output from a small floor area and reliable, efficient performance that delivers consistently excellent fried food.

Quality construction, for example the 304 grade stainless steel pressed pan, and details such as the hinged frying elements will reassure you that Super Easy is anything but a compromise.

As standard



Thermostatic Temperature Control



Rotary Control Front



Allergen Control

Optional



Gravity-fed Oil Filtration



xFri[®] Pumped Oil Filtration Option

Ideally suited for use in



Restaurants



Hotels



Institutional Establishment



Super Easy 211



Super Easy 633



Super Easy 422 drop-in

Optional

If you're looking for that little bit extra in specification, options such as integral or pumped filtration and higher power are also available.



xFri[®] Pumped Oil Filtration Option

xFri[®] filters oil at the push of a button and returns the cleaned oil to the tank. You can filter the oil safely while its still hot, mid-service if necessary, and resume frying in under five minutes.



Allergen Control

For optimum oil segregation, fryers with two or three tanks can be supplied with separate oil pumps.



As standard



Thermostatic Temperature Control



Rotary Control Front



Allergen Control

Optional



Gravity-fed Oil Filtration



xFri[®] Pumped Oil Filtration Option

Super Easy Single Tank Free Standing Fryers



211 Single tank electric fryer (200mm wide)

OIL CAPACITY	NO. OF TANKS	NO. OF BASKETS	DIMENSIONS (mm)			NET WT
			H	W	D	
7.5-9 L	1	1	986	197.5	650	39

311 Single tank electric fryer (300mm wide)

OIL CAPACITY	NO. OF TANKS	NO. OF BASKETS	DIMENSIONS (mm)			NET WT
			H	W	D	
12.5-14.5 L	1	1 (2)***	986	297.5	650	48

With Gravity Filtration

MODEL	PRICE £	PRICE €	POWER	OUTPUT /HR (kg)**	PHASE	SUPPLY CABLES
*SL211L31G0	£2913	€3351	7.5kW	17	3	1
*SL211L11G0	£2913	€3351	7.5kW	17	1	1
*SL211H31G0	£2997	€3446	11kW	20	3	1

With Gravity Filtration

MODEL	PRICE £	PRICE €	POWER	OUTPUT /HR (kg)**	PHASE	SUPPLY CABLES
*SL311L31G0	£3616	€4160	11.4kW	26.5	3	1
*SL311H31G0	£3675	€4225	15kW	30	3	1

PRICE £	PRICE €	DESCRIPTION	
0*	£2422	€2786	Single oil return pump

PRICE £	PRICE €	DESCRIPTION	
0*	£2422	€2786	Single oil return pump
0*	£185	€212	Two rear castors (fixed)
0*	£370	€425	Four castors (fixed castors at rear)

MODEL	PRICE £	PRICE €	DESCRIPTION
A FZ301093	£140	€161	Small baskets for 300mm wide single tank

Without Gravity Filtration

MODEL	PRICE £	PRICE €	POWER	OUTPUT /HR (kg)**	PHASE	SUPPLY CABLES
*SL211L31N0	£2695	€3101	7.5kW	17	3	1
*SL211L11N0	£2695	€3101	7.5kW	17	1	1
*SL211H31N0	£2777	€3193	11kW	20	3	1

Without Gravity Filtration

MODEL	PRICE £	PRICE €	POWER	OUTPUT /HR (kg)**	PHASE	SUPPLY CABLES
*SL311L31N0	£3362	€3866	11.4kW	26.5	3	1
*SL311H31N0	£3423	€3936	15kW	30	3	1

** 7mm Frozen Fries

*** No. of baskets shown in brackets are an available option. Please call for more details

0* Factory fitted option please request at point of ordering

† 412 pricing applies

* Please refer to pages F48 to F50 for electricity supply requirements



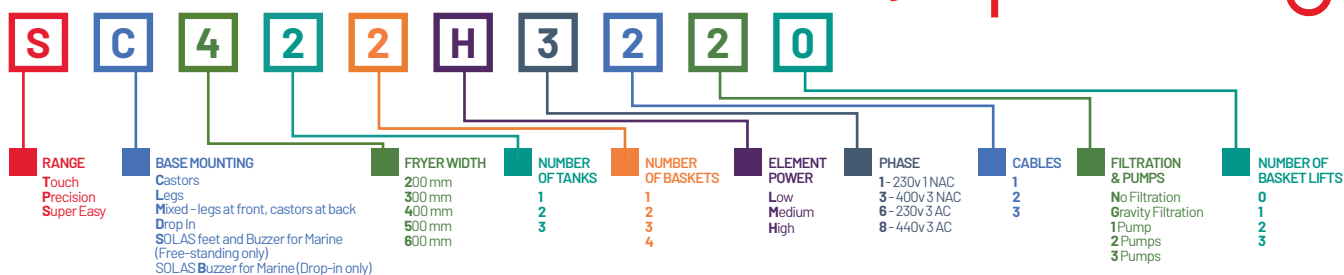

The models in the table are for base models supplied on legs, without pumped oil filtration or basket lifts.

Do you want an alternative configuration of baskets? **How many** supply cables would you like?
Do you require chargeable add on items such as castors and pumped oil filtration?

Please use our Fryer Designer to create your bespoke code. If you would like help to create code please **call us on 01522 875500**.

Super Easy Single Tank Free Standing Fryers



411 Single tank electric fryer (400mm wide)

OIL CAPACITY	NO. OF TANKS	NO. OF BASKETS	DIMENSIONS (mm)			NET WT
			H	W	D	
17-20.5 L	1	2 (1)***	986	397.5	650	52

412 Single tank electric fryer (400mm wide)

OIL CAPACITY	NO. OF TANKS	NO. OF BASKETS	DIMENSIONS (mm)			NET WT
			H	W	D	
17-20.5 L	1	2 (1)***	986	397.5	650	52

With Gravity Filtration						
MODEL	PRICE £	PRICE €	POWER	OUTPUT /HR (kg)**	PHASE	SUPPLY CABLES
*SL411L31G0	£3948	€4540	15kW	34	3	1
*SL411H31G0	£4191	€4820	22kW	40	3	1

With Gravity Filtration						
MODEL	PRICE £	PRICE €	POWER	OUTPUT /HR (kg)**	PHASE	SUPPLY CABLES
*SL412L31G0	£3948	€4540	15kW	34	3	1
*SL412H31G0	£4191	€4820	22kW	40	3	1

	PRICE £	PRICE €	DESCRIPTION
O*	£2422	€2786	Single oil return pump
O*	£186	€213	Two rear castors (fixed)
O*	£370	€425	Four castors (fixed castors at rear)

	PRICE £	PRICE €	DESCRIPTION
O*	£2422	€2786	Single oil return pump
O*	£186	€213	Two rear castors (fixed)
O*	£370	€425	Four castors (fixed castors at rear)

MODEL	PRICE £	PRICE €	DESCRIPTION
A FZ411048	£185	€214	Large basket for 400mm wide single tank

MODEL	PRICE £	PRICE €	DESCRIPTION
A FZ411048	£185	€214	Large basket for 400mm wide single tank

Without Gravity Filtration						
MODEL	PRICE £	PRICE €	POWER	OUTPUT /HR (kg)**	PHASE	SUPPLY CABLES
*SL411L31N0	£3692	€4249	15kW	34	3	1
*SL411H31N0	£3938	€4529	22kW	40	3	1

Without Gravity Filtration						
MODEL	PRICE £	PRICE €	POWER	OUTPUT /HR (kg)**	PHASE	SUPPLY CABLES
*SL412L31N0	£3692	€4249	15kW	34	3	1
*SL412H31N0	£3938	€4529	22kW	40	3	1

** 7mm Frozen Fries

*** No. of baskets shown in brackets are an available option. Please call for more details

O* Factory fitted option please request at point of ordering

* Please refer to pages F48 to F50 for electricity supply requirements



As standard



Thermostatic Temperature Control



Rotary Control Front



Allergen Control

Optional



Gravity-fed Oil Filtration



xFri[®] Pumped Oil Filtration Option

Super Easy Twin Tank Free Standing Fryers



422 Twin tank electric fryer (400mm wide)

OIL CAPACITY	NO. OF TANKS	NO. OF BASKETS	DIMENSIONS (mm)			NET WT
			H	W	D	
2 x 7.5-9 L	2	2	986	397.5	650	56



622 Twin tank electric fryer (600mm wide)

OIL CAPACITY	NO. OF TANKS	NO. OF BASKETS	DIMENSIONS (mm)			NET WT
			H	W	D	
2 x 12.5-14.5 L	2	2 (3,4)***	986	592	650	99

With Gravity Filtration

MODEL	PRICE £	PRICE €	POWER	OUTPUT /HR (kg)**	PHASE	SUPPLY CABLES
*SL422L32G0	£4936	€5677	2x7.5kW	2x17	3	2
*SL422L12G0	£4936	€5677	2x7.5kW	2x17	1	2
*SL422L31G0	£4936	€5677	2x7.5kW	2x17	3	1
*SL422H32G0	£5115	€5883	2 x 11kW	2x20	3	2
*SL422H31G0	£5115	€5883	2 x 11kW	2x20	3	1

With Gravity Filtration

MODEL	PRICE £	PRICE €	POWER	OUTPUT /HR (kg)**	PHASE	SUPPLY CABLES
*SL622L32G0	£5566	€6401	2 x 11.4kW	2x26.5	3	2
*SL622L31G0	£5566	€6401	2 x 11.4kW	2x26.5	3	1
*SL622H32G0	£5671	€6522	2 x 15kW	2x26.5	3	2
*SL622H31G0	£5671	€6522	2 x 15kW	2x26.5	3	1

	PRICE £	PRICE €	DESCRIPTION
0*	£2422	€2786	Single oil return pump
0*	£4838	€5564	Twin oil return pump
0*	£186	€213	Two rear castors (fixed)
0*	£370	€425	Four castors (fixed castors at rear)

	PRICE £	PRICE €	DESCRIPTION
0*	£2422	€2786	Single oil return pump
0*	£4838	€5564	Twin oil return pump
0*	£186	€213	Two rear castors (fixed)
0*	£370	€425	Four castors (fixed castors at rear)

	MODEL	PRICE £	PRICE €	DESCRIPTION
A	FZ301093	£140	€161	Small baskets for 600mm wide twin tank

Without Gravity Filtration

MODEL	PRICE £	PRICE €	POWER	OUTPUT /HR (kg)**	PHASE	SUPPLY CABLES
*SL422L32N0	£4504	€5180	2x7.5kW	2 x 17	3	2
*SL422L12N0	£4504	€5180	2x7.5kW	2 x 17	1	2
*SL422H32N0	£4546	€5228	2 x 11kW	2 x 20	3	2

Without Gravity Filtration

MODEL	PRICE £	PRICE €	POWER	OUTPUT /HR (kg)**	PHASE	SUPPLY CABLES
*SL622L32N0	£5146	€5919	2 x 11.4kW	2x26.5	3	2
*SL622H32N0	£5261	€6051	2 x 15kW	2x26.5	3	2

** 7mm Frozen Fries

*** No. of baskets shown in brackets are an available option. Please call for more details

0* Factory fitted option please request at point of ordering

† 412 pricing applies

* Please refer to pages F48 to F50 for electricity supply requirements



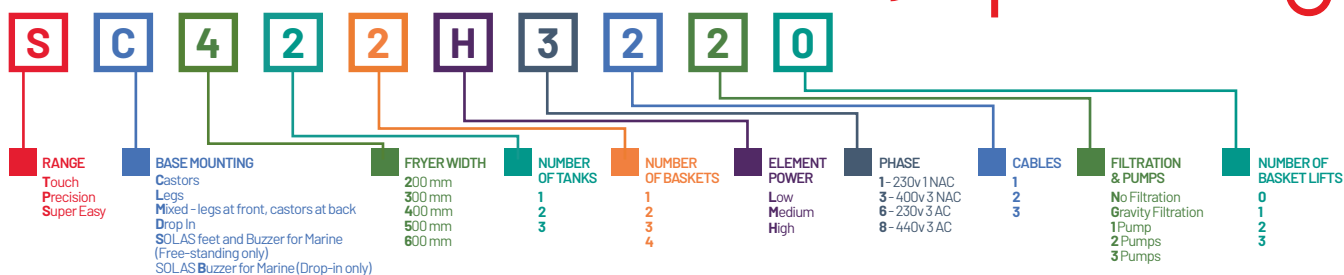

The models in the table are for base models supplied on legs, without pumped oil filtration or basket lifts.

Do you want an alternative configuration of baskets? **How many** supply cables would you like?
Do you require chargeable add on items such as castors and pumped oil filtration?

Please use our Fryer Designer to create your bespoke code. If you would like help to create code please **call us on 01522 875500**.

Super Easy Triple Tank Free Standing Fryers



633 Triple tank electric fryer (600mm wide)

OIL CAPACITY	NO. OF TANKS	NO. OF BASKETS	DIMENSIONS (mm)			NET WT
			H	W	D	
3 x 7.5-9 L	3	3	986	592	650	99

With Gravity Filtration

MODEL	PRICE £	PRICE €	POWER	OUTPUT /HR (kg)**	PHASE	SUPPLY CABLES
*SL633L31G0	£7596	€8736	3 x 7.5kW	3 x 18	3	1
*SL633L33G0	£7596	€8736	3 x 7.5kW	3 x 18	3	3
*SL633L13G0	£7683	€8835	3 x 7.5kW	3 x 18	1	3
*SL633H31G0	£7683	€8835	3 x 11kW	3 x 20	3	1
*SL633H33G0	£7683	€8835	3 x 11kW	3 x 20	3	3

	PRICE £	PRICE €	DESCRIPTION
0*	£2422	€2786	Single oil return pump
0*	£7021	€8075	Triple oil return pump
0*	£186	€213	Two rear castors (fixed)
0*	£370	€425	Four castors (fixed castors at rear)

Without Gravity Filtration

MODEL	PRICE £	PRICE €	POWER	OUTPUT /HR (kg)**	PHASE	SUPPLY CABLES
SL633L31N0	£7131	€8200	3 x 7.5kW	3 x 18	3	1
SL633L33N0	£7131	€8200	3 x 7.5kW	3 x 18	3	3
SL633L13N0	£7683	€8835	3 x 7.5kW	3 x 18	1	3
SL633H31N0	£7683	€8835	3 x 11kW	3 x 18	3	1
SL633H33N0	£7683	€8835	3 x 11kW	3 x 18	3	3

** 7mm Frozen Fries

*** No. of baskets shown in brackets are an available option. Please call for more details

* Please refer to pages F48 to F50 for electricity supply requirements

0* Factory fitted option please request at point of ordering

As standard



Thermostatic Temperature Control



Rotary Control Front



Allergen Control

Optional



Gravity-fed Oil Filtration



xFri[®] Pumped Oil Filtration Option

Super Easy Single Tank Drop In Fryers



211 Single tank electric fryer (200mm wide)

OIL CAPACITY	NO. OF TANKS	NO. OF BASKETS	DIMENSIONS (mm)			NET WT
			H	W	D	
7.5-9 L	1	1	864	197.5	630	21

With Gravity Filtration						
MODEL	PRICE £	PRICE €	POWER	OUTPUT /HR (kg)**	PHASE	SUPPLY CABLES
*SD211L31G0	£2529	€2908	7.5kW	17	3	1
*SD211L11G0	£2529	€2908	7.5kW	17	1	1
*SD211H31G0	£2715	€3122	11kW	20	3	1

PRICE £	PRICE €	DESCRIPTION
0*	£2422	€2786 Single oil return pump

Without Gravity Filtration						
MODEL	PRICE £	PRICE €	POWER	OUTPUT /HR (kg)**	PHASE	SUPPLY CABLES
*SD211L31N0	£2309	€2656	7.5kW	17	3	1
*SD211L11N0	£2309	€2656	7.5kW	17	1	1
*SD211H31N0	£2497	€2872	11kW	20	3	1



311 Single tank electric fryer (300mm wide)

OIL CAPACITY	NO. OF TANKS	NO. OF BASKETS	DIMENSIONS (mm)			NET WT
			H	W	D	
12.5-14.5 L	1	1 (2)***	864	297.5	630	26

With Gravity Filtration						
MODEL	PRICE £	PRICE €	POWER	OUTPUT /HR (kg)**	PHASE	SUPPLY CABLES
*SD311L31G0	£3260	€3749	11.4kW	26.5	3	1
*SD311H31G0	£3310	€3808	15kW	30	3	1

PRICE £	PRICE €	DESCRIPTION
0*	£2422	€2786 Single oil return pump

MODEL	PRICE £	PRICE €	DESCRIPTION
A FZ301093	£140	€161	Small baskets for 311

Without Gravity Filtration						
MODEL	PRICE £	PRICE €	POWER	OUTPUT /HR (kg)**	PHASE	SUPPLY CABLES
*SD311L31N0	£3006	€3457	11.4kW	26.5	3	1
*SD311H31N0	£3055	€3514	15kW	30	3	1

** 7mm Frozen Fries

*** No. of baskets shown in brackets are an available option. Please call for more details

0* Factory fitted option please request at point of ordering

* Please refer to pages F48 to F50 for electricity supply requirements

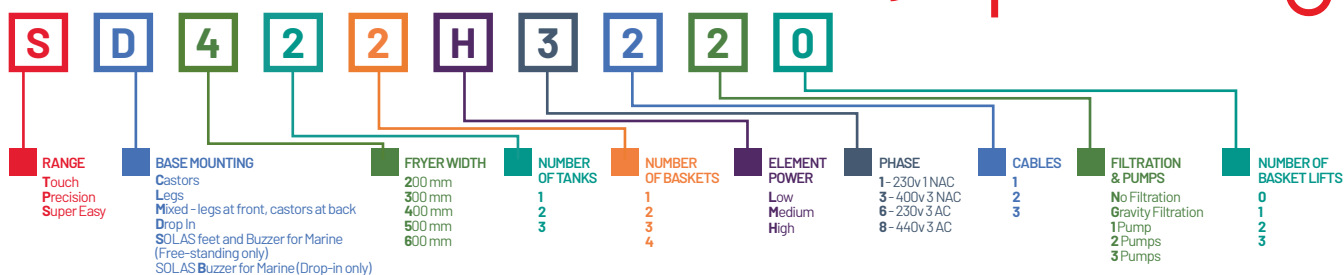

The models in the table are for base models supplied on legs, without pumped oil filtration or basket lifts.

Do you want an alternative configuration of baskets? **How many** supply cables would you like?
Do you require chargeable add on items such as castors and pumped oil filtration?

Please use our Fryer Designer to create your bespoke code. If you would like help to create code please **call us on 01522 875500**.

Super Easy Single Tank Drop In Fryers



411 Single tank electric fryer (400mm wide)

OIL CAPACITY	NO. OF TANKS	NO. OF BASKETS	DIMENSIONS (mm)			NET WT
			H	W	D	
17-20.5 L	1	2 (1)**	864	397.5	630	30

412 Single tank electric fryer (400mm wide)

OIL CAPACITY	NO. OF TANKS	NO. OF BASKETS	DIMENSIONS (mm)			NET WT
			H	W	D	
17-20.5 L	1	2 (1)**	864	397.5	630	30

With Gravity Filtration						
MODEL	PRICE £	PRICE €	POWER	OUTPUT /HR (kg)**	PHASE	SUPPLY CABLES
*SD411L31G0	£3453	€3971	15kW	34	3	1
*SD411H31G0	£3668	€4219	22kW	40	3	1

With Gravity Filtration						
MODEL	PRICE £	PRICE €	POWER	OUTPUT /HR (kg)**	PHASE	SUPPLY CABLES
*SD412L31G0	£3453	€3971	15kW	34	3	1
*SD412H31G0	£3668	€4217	22kW	40	3	1

PRICE £	PRICE €	DESCRIPTION	
0*	£2422	€2786	Single oil return pump

PRICE £	PRICE €	DESCRIPTION	
0*	£2422	€2786	Single oil return pump

MODEL	PRICE £	PRICE €	DESCRIPTION
A FZ411048	£185	€214	Large basket for 411

MODEL	PRICE £	PRICE €	DESCRIPTION
A FZ411048	£185	€214	Large basket for 411

Without Gravity Filtration						
MODEL	PRICE £	PRICE €	POWER	OUTPUT /HR (kg)**	PHASE	SUPPLY CABLES
*SD412L31N0	£3201	€3680	15kW	34	3	1
*SD412H31N0	£3413	€3926	22kW	40	3	1

Without Gravity Filtration						
MODEL	PRICE £	PRICE €	POWER	OUTPUT /HR (kg)**	PHASE	SUPPLY CABLES
*SD412L31N0	£3201	€3680	15kW	34	3	1
*SD412H31N0	£3413	€3926	22kW	40	3	1

** 7mm Frozen Fries

*** No. of baskets shown in brackets are an available option. Please call for more details

* Please refer to pages F48 to F50 for electricity supply requirements

0* Factory fitted option please request at point of ordering





As standard



Thermostatic Temperature Control



Rotary Control Front



Allergen Control

Optional



Gravity-fed Oil Filtration



xFlt[®] Pumped Oil Filtration Option

Super Easy Twin Tank Drop In Fryers



422 Twin tank electric fryer (400mm wide)

OIL CAPACITY	NO. OF TANKS	NO. OF BASKETS	DIMENSIONS (mm)			NET WT
			H	W	D	
2 x 7.5-9 L	2	2	864	397.5	630	35

With Gravity Filtration

MODEL	PRICE £	PRICE €	POWER	OUTPUT /HR (kg)**	PHASE	SUPPLY CABLES
*SD422L32G0	£4438	€5104	2x7.5kW	2x17	3	1
*SD422L12G0	£4438	€5104	2x7.5kW	2x17	1	2
*SD422L31G0	£4438	€5104	2x7.5kW	2x17	3	1
*SD422H32G0	£4691	€5395	2 x 11kW	2x20	3	2
*SD422H31G0	£4691	€5395	2 x 11kW	2x20	3	1

	PRICE £	PRICE €	DESCRIPTION
0*	£2422	€2786	Single oil return pump
0*	£4838	€5564	Twin oil return pump

Without Gravity Filtration

MODEL	PRICE £	PRICE €	POWER	OUTPUT /HR (kg)**	PHASE	SUPPLY CABLES
*SD422L32N0	£4004	€4605	2x7.5kW	2x17	3	1
*SD422L12N0	£4004	€4605	2x7.5kW	2x17	1	2
*SD422H32N0	£4206	€4898	2 x 11kW	2x20	3	2

** 7mm Frozen Fries

*** No. of baskets shown in brackets are an available option. Please call for more details

0* Factory fitted option please request at point of ordering

* Please refer to pages F48 to F50 for electricity supply requirements



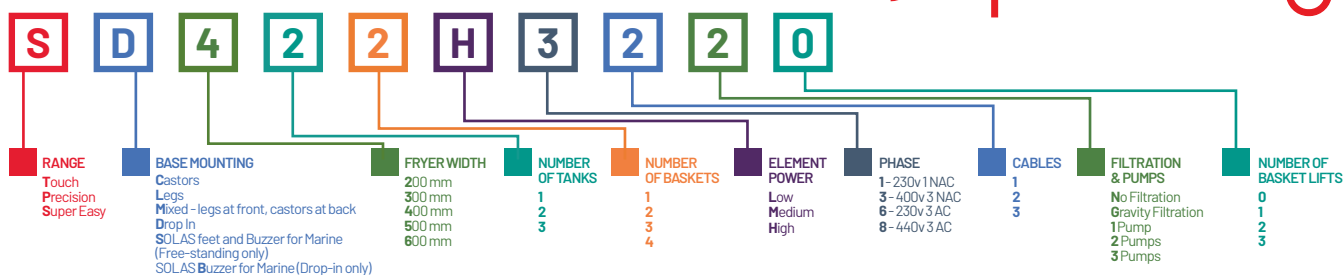

The models in the table are for base models supplied on legs, without pumped oil filtration or basket lifts.

Do you want an alternative configuration of baskets? **How many** supply cables would you like?
Do you require chargeable add on items such as castors and pumped oil filtration?

Please use our Fryer Designer to create your bespoke code. If you would like help to create code please **call us on 01522 875500**.

Super Easy Twin Tank Drop In Fryers



622 Twin tank electric fryer (600mm wide)

OIL CAPACITY	NO. OF TANKS	NO. OF BASKETS	DIMENSIONS (mm)			NET WT
			H	W	D	
2x 12.5-14.5L	2	2 (3,4)***	864	592	630	76

With Gravity Filtration

MODEL	PRICE £	PRICE €	POWER	OUTPUT /HR (kg)**	PHASE	SUPPLY CABLES
*SD622L32G0	£4955	€5699	2 x 11.4kW	2 x 26.5	3	2
*SD622L31G0	£4955	€5698	2 x 11.4kW	2 x 26.5	3	1
*SD622H32G0	£5105	€5872	2 x 15kW	2 x 30	3	2
*SD622H31G0	£5105	€5872	2 x 15kW	2 x 30	3	1

	PRICE £	PRICE €	DESCRIPTION
O*	£2422	€2786	Single oil return pump
O*	£4838	€5564	Twin oil return pump

MODEL	PRICE £	PRICE €	DESCRIPTION
A FZ301093	£140	€161	Small baskets for 622

Without Gravity Filtration

MODEL	PRICE £	PRICE €	POWER	OUTPUT /HR (kg)**	PHASE	SUPPLY CABLES
*SD622L32N0	£4581	€5269	2x 11.4kW	2 x 26.5	3	2
*SD622H32N0	£4734	€5444	2 x 15kW	2 x 26.5	3	2

** 7mm Frozen Fries

*** No. of baskets shown in brackets are an available option. Please call for more details

* Please refer to pages F48 to F50 for electricity supply requirements

O* Factory fitted option please request at point of ordering

As standard



Thermostatic Temperature Control



Rotary Control Front



Allergen Control

Optional



Gravity-fed Oil Filtration



xFri® Pumped Oil Filtration Option

Super Easy Triple Tank Drop In Fryers



600mm wide triple tank fryer
EXCLUSIVE TO FRIFRI
 • Allergen Control
 • Flexibility

633 Triple tank electric fryer (600mm wide)

OIL CAPACITY	NO. OF TANKS	NO. OF BASKETS	DIMENSIONS (mm)			NET WT
			H	W	D	
3 x 7.5-9 L	3	3	864	592	630	76

With Gravity Filtration

MODEL	PRICE £	PRICE €	POWER	OUTPUT /HR (kg)**	PHASE	SUPPLY CABLES
*SD633L31G0	£6348	€7301	3 x 7.5kW	3 x 18	3	1
*SD633L33G0	£6348	€7301	3 x 7.5kW	3 x 18	3	3
*SD633L13G0	£6348	€7301	3 x 7.5kW	3 x 18	1	3
*SD633H31G0	£6668	€7669	3 x 11kW	3 x 20	3	1
*SD633H33G0	£6668	€7669	3 x 11kW	3 x 20	3	3

	PRICE £	PRICE €	DESCRIPTION
0*	£2422	€2786	Single oil return pump
0*	£7021	€8075	Triple oil return pump

Without Gravity Filtration

MODEL	PRICE £	PRICE €	POWER	OUTPUT /HR (kg)**	PHASE	SUPPLY CABLES
*SD633L31N0	£5697	€6552	3 x 7.5kW	3 x 18	3	1
*SD633L33N0	£5697	€6552	3 x 7.5kW	3 x 18	3	3
*SD633L13N0	£5697	€6552	3 x 7.5kW	3 x 18	1	3
*SD633H31N0	£6020	€6922	3 x 11kW	3 x 20	3	1
*SD633H33N0	£6020	€6922	3 x 11kW	3 x 20	3	3

** 7mm Frozen Fries

*** No. of baskets shown in brackets are an available option. Please call for more details

0* Factory fitted option please request at point of ordering

* Please refer to pages F48 to F50 for electricity supply requirements

Add-on Items

Accessories, consumables, spares and options



SOLAS specification feature modified feet for secure fastening to the floor



Castors available on all freestanding fryers, except, for safety reasons, 211 models

SOLAS-Compliant Fryers

The Touch, Precision, and Super Easy fryer models are available in SOLAS (Safety of Life at Sea) specifications, ensuring safe and dependable performance in marine environments. Designed specifically for marine use, these fryers feature an audible alarm that activates if the high-temperature cut-out fails. Free-standing models come with flanged feet, providing secure fastening to the deck for optimal stability during operation.

Jointing Strips

Upgrade your kitchen configuration with stainless steel jointing strips, expertly designed to connect two or more fryers side by side. This reduces oil ingress between units, maintaining a cleaner and more efficient workspace.

Fryer Basket Options

Choose from our versatile range of fryer baskets to suit your specific needs. Opt for smaller baskets to cook precise, made-to-order portions or larger baskets for high-volume cooking, allowing you to optimize efficiency and reduce waste.

Tailored Solutions for Your Operation

To discuss the wide range of options and accessories available to support your operation, **please contact our team on UK 01522 875500 or Export +44 1522 503250**. We're here to help you create the ideal solution for your needs.



Profi+

As standard



Electronic Temperature Control



Rotary Control Front

Professional performance from a compact, sturdy counter top fryer.



Limited space needn't limit your frying capability. Profi+ is a truly professional fryer. Profi+ offers the same output and features as the Basic+ range. Precise electronic temperature control, for example, maintains oil temperature to within +/-1°C of the selected setting.

The control panel is front-mounted – much safer than having to reach over the fryer. Other features include a lid that cleverly slots in at the rear of the fryer. This provides safer storage as well as a convenient splashback and basket support. A front drain valve facilitates safe, easy drainage of used oil.

Ideally suited for use in

- Fine cuisine – Superb temperature control for consistently excellent results
- Restaurants – Consistently produce crisp, succulent, great tasting fried food

Benefits at a glance

- Counter top
- Powerful
- Highly responsive electronic control
- Enhanced operator safety
- Safe and easy to use front draining valve
- Durable



Profi+ 6



Profi+ 10



Profi+ 8+8



- A powerful counter top fryer capable of producing up to 25 kg of chips per hour
- Highly responsive digital electronic control able to maintain oil to +/-1 °C of the temperature selected
- Enhanced operator safety with front mounted control panel
- Rear-mounted slot-in lid that also acts as a splashback and basket support
- Safe and easy to use front valve for draining off used oil
- One piece pressed stainless steel tank with rounded corners for increased durability and reduced cleaning times

Profi+ Single Tank Counter Top Electric Fryers



Profi + 6 Single Tank Counter Top Fryer									Profi + 8 Single Tank Counter Top Fryer									Profi + 10 Single Tank Counter Top Fryer																	
MODEL	PRICE £	PRICE €	POWER	OUTPUT /HR (kg)**	OIL CAP	NO. OF BASKETS	DIMENSIONS (mm)				WT	MODEL	PRICE £	PRICE €	POWER	OUTPUT /HR (kg)**	OIL CAP	NO. OF BASKETS	DIMENSIONS (mm)				WT	MODEL	PRICE £	PRICE €	POWER	OUTPUT /HR (kg)**	OIL CAP	NO. OF BASKETS	DIMENSIONS (mm)				WT
							H	W	D									H	W	D								H	W	D					
*650946	£1765	€2031	4.6kW	14	5-7 L	1	455	270	475	15	*650947	£1933	€2223	6.9kW	22	8-9.5L	1	455	360	475	16	*651068	£2587	€2975	6.9kW	20	12-15L	2	455	540	475	23			
											*650957	£1933	€2223	6.9kW	22	8-9.5L	2	455	360	475	17														
																						*650948	£2587	€2975	9.2kW	25	12-15L	2	455	540	475	23			

Profi+ Twin Tank Counter Top Electric Fryers

- A powerful counter top fryer capable of producing 44 kg of chips per hour
- Highly responsive digital electronic control able to maintain oil to +/-1 °C of the temperature selected
- Enhanced operator safety with front mounted control panel
- Rear-mounted slot-in lid that also acts as a splashback and basket support
- Safe and easy to use front valve for draining off used oil
- One piece pressed stainless steel tank with rounded corners for increased durability and reduced cleaning times



Profi + 6 + 6 Twin Tank Counter Top Fryer											
MODEL	PRICE £	PRICE €	POWER	OUTPUT /HR (kg)**	OIL CAP	NO. OF BASKETS	DIMENSIONS (mm)				WT
							H	W	D		
*650950	£3392	€3901	2x4.6kW	2 x 14	2 x 5-7 L	2	455	540	475	25	

Profi + 8 + 8 Twin Tank Counter Top Fryer											
MODEL	PRICE £	PRICE €	POWER	OUTPUT /HR (kg)**	OIL CAP	NO. OF BASKETS	DIMENSIONS (mm)				WT
							H	W	D		
*650952	£3620	€4164	2x6.9kW	2 x 22	2x8-9.5L	2	455	720	475	30	
*650963	£3620	€4164	2x6.9kW	2 x 22	2x8-9.5L	4	455	720	475	30	

** 7mm Frozen Fries

All Profi+ models are three phase, 400 volt, however we can customise the voltage to suit your requirements. Please call for alternative voltages.

* Please refer to pages F48 to F50 for electricity supply requirements



frita+ & eco

As standard (Frita+)



Electronic Temperature Control



Rotary Control Front

As standard (Eco)



Electronic Temperature Control



Rotary Control Rear

Affordable, durable and efficient – they won't let you down



Frita+ fryers share many of the design details of the Profi+ range. These include a safe, easy-to-use front valve for draining off used oil and the rear-mounted slot-in lid that also acts as a splashback and basket support. Operator safety is further enhanced by the front-mounted control panel.

All Eco and Frita+ models incorporate a mechanical thermostat for maintaining oil to within +/-8°C of the temperature selected.

Ideally suited for use in

- Cafes – effortlessly produce fries to support your menu offering
- Pubs – ideal for cooking highly flavoured menu items
- Restaurants – cater for special dietary needs with this standalone fryer

Benefits at a glance

- Durable
- Efficient
- Well designed fryers
- Mechanical thermostat



Frita+ 6



Eco 6+6

- A durable, efficient and well designed fryer that won't let you down
- Mechanical thermostat for maintaining oil temperature to within +/-8 °C of the temperature set
- Enhanced operator safety with front mounted control panel
- Rear-mounted slot-in lid that also acts as a splashback and basket support
- Safe and easy to use front valve for draining off used oil
- One piece pressed stainless steel tank with rounded corners for increased durability and reduced cleaning times

Frita+ Single Tank Counter Top Electric Fryers



Frita + 6 Single Tank Counter Top Fryer										
MODEL	PRICE £	PRICE €	POWER	OUTPUT /HR (kg)**	OIL CAP	NO. OF BASKETS	DIMENSIONS (mm)			WT
							H	W	D	
*652000	£1203	€1384	4.6kW	10.5	5-7L	1	455	270	475	14

Frita + 8 Single Tank Counter Top Fryer										
MODEL	PRICE £	PRICE €	POWER	OUTPUT /HR (kg)**	OIL CAP	NO. OF BASKETS	DIMENSIONS (mm)			WT
							H	W	D	
*652001	£1382	€1590	6.9kW	16.5	8-9.5L	2	455	360	475	16
*652004	£1382	€1590	6.9kW	16.5	8-9.5L	1	455	360	475	16

All Frita+ models are three phase, 400 volt, however we can customise the voltage to suit your requirements. Please call for alternative voltages.

Eco Single Tank Counter Top Electric Fryers

- Ideal for the supply of portions of chips, as an occasional fryer or for cooking highly flavoured food
- Mechanical thermostat for maintaining oil temperature to within +/-8 °C of the temperature set
- One piece pressed stainless steel tank with rounded corners and lift-out control panel for reduced cleaning times



Eco 4 Single Tank Counter Top Fryer										
MODEL	PRICE £	PRICE €	POWER	OUTPUT /HR (kg)**	OIL CAP	NO. OF BASKETS	DIMENSIONS (mm)			WT
							H	W	D	
*650102	£419	€482	2.3kW	5.4	3-4L	1	295	203	375	5
*650101	†£424	€488	3.2kW	6	3-4L	1	295	203	375	5

Eco 6 Single Tank Counter Top Fryer										
MODEL	PRICE £	PRICE €	POWER	OUTPUT /HR (kg)**	OIL CAP	NO. OF BASKETS	DIMENSIONS (mm)			WT
							H	W	D	
*650105	†£487	€560	3.2kW	7	4-5L	1	295	254	375	6

Eco Twin Tank Counter Top Electric Fryers

- Ideal for the supply of portions of chips, as an occasional fryer or for cooking highly flavoured food
- Mechanical thermostat for maintaining oil temperature to within +/-8 °C of the temperature set
- One piece pressed stainless steel tank with rounded corners and lift-out control panel for reduced cleaning times



Eco 4 + 4 Twin Tank Counter Top Fryer										
MODEL	PRICE £	PRICE €	POWER	OUTPUT /HR (kg)**	OIL CAP	NO. OF BASKETS	DIMENSIONS (mm)			WT
							H	W	D	
*650104	£804	€924	2x2.3kW	2 x 5.4	2 x 3-4 L	2	295	384	375	10
*650104/UK	£804	€924	2x2.3kW	2 x 5.4	2 x 3-4 L	2	295	384	375	10
*650103	†£809	€931	2x3.2kW	2 x 6	3 x 3-4 L	2	295	384	375	10

Eco 6 + 6 Twin Tank Counter Top Fryer										
MODEL	PRICE £	PRICE €	POWER	OUTPUT /HR (kg)**	OIL CAP	NO. OF BASKETS	DIMENSIONS (mm)			WT
							H	W	D	
*650106	†£938	€1079	2x3.2kW	2 x 7	2 x 4-5L	2	295	486	375	11

** 7mm Frozen Fries

All Eco models are single phase, 230 volt. † Not available in the UK.

* Please refer to pages F48 to F50 for electricity supply requirements

Silofrit

Crisp, succulent, piping hot fries every time.



Silofrit chip scuttles ensure fries remain hot and crispy for longer – a real bonus during busy periods.

Silofrit offers counter top, free standing and built in models, all manufactured in durable 304 grade stainless steel. Fries are kept piping hot and crispy by the infra-red lamp above and by a drain plate and element* located beneath.

For added convenience the removable gastronorm/container and drain plate can be cleaned in the dishwasher.

*Excludes built-in model

Ideally suited for use in

- Quick Service Restaurant – providing a continuous supply of hot and crispy fries during busy periods
- Restaurants – great tasting, crisp, succulent, piping hot fries on demand

Benefits at a glance

- Free standing, counter top and built in models available
- Crisp, delicious, piping hot fries every time
- Removable gastronorm and drain plate can be cleaned in the dishwasher
- Manufactured in durable 304 grade stainless steel

Silofrit Chip Scuttles



Silofrit Free Standing Chip Scuttle

MODEL	PRICE £	PRICE €	POWER	DIMENSIONS (mm)			WT
				H	W	D	
601210	£3236	€3721	1kW	1155	400	620	46

Silofrit Counter Top Chip Scuttle

MODEL	PRICE £	PRICE €	POWER	DIMENSIONS (mm)			WT
				H	W	D	
650722	£1960	€2254	1kW	540	400	620	21

Silofrit Built In Chip Scuttle

MODEL	PRICE £	PRICE €	POWER	DIMENSIONS (mm)			WT
				H	W	D	
651105	£1929	€2219	0.65kW	455	400	630	12

Super*easy pasta

As standard



Thermostatic Temperature Control



Rotary Control Front

Optional



SOLAS Specification Option

Designed and built to ensure longer life in the harshest of conditions.



Experienced chefs and independent kitchens really appreciate the quality, performance and outstanding value of the Super Easy 311 pasta cooker.

With built in and free standing models available, the tank pressed from a single piece of superior grade 316 stainless steel and incoloy heating element provide superior resistance to punishing salt and starch corrosion at high temperatures.

Pasta cookers listed are 3 phase, 400 volt, however we can customise the voltage to suit your requirements.

High outputs of pasta enable you to keep pace with demand, even during peak periods

Ideally suited for use in

- Quick Service Restaurants – smaller baskets enable smaller portions to be cooked in constant rotation
- Restaurants – serve perfect pasta each and every time

Benefits at a glance

- Free standing and built in models available
- Designed and built to ensure longer life in the harshest of conditions
- Enables you to cook all types of pasta reliably and consistently with great results

- High outputs of pasta enable you to keep pace with demand, even during peak periods
- Optional smaller baskets enable smaller portions to be cooked in constant rotation maximising output and efficiency
- Plumbed to fresh water supply and waste for quick, easy filling and drainage of tank
- Starch removal keeps water fresh for longer to ensure perfect results
- Two tilt position elements to aid draining and cleaning

Super Easy Pasta Cookers



Super Easy Pasta 311 Free Standing Pasta Cooker								
MODEL	PRICE £	PRICE €	POWER	OUTPUT /HR (kg)**	DIMENSIONS (mm)			WT
					H	W	D	
*680131/A500	£4144	€4766	7.5kW	14	990	300	650	70

** Fresh Penne Pasta

Super Easy Pasta 311 Built In Pasta Cooker								
MODEL	PRICE £	PRICE €	POWER	OUTPUT /HR (kg)**	DIMENSIONS (mm)			WT
					H	W	D	
*690132/A700	£4069	€4680	7.5kW	14	875	300	630	42

** Fresh Penne Pasta

MODEL	PRICE £	PRICE €	DESCRIPTION
A DVC015ZR10	£163	€188	Single portion pasta basket
A DVC014ZR10	£290	€334	Basket for 311 pasta cookers
A FB2	£1016	€1168	Basket with 6 single portion baskets for 311 pasta cookers

* Please refer to pages F48 to F50 for electricity supply requirements



Electricity Supply Requirements

Electrical products not listed on this page are supplied for operation on a 230/240v, 13 amp supply.

Brand	Product Code	Power Supply/ Connection Type	Electrical Supply Rating [watts]	Single Phase		Three Phase			
				Amps	Voltage	Amps - Phase 1	Amps - Phase 2	Amps - Phase 3	Voltage
FriFri	650101	1-phase	3,200	13.9	230				N/A
FriFri	650103	1-phase	2 x 3,200	2 x 13.9	230				N/A
FriFri	650105	1-phase	3,200	13.9	230				N/A
FriFri	650106	1-phase	2 x 3,200	2 x 13.9	230				N/A
FriFri	650946	3-phase	4,600		N/A	6.7	6.7	6.7	400
FriFri	650947	3-phase	6,900		N/A	10.0	10.0	10.0	400
FriFri	650948	3-phase	9,200		N/A	13.3	13.3	13.3	400
FriFri	650950	3-phase	2 x 4,600		N/A	2 x 6.7	2 x 6.7	2 x 6.7	400
FriFri	650952	3-phase	2 x 6,900		N/A	2 x 10.0	2 x 10.0	2 x 10.0	400
FriFri	650957	3-phase	6,900		N/A	10.0	10.0	10.0	400
FriFri	650963	3-phase	2 x 6,900		N/A	2 x 10.0	2 x 10.0	2 x 10.0	400
FriFri	651068	3-phase	6,900		N/A	10.0	10.0	10.0	400
FriFri	652000	3-phase	4,600		N/A	6.7	6.7	6.7	400
FriFri	652001	3-phase	6,900		N/A	10.0	10.0	10.0	400
FriFri	652004	3-phase	6,900		N/A	10.0	10.0	10.0	400
FriFri	680131/A500	3-phase	7,500		N/A	10.9	10.9	10.9	400
FriFri	690132/A700	3-phase	7,500		N/A	10.9	10.9	10.9	400
FriFri	PD211H31G0	3-phase	11,000		N/A	15.9	15.9	15.9	400
FriFri	PD211L11G0	1-phase	7,500	32.6	230				N/A
FriFri	PD211L31G0	3-phase	7,500		N/A	10.9	10.9	10.9	400
FriFri	PD211M11G0	1-phase	9,000	39.1	230				N/A
FriFri	PD211M31G0	3-phase	9,000		N/A	13.0	13.0	13.0	400
FriFri	PD311H31G0	3-phase	15,000		N/A	21.7	21.7	21.7	400
FriFri	PD411L31G0	3-phase	15,000		N/A	26.1	26.1	26.1	400
FriFri	PD411M31G0	3-phase	18,000		N/A	21.7	21.7	21.7	400
FriFri	PD411H31G0	3-phase	22,000		N/A	31.9	31.9	31.9	400
FriFri	PD311L31G0	3-phase	11,400		N/A	16.5	16.5	16.5	400
FriFri	PD412H31G0	3-phase	22,000		N/A	31.9	31.9	31.9	400
FriFri	PD412L31G0	3-phase	15,000		N/A	21.7	21.7	21.7	400
FriFri	PD412M31G0	3-phase	18,000		N/A	26.1	26.1	26.1	400
FriFri	PD422H32G0	3-phase	2 x 11,000		N/A	2 x 15.9	2 x 15.9	2 x 15.9	400
FriFri	PD422H31G0	3-phase	22,000		N/A	31.9	31.9	31.9	400
FriFri	PD422L12G0	1-phase	2 x 7,500	2 x 32.6	230				N/A
FriFri	PD422L31G0	3-phase	15,000		N/A	21.7	21.7	21.7	400
FriFri	PD422L32G0	3-phase	2 x 7,500		N/A	2 x 10.9	2 x 10.9	2 x 10.9	400
FriFri	PD422M12G0	1-phase	2 x 9,000	2 x 39.1	230				N/A
FriFri	PD422M31G0	3-phase	18,000		N/A	26.1	26.1	26.1	400
FriFri	PD422M32G0	3-phase	2 x 9,000		N/A	2 x 13.0	2 x 13.0	2 x 13.0	400
FriFri	PD522L32G0	3-phase	11,400; 7,500		N/A	16.5 + 10.9	16.5 + 10.9	16.5 + 10.9	400
FriFri	PD522M32G0	3-phase	11,400; 9,000		N/A	16.5 + 13.0	16.5 + 13.0	16.5 + 13.0	400
FriFri	PD622H32G0	3-phase	2 x 15,000		N/A	2 x 21.7	2 x 21.7	2 x 21.7	400
FriFri	PD622H31G0	3-phase	30,000		N/A	43.4	43.4	43.4	400
FriFri	PD622L32G0	3-phase	2 x 11,400		N/A	2 x 16.5	2 x 16.5	2 x 16.5	400
FriFri	PD622L31G0	3-phase	22,800		N/A	33	33	33	400
FriFri	PD633L13G0	1-phase	3 x 7,500	3 x 32.6	230				N/A
FriFri	PD633L31G0	3-phase	22,500		N/A	32.6	32.6	32.6	400
FriFri	PD633L33G0	3-phase	3 x 7,500		N/A	3 x 10.9	3 x 10.9	3 x 10.9	400
FriFri	PD633M13G0	1-phase	3 x 9,000	3 x 39.1	230				N/A
FriFri	PD633M31G0	3-phase	27,000		N/A	39.1	39.1	39.1	400
FriFri	PD633H33G0	3-phase	30,000		N/A	43.4	43.4	43.4	400
FriFri	PD633H31G0	3-phase	30,000		N/A	43.4	43.4	43.4	400
FriFri	PD633M33G0	3-phase	3 x 9,000		N/A	3 x 13.0	3 x 13.0	3 x 13.0	400
FriFri	PL211H31G0	3-phase	11,000		N/A	15.9	15.9	15.9	400
FriFri	PL211L11G0	1-phase	7,500	32.6	230				N/A
FriFri	PL211L31G0	3-phase	7,500		N/A	10.9	10.9	10.9	400
FriFri	PL211M11G0	1-phase	9,000	39.1	230				N/A
FriFri	PL211M31G0	3-phase	9,000		N/A	13.0	13.0	13.0	400
FriFri	PL311H31G0	3-phase	15,000		N/A	21.7	21.7	21.7	400
FriFri	PL411L31G0	3-phase	15,000		N/A	21.7	21.7	21.7	400
FriFri	PL411M31G0	3-phase	18,000		N/A	26.1	26.1	26.1	400
FriFri	PL411H31G0	3-phase	22,000		N/A	31.9	31.9	31.9	400
FriFri	PL311L31G0	3-phase	11,400		N/A	16.5	16.5	16.5	400
FriFri	PL412H31G0	3-phase	22,000		N/A	31.9	31.9	31.9	400
FriFri	PL412L31G0	3-phase	15,000		N/A	21.7	21.7	21.7	400
FriFri	PL412M31G0	3-phase	18,000		N/A	26.1	26.1	26.1	400
FriFri	PL422H32G0	3-phase	2 x 11,000		N/A	2 x 15.9	2 x 15.9	2 x 15.9	400
FriFri	PL422H31G0	3-phase	22,000		N/A	31.9	31.9	31.9	400
FriFri	PL422L12G0	1-phase	2 x 7,500	2 x 32.6	230				N/A
FriFri	PL422L31G0	3-phase	22,000		N/A	31.9	31.9	31.9	400
FriFri	PL422L32G0	3-phase	2 x 7,500		N/A	2 x 10.9	2 x 10.9	2 x 10.9	400
FriFri	PL422M12G0	1-phase	2 x 9,000	2 x 39.1	230				N/A
FriFri	PL422M31G0	3-phase	18,000		N/A	26.1	26.1	26.1	400
FriFri	PL422M32G0	3-phase	2 x 9,000		N/A	2 x 13.0	2 x 13.0	2 x 13.0	400
FriFri	PL622H32G0	3-phase	2 x 15,000		N/A	2 x 21.7	2 x 21.7	2 x 21.7	400
FriFri	PL622H31G0	3-phase	30,000		N/A	31.9	31.9	31.9	400
FriFri	PL622L32G0	3-phase	2 x 11,400		N/A	2 x 16.5	2 x 16.5	2 x 16.5	400
FriFri	PL622L31G0	3-phase	33,000		N/A	33	33	33	400
FriFri	PL633L13G0	1-phase	3 x 7,500	3 x 32.6	230				N/A
FriFri	PL633L31G0	3-phase	22,500		N/A	32.6	32.6	32.6	400
FriFri	PL633L33G0	3-phase	3 x 7,500		N/A	3 x 10.9	3 x 10.9	3 x 10.9	400
FriFri	PL633M13G0	1-phase	3 x 9,000	3 x 39.1	230				N/A
FriFri	PL633M31G0	3-phase	27,000		N/A	39.1	39.1	39.1	400
FriFri	PL633H33G0	3-phase	3 x 11,000		N/A	3 x 15.9	3 x 15.9	3 x 15.9	400
FriFri	PL633H31G0	3-phase	33,000		N/A	47.7	47.7	47.7	400
FriFri	PL633M33G0	3-phase	3 x 9,000		N/A	3 x 13.0	3 x 13.0	3 x 13.0	400
FriFri	SD211H31G0	3-phase	11,000		N/A	15.9	15.9	15.9	400
FriFri	SD211H31N0	3-phase	11,000		N/A	15.9	15.9	15.9	400
FriFri	SD211L11G0	1-phase	7,500	32.6	230				N/A
FriFri	SD211L11N0	1-phase	7,500	32.6	230				N/A
FriFri	SD211L31G0	3-phase	7,500		N/A	10.9	10.9	10.9	400
FriFri	SD211L31N0	3-phase	7,500		N/A	10.9	10.9	10.9	400
FriFri	SD311H31G0	3-phase	15,000		N/A	21.7	21.7	21.7	400
FriFri	SD411L31G0	3-phase	15,000		N/A	21.7	21.7	21.7	400
FriFri	SD411H31G0	3-phase	22,000		N/A	31.9	31.9	31.9	400
FriFri	SD311H31N0	3-phase	15,000		N/A	21.7	21.7	21.7	400



Electricity Supply Requirements

Electrical products not listed on this page are supplied for operation on a 230/240v, 13 amp supply.

Brand	Product Code	Power Supply/ Connection Type	Electrical Supply Rating [watts]	Single Phase		Three Phase			
				Amps	Voltage	Amps - Phase 1	Amps - Phase 2	Amps - Phase 3	Voltage
FriFri	SD311L31G0	3-phase	11,400		N/A	16.5	16.5		400
FriFri	SD311L31N0	3-phase	11,400		N/A	16.5	16.5	16.5	400
FriFri	SD412H31G0	3-phase	22,000		N/A	31.9	31.9	31.9	400
FriFri	SD412H31N0	3-phase	22,000		N/A	31.9	31.9	31.9	400
FriFri	SD412L31G0	3-phase	15,000		N/A	21.7	21.7	21.7	400
FriFri	SD412L31N0	3-phase	15,000		N/A	21.7	21.7	21.7	400
FriFri	SD422H32G0	3-phase	2 x 11,000		N/A	2 x 15.9	2 x 15.9	2 x 15.9	400
FriFri	SD422H31G0	3-phase	22,000		N/A	31.9	31.9	31.9	400
FriFri	SD422H32N0	3-phase	2 x 11,000		N/A	2 x 15.9	2 x 15.9	2 x 15.9	400
FriFri	SD422L12G0	1-phase	2 x 7500	2 x 32.6	230			N/A	
FriFri	SD422L31G0	3-phase	15,000		N/A	21.7	21.7	21.7	400
FriFri	SD422L12N0	1-phase	2 x 7500	2 x 32.6	230			N/A	
FriFri	SD422L31G0	3-phase	15,000		N/A	21.7	21.7	21.7	400
FriFri	SD422L31N0	3-phase	15,000		N/A	21.7	21.7	21.7	400
FriFri	SD622H32G0	3-phase	2 x 15,000		N/A	2 x 21.7	2 x 21.7	2 x 21.7	400
FriFri	SD622H31G0	3-phase	30,000		N/A	43.4	43.4	43.4	400
FriFri	SD622H32N0	3-phase	2 x 15,000		N/A	2 x 21.7	2 x 21.7	2 x 21.7	400
FriFri	SD622L32G0	3-phase	2 x 11,400		N/A	2 x 16.5	2 x 16.5	2 x 16.5	400
FriFri	SD622L31G0	3-phase	22,800		N/A	33	33	33	400
FriFri	SD622L32N0	3-phase	2 x 11,400		N/A	2 x 16.5	2 x 16.5	2 x 16.5	400
FriFri	SD633H31N0	3-phase	33,000		N/A	47.8	47.8	47.8	400
FriFri	SD633H33G0	3-phase	3 x 11,000		N/A	3 x 15.9	3 x 15.9	3 x 15.9	400
FriFri	SD633H33N0	3-phase	3 x 11,000		N/A	3 x 15.9	3 x 15.9	3 x 15.9	400
FriFri	SD633L13G0	1-phase	3 x 7,500	3 x 32.6	230			N/A	
FriFri	SD633L13N0	1-phase	3 x 7,500	3 x 32.6	230			N/A	
FriFri	SD633L31G0	3-phase	22,500		N/A	32.6	32.6	32.6	400
FriFri	SD633H31G0	3-phase	33,000		N/A	47.8	47.8	47.8	400
FriFri	SD633L31N0	3-phase	22,500		N/A	32.6	32.6	32.6	400
FriFri	SD633L33G0	3-phase	3 x 7,500		N/A	3 x 10.9	3 x 10.9	3 x 10.9	400
FriFri	SD633L33N0	3-phase	3 x 7,500		N/A	3 x 10.9	3 x 10.9	3 x 10.9	400
FriFri	SL211H31G0	3-phase	11,000		N/A	15.9	15.9	15.9	400
FriFri	SL211H31N0	3-phase	11,000		N/A	15.9	15.9	15.9	400
FriFri	SL211L11G0	1-phase	7500	32.6	230			N/A	
FriFri	SL211L11N0	1-phase	7500	32.6	230			N/A	
FriFri	SL211L31G0	3-phase	7,500		N/A	10.9	10.9	10.9	400
FriFri	SL211L31N0	3-phase	7,500		N/A	10.9	10.9	10.9	400
FriFri	SL311H31G0	3-phase	15,000		N/A	21.7	21.7	21.7	400
FriFri	SL411L31G0	3-phase	15,000		N/A	21.7	21.7	21.7	400
FriFri	SL411H31G0	3-phase	22,000		N/A	31.9	31.9	31.9	400
FriFri	SL311H31N0	3-phase	15,000		N/A	21.7	21.7	21.7	400
FriFri	SL311L31G0	3-phase	11,400		N/A	16.5	16.5	16.5	400
FriFri	SL311L31N0	3-phase	11,400		N/A	16.5	16.5	16.5	400
FriFri	SL412H31G0	3-phase	22,000		N/A	31.9	31.9	31.9	400
FriFri	SL412H31N0	3-phase	22,000		N/A	31.9	31.9	31.9	400
FriFri	SL412L31G0	3-phase	15,000		N/A	21.7	21.7	21.7	400
FriFri	SL412L31N0	3-phase	15,000		N/A	21.7	21.7	21.7	400
FriFri	SL422H32G0	3-phase	2 x 11,000		N/A	2 x 15.9	2 x 15.9	2 x 15.9	400
FriFri	SL422H31G0	3-phase	22,000		N/A	31.9	31.9	31.9	400
FriFri	SL422H32N0	3-phase	2 x 11,000		N/A	2 x 15.9	2 x 15.9	2 x 15.9	400
FriFri	SL422L12G0	1-phase	2 x 7500	2 x 32.6	230			N/A	
FriFri	SL422L31G0	3-phase	15,000		N/A	21.7	21.7	21.7	400
FriFri	SL422L12N0	1-phase	2 x 7500	2 x 32.6	230			N/A	
FriFri	SL422L31G0	3-phase	15,000		N/A	21.7	21.7	21.7	400
FriFri	SL422L31N0	3-phase	15,000		N/A	21.7	21.7	21.7	400
FriFri	SL622H32G0	3-phase	2 x 15,000		N/A	2 x 21.7	2 x 21.7	2 x 21.7	400
FriFri	SL622H31G0	3-phase	30,000		N/A	43.4	43.4	43.4	400
FriFri	SL622H32N0	3-phase	2 x 15,000		N/A	2 x 21.7	2 x 21.7	2 x 21.7	400
FriFri	SL622L32G0	3-phase	2 x 11,400		N/A	2 x 16.5	2 x 16.5	2 x 16.5	400
FriFri	SL622L31G0	3-phase	22,800		N/A	33	33	33	400
FriFri	SL622L32N0	3-phase	2 x 11,400		N/A	2 x 16.5	2 x 16.5	2 x 16.5	400
FriFri	SL633H31N0	3-phase	33,000		N/A	47.8	47.8	47.8	400
FriFri	SL633H33N0	3-phase	3 x 11,000		N/A	3 x 15.9	3 x 15.9	3 x 15.9	400
FriFri	SL633L13G0	1-phase	3 x 7,500	3 x 32.6	230			N/A	
FriFri	SL633L13N0	1-phase	3 x 7,500	3 x 32.6	230			N/A	
FriFri	SL633L31G0	3-phase	22,500		N/A	32.6	32.6	32.6	400
FriFri	SL633H33G0	3-phase	3 x 11,000		N/A	3 x 15.9	3 x 15.9	3 x 15.9	400
FriFri	SL633H31G0	3-phase	33,000		N/A	47.8	47.8	47.8	400
FriFri	SL633L31N0	3-phase	22,500		N/A	32.6	32.6	32.6	400
FriFri	SL633L33G0	3-phase	3 x 7,500		N/A	3 x 10.9	3 x 10.9	3 x 10.9	400
FriFri	SL633L33N0	3-phase	3 x 7,500		N/A	3 x 10.9	3 x 10.9	3 x 10.9	400
FriFri	TD211H31G0	3-phase	11,000		N/A	15.9	15.9	15.9	400
FriFri	TD211L11G0	1-phase	7500	32.6	230			N/A	
FriFri	TD211L31G0	3-phase	7,500		N/A	10.9	10.9	10.9	400
FriFri	TD211M11G0	1-phase	9000	39.1	230			N/A	
FriFri	TD211M31G0	3-phase	9,000		N/A	13.0	13.0	13.0	400
FriFri	TD311H31G0	3-phase	15,000		N/A	21.7	21.7	21.7	400
FriFri	TD311L31G0	3-phase	11,400		N/A	16.5	16.5	16.5	400
FriFri	TD411L31G0	3-phase	15,000		N/A	21.7	21.7	21.7	400
FriFri	TD411M31G0	3-phase	18,000		N/A	26.1	26.1	26.1	400
FriFri	TD411H31G0	3-phase	22,000		N/A	31.9	31.9	31.9	400
FriFri	TD412H31G0	3-phase	22,000		N/A	31.9	31.9	31.9	400
FriFri	TD412L31G0	3-phase	15,000		N/A	21.7	21.7	21.7	400
FriFri	TD412M31G0	3-phase	18,000		N/A	26.1	26.1	26.1	400
FriFri	TD422H32G0	3-phase	2 x 11,000		N/A	2 x 15.9	2 x 15.9	2 x 15.9	400
FriFri	TD422H31G0	3-phase	22,000		N/A	31.9	31.9	31.9	400
FriFri	TD422L12G0	1-phase	2 x 7500	2 x 32.6	230			N/A	
FriFri	TD422L31G0	3-phase	15,000		N/A	21.7	21.7	21.7	400
FriFri	TD422L32G0	3-phase	2 x 7,500		N/A	2 x 10.9	2 x 10.9	2 x 10.9	400
FriFri	TD422M12G0	1-phase	2 x 9000	2 x 39.1	230			N/A	
FriFri	TD422M31G0	3-phase	18,000		N/A	26.1	26.1	26.1	400

All weights stated are packed weights.

Warning UK: In accordance with The Gas Safety (Installation and Use Amendment Regulations 1998) gas appliances must be installed by commercial catering equipment engineers certified by the Gas Safe Register. Failure to comply with this will render any non registered installer liable to prosecution and will invalidate the guarantee.

For Sale terms and conditions please visit lincat.co.uk/sale-terms-conditions

Electricity Supply Requirements

Electrical products not listed on this page are supplied for operation on a 230/240v, 13 amp supply.

Brand	Product Code	Power Supply/ Connection Type	Electrical Supply Rating [watts]	Single Phase		Three Phase			
				Amps	Voltage	Amps - Phase 1	Amps - Phase 2	Amps - Phase 3	Voltage
FriFri	TD422M32G0	3-phase	2 x 9,000	N/A		2 x 13.0	2 x 13.0	2 x 13.0	400
FriFri	TD522L32G0	3-phase	11,400; 7,500	N/A		16.5 + 10.9	16.5 + 10.9	16.5 + 10.9	400
FriFri	TD522M32G0	3-phase	11,400; 9,000	N/A		16.5 + 13.0	16.5 + 13.0	16.5 + 13.0	400
FriFri	TD622H32G0	3-phase	2 x 15,000	N/A		2 x 21.7	2 x 21.7	2 x 21.7	400
FriFri	TD622H31G0	3-phase	30,000	N/A		43.4	43.4	43.4	400
FriFri	TD622L32G0	3-phase	2 x 11,400	N/A		2 x 16.5	2 x 16.5	2 x 16.5	400
FriFri	TD622L31G0	3-phase	22,800	N/A		33	33	33	400
FriFri	TD633L13G0	1-phase	3 x 7,500	3 x 32.6	230			N/A	
FriFri	TD633L31G0	3-phase	22,500	N/A		32.6	32.6	32.6	400
FriFri	TD633L33G0	3-phase	3 x 7,500	N/A		3 x 10.9	3 x 10.9	3 x 10.9	400
FriFri	TD633M13G0	1-phase	3 x 9,000	3 x 39.1	230			N/A	
FriFri	TD633M31G0	3-phase	27,000	N/A		32.6	32.6	32.6	400
FriFri	TD633H33G0	3-phase	33,000	N/A		47.7	47.7	47.7	400
FriFri	TD633H31G0	3-phase	3 x 11,000	N/A		3 x 15.9	3 x 15.9	3 x 15.9	400
FriFri	TD633M33G0	3-phase	3 x 9,000	N/A		3 x 10.9	3 x 10.9	3 x 10.9	400
FriFri	TL211H31G0	3-phase	11,000	N/A		15.9	15.9	15.9	400
FriFri	TL211L11G0	1-phase	7500	32.6	230			N/A	
FriFri	TL211L31G0	3-phase	7,500	N/A		10.9	10.9	10.9	400
FriFri	TL211M11G0	1-phase	9000	39.1	230			N/A	
FriFri	TL211M31G0	3-phase	9,000	N/A		13.0	13.0	13.0	400
FriFri	TL311H31G0	3-phase	15,000	N/A		21.7	21.7	21.7	400
FriFri	TL411L31G0	3-phase	15,000	N/A		21.7	21.7	21.7	400
FriFri	TL411M31G0	3-phase	18,000	N/A		26.1	26.1	26.1	400
FriFri	TL411H31G0	3-phase	22,000	N/A		31.9	31.9	31.9	400
FriFri	TL311L31G0	3-phase	11,400	N/A		16.5	16.5	16.5	400
FriFri	TL412H31G0	3-phase	22,000	N/A		31.9	31.9	31.9	400
FriFri	TL412L31G0	3-phase	15,000	N/A		21.7	21.7	21.7	400
FriFri	TL412M31G0	3-phase	18,000	N/A		26.1	26.1	26.1	400
FriFri	TL422H32G0	3-phase	2 x 11,000	N/A		2 x 15.9	2 x 15.9	2 x 15.9	400
FriFri	TL422H31G0	3-phase	22,000	N/A		31.9	31.9	31.9	400
FriFri	TL422L12G0	1-phase	2 x 7500	2 x 32.6	230			N/A	
FriFri	TL422L31G0	3-phase	15,000	N/A		21.7	21.7	21.7	400
FriFri	TL422L32G0	3-phase	2 x 7,500	N/A		2 x 10.9	2 x 10.9	2 x 10.9	400
FriFri	TL422M12G0	1-phase	2 x 9000	2 x 39.1	230			N/A	
FriFri	TL422M31G0	3-phase	18,000	N/A		26.1	26.1	26.1	400
FriFri	TL422M32G0	3-phase	2 x 9,000	N/A		2 x 13.0	2 x 13.0	2 x 13.0	400
FriFri	TL622H32G0	3-phase	2 x 15,000	N/A		2 x 21.7	2 x 21.7	2 x 21.7	400
FriFri	TL622H31G0	3-phase	30,000	N/A		26.1	26.1	26.1	400
FriFri	TL622L32G0	3-phase	2 x 11,400	N/A		2 x 16.5	2 x 16.5	2 x 16.5	400
FriFri	TL622L31G0	3-phase	22,800	N/A		33	33	33	400
FriFri	TL633L13G0	1-phase	3 x 7,500	3 x 32.6	230			N/A	
FriFri	TL633L31G0	3-phase	22500	N/A		32.6	32.6	32.6	400
FriFri	TL633L33G0	3-phase	3 x 7,500	N/A		3 x 10.9	3 x 10.9	3 x 10.9	400
FriFri	TL633M13G0	1-phase	3 x 9,000	3 x 39.1	230			N/A	
FriFri	TL633M31G0	3-phase	27000	N/A		32.6	32.6	32.6	400
FriFri	TL633M33G0	3-phase	3 x 9,000	N/A		3 x 10.9	3 x 10.9	3 x 10.9	400
FriFri	TL633H33G0	3-phase	3 x 11,000	N/A		3 x 15.9	3 x 15.9	3 x 15.9	400
FriFri	TL633H31G0	3-phase	33,000	N/A		47.7	47.7	47.7	400

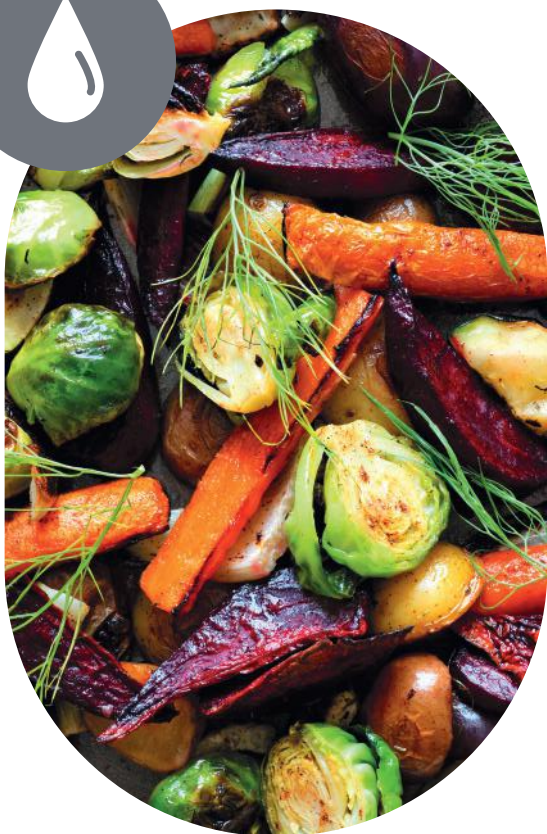

imc

2026 PRICE LIST



SPECIALISING IN

- BAR SYSTEMS
- VEGETABLE PREPARATION
- WASTE MANAGEMENT
- CLEANING AND RINSING

imc

lincat.co.uk

2026

Contents

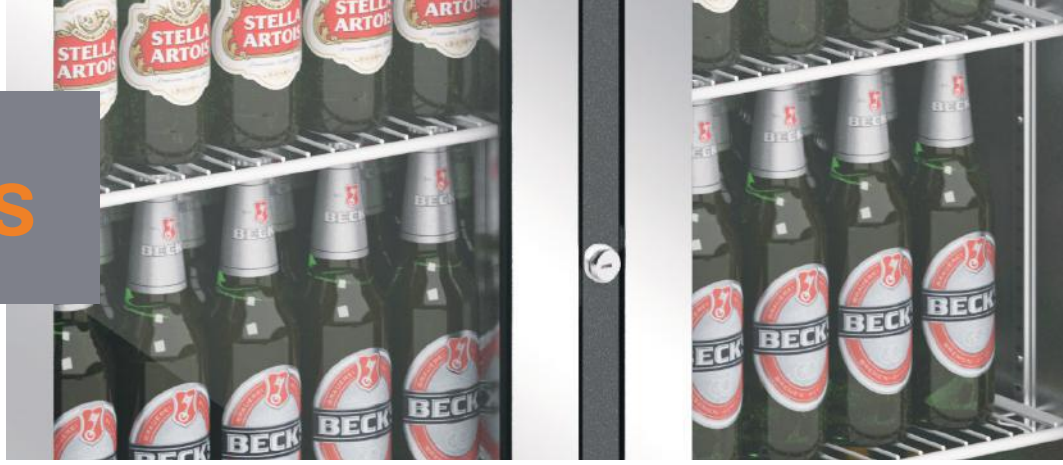

Bar Systems and Refrigeration

Under Bar Systems, Bottle Coolers and Glass Frosters

Ideally suited for:

Bars, restaurants, hotels, cafes and coffee shops: Speed up service and generate customer satisfaction with great-tasting drinks.

Why choose IMC Under Bar Systems, Bottle Coolers and Glass Frosters?

- Maximise serving speed and efficiency
- Bartender's wide range of modules and accessories are available to meet all your needs
- Great tasting drinks
- Quick and easy access
- Energy efficient models
- Choice of exterior colours and door options
- Available in a variety of sizes to suit the scale of your operation

Find out more on page

i3



Vegetable Preparation

Peelers and Chippers

Ideally suited for:

Fish and chip shops, pubs, restaurants and fast food outlets, prepare a high volume of vegetables at speed with IMC's vegetable preparation solutions.

Why choose IMC Vegetable Preparation Equipment?

- Peel and prepare vegetables at speed
- Increase the efficiency of your kitchen
- Simple and safe to operate
- Easy to load
- Easy to maintain
- Easy to clean
- Robustly engineered
- Provides minimal waste

Find out more on page

i59



Waste Management

Food Waste Disposers and Waste Compactors

Ideally suited for:

Pubs & bars, nursing homes, hospitals and factories. Create a cleaner, safer working environment and save time and money, by investing in efficient waste management equipment.

Why choose IMC Waste Management Equipment

- Compact and efficient
- Remove waste quickly
- Safe and easy operation
- Reduces costs, saves time

Find out more on page

i75



Cleaning and Rinsing

Pan Scrubbers and Mobile Cleansing Stations

Ideally suited for:

Restaurants and cafes, outdoor catering, cost sector: meet stringent hygiene standards and save valuable staff time, with effective cleaning and rinsing solutions.

Why choose IMC Cleaning and Rinsing Equipment?

- Effective removal of food debris
- Saves time and increases efficiency
- Safe and easy to use
- Ideal for organisations looking to extend hand washing facilities
- Helps meet health and safety, and hygiene standards

Find out more on page

i93

All prices are exclusive of VAT.

UK

Goods are normally delivered free of charge to either the dealers' address or direct within 3 working days. If overnight and/or premium services are required charges will apply.

Export

Goods are priced ex works, export crates POA.

Any units which are built to order or include factory fit options are non-returnable.

☎ UK Tel: 01522 875500

☎ Export Tel: +44 1522 503250

✉ UK e-mail: sales@lincat.co.uk

✉ Export e-mail: export@lincat.co.uk



2
YEAR

UK parts and labour warranty

Export parts warranty

on all IMC products

Bar Systems & Refrigeration

Under Bar Systems • Bottle coolers • Glass Frosters



Our comprehensive range of commercial under bar and refrigeration equipment is designed to meet the needs of every restaurant, bar and café regardless of shape, size or budget.

The bar-workstation concept is unique to IMC and epitomised in Bartender, our under bar system. From draught pumps to cocktail ingredients, glasses to cash till, everything is ergonomically positioned to minimise movement of bar staff and maximise serving speed and efficiency.

With precise temperature control and rapid chill, our energy-efficient bottle coolers are the perfect showcase for drinks. Across three ranges - Ventus, Mistral and BM - all models allow easy access

for quick service and are available in a range of stylish designs and space-saving sizes.

With rapid chill, our energy-efficient range of glass frosters helps bars to deliver high-quality drinks every time. With three ranges to choose from - Ventus, Mistral and Frostar - each froster provides easy access for quick service and is available in a range of sleek designs, with varying capacities.

Ideally suited for...



Bars

Speed up service and generate customer satisfaction with efficient service and great tasting drinks.



Restaurants

Enhance your customers' dining experience by serving high-quality drinks alongside delicious food.



Hotels

Attract customers in your hotel's bar with great service, stylish bottle coolers and glass frosters. Show your drinks in their best light in a well-designed unit that enhances your offer.



Cafes and coffee shops

Encourage customers to spend by tempting them with well-presented drinks. Highlight your offer and ensure great tasting beverages with a Mistral bottle cooler.

Benefits at a glance

- Maximise serving speed and efficiency
- Bartender's wide range of modules and accessories are available to meet all your needs
- Energy efficient coolers with rapid chill for quick service
- Bottle coolers and frosters available in a choice of exterior colours and door options

Bottle Coolers

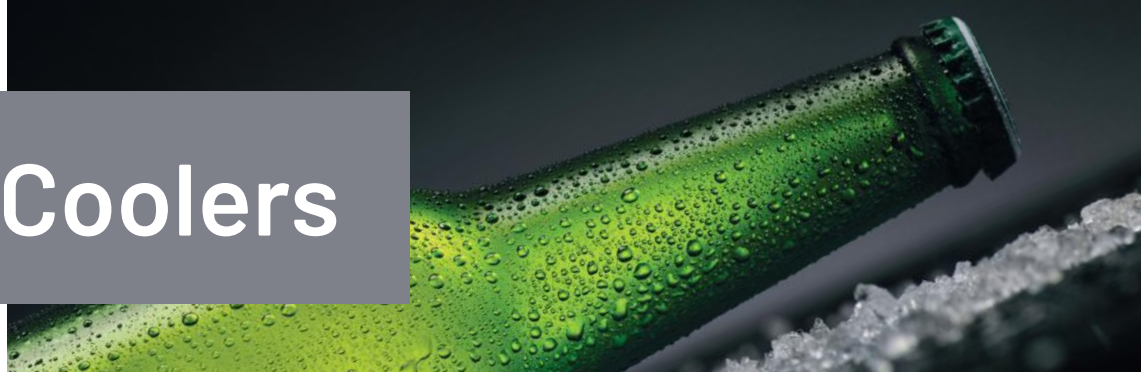

	Ventus						Mistral						BM	BM Bartender
	V60	V60 (FULL FRONT)	V90	V90 (FULL FRONT)	V135	V135 (FULL FRONT)	M60	M60 (HIGH AMBIENT)	M90	M90 (HIGH AMBIENT)	M135	TC60	BM70	BM70
PAGE	i20 - i23	i24 - i27	i28 - i31	i32 - i35	i36 - i37	i38 - i39	i46	i47	i48	i50	i51	i52	i56	i56
DIMENSIONS														
HEIGHT (mm)	900/850/ 800	900/850/ 800	900/850/ 800	900/850/ 800	900/800	900/800	900/850/ 800	900	900/850/ 800	900	900/800	1850	875	950
WIDTH (mm)	600	600	900	900	1350	1350	600	600	900	900	1350	600	700	700
DEPTH (mm)	500/450	500	500/450	500	500	500	500	500	500	500	500	500	560	560
ACCESS														
SIDE LOADING	✓	✓	✓	✓	✓	✓	✓	✓	✓	✓	✓	✓	-	-
TOP LOADING	-	-	-	-	-	-	-	-	-	-	-	-	✓	✓
BOTTLE CAPACITY														
800mm HIGH	78	78	117	117	185	185	78	-	117	-	185	-	-	-
850mm HIGH	78	78	117	117	-	-	78	-	117	-	-	-	-	-
900mm HIGH (SIDE OPENING)	120	120	195	195	310	310	120	-	195	-	310	-	-	-
900mm HIGH (SLIDING DOOR)	-	-	-	-	-	-	-	-	204	-	-	-	-	-
450mm DEPTH	96	96	156	156	-	-	-	-	-	-	-	-	-	-
HIGH AMBIENT	-	-	-	-	-	-	135	136	204	204	-	-	-	-
1850mm HIGH	-	-	-	-	-	-	-	-	-	-	-	272	-	-
BM/BM BARTENDER	-	-	-	-	-	-	-	-	-	-	-	-	140	140
DOOR/S														
NUMBER OF DOORS	1	1	2	2	3	3	1	1	2	3	3	1	2	2
DOOR OPENING	Front	Front	Front	Front	Front	Front	Front	Front	Front	Front	Front	Front	Top	Top
DOOR HINGING	Right, revers- ible	Right, revers- ible	Left, Right	Left, Right	Left, Right, Right	Left, Right, Right	Right	Right	Left, Right	Left, Right	Left, Right, Right	Right, revers- ible	-	-
SLIDING DOOR MODEL	-	-	-	-	-	-	-	-	✓	-	-	-	-	-
DOOR FINISH														
STAINLESS STEEL	✓	✓	✓	✓	✓	✓	✓	✓	✓	✓	✓	✓	✓	✓
BLACK PAINTED	✓	✓	✓	✓	✓	✓	✓	-	✓	-	✓	✓	-	-
GLAZED DOOR OPTION	✓	✓	✓	✓	✓	✓	✓	✓	✓	✓	✓	✓	✓	✓
SOLID DOOR OPTION	✓	✓	✓	✓	✓	✓	-	✓	-	✓	-	✓	✓	✓
ACCEPTS CUSTOMERS OWN DOOR PANEL	✓	✓	✓	✓	✓	✓	-	-	-	-	-	✓	-	-
NUMBER OF SHELVES	2	2	2	2	2	2	2	2	2	2	2	5	2	2
NUMBER OF SHELF POSITIONS	29	29	29	29	29	29	29	29	29	29	29	95	2	2
WINE SHELF AVAILABLE	✓	✓	✓	✓	✓	✓	✓	✓	✓	✓	✓	✓	-	-
ADJUSTABLE OPERATING TEMPERATURE	2°C - 6°C	2°C - 6°C	2°C - 6°C	2°C - 6°C	2°C - 6°C	2°C - 6°C	2°C - 6°C	2°C - 6°C	2°C - 6°C	2°C - 6°C	2°C - 6°C	2°C - 6°C	2°C - 6°C	2°C - 6°C
INTERNAL LIGHTING	LED	LED	LED	LED	LED	LED	LED	LED	LED	LED	LED	LED	0	0
LOCK	✓	-	✓	-	✓	-	✓	✓	✓	✓	✓	✓*	✓	✓
BARTENDER COMPATIBLE	-	-	-	-	-	-	-	-	-	-	-	-	-	✓
REFRIGERANT TYPE	R290	R290	R290	R290	R290	R290	R290	R290	R290	R290	R290	R290	R290	R290

*Only on F77/510 Models

2
YEAR

UK parts
and labour
warranty

Export
parts
warranty

on all IMC products

Glass Frosters



	Ventus		Frostar
	VR60	VR60 (FULL FRONT)	FR60
PAGE	i40	i42	i58
DIMENSIONS			
HEIGHT (mm)	900/800	900/800	900
WIDTH (mm)	600	600	600
DEPTH (mm)	500	500	620
ACCESS			
SIDE LOADING	✓	✓	-
TOP LOADING	-	-	✓
GLASS CAPACITY (STANDARD PINT GLASS)			
800mm HIGH	50	50	-
900mm HIGH (SIDE OPENING DOORS)	50	50	-
900mm HIGH (TOP OPENING DOORS)	-	-	75
DOOR/S			
NUMBER OF DOORS	1	1	1
DOOR OPENING	Front	Front	Top
DOOR HINGING	Right, reversible	Right, reversible	-
DOOR FINISH			
STAINLESS STEEL	✓	✓	✓
BLACK PAINTED	✓	✓	✓
GLAZED DOOR OPTION	✓	✓	-
SOLID DOOR OPTION	✓	✓	-
ACCEPTS CUSTOMERS OWN DOOR PANEL	-	✓	-
NUMBER OF SHELVES			
NUMBER OF SHELVES	2	2	3
NUMBER OF SHELF POSITIONS	29	29	2
WINE SHELF AVAILABLE	✓	✓	-
OPERATING TEMPERATURE	-10°C Constant	-10°C Constant	-17°C Constant
INTERNAL LIGHTING	LED	LED	Fluorescent
LOCK			
LOCK	✓	✓	✓
REFRIGERANT TYPE			
REFRIGERANT TYPE	R290	R290	R290

2 YEAR
UK parts and labour warranty | Export parts warranty
on all IMC products

Contents



Bartender

Ergonomically equip bar staff to serve drinks in the most efficient way

Under Bar System

Ideally suited for:

Bars, restaurants and hotels. Speed up service and generate customer satisfaction with efficient service.

Why choose Bartender?

- Configured to maximise staff productivity and efficiency
- Boosts sales and improves profits
- Easy to clean and robust stainless steel construction
- A wide range of work stations, modules and accessories are available to meet all your needs
- Ensures your bar area conforms to Food Safety Regulations

Find out more on page **i7**



Ventus

The bespoke nature of Ventus makes it the ideal choice for a wide range of operations.

Bottle Coolers and Glass Frosters

Ideally suited for:

Clubs, hotels, cafes and coffee shops serve ice cold drinks with visual appeal with Ventus.

Why choose Ventus?

- Precise temperature control ensures drinks are kept at the optimum serving temperature
- Variety of space-saving sizes available, we're sure to have a solution perfect for any available space.
- Over 150 options available including lighting options, door finishes, handle options and gas types ensures we have a design to complement every bar setting.
- Economical running with the Dynamic Air Distribution System, and EcoSmart controller

Find out more on page **i17**



Mistral

With a choice of sizes and exterior finishes, there's a Mistral to suit any bar operation.

Bottle Coolers and Glass Frosters

Ideally suited for:

Bars, restaurants, clubs, hotels, cafes and coffee shops

Why choose Mistral?

- Precise temperature control and rapid chill ensures drinks are kept at the optimum serving temperature
- Perfect showcase for drinks - available in a range of designs and space-saving sizes
- Energy efficient

Find out more on page **i45**



bm

BOTTLE COOLERS

Serve perfectly-chilled drinks at speed with BM's top-loading bottle coolers.

Top-loading Bottle Coolers

Ideally suited for:

Bars, restaurants and clubs

Why choose BM?

- Top-loading design with sliding cover, ensures fast and easy access to ice cold drinks
- Rapid chill for quick service
- Precise temperature control
- Energy efficient
- UK 3 pin plug
- Stylish exterior design for underbar systems

Find out more on page **i55**



Frostar

Serve perfectly-presented, great-tasting drinks with speed with Frostar glass frosters

Top-loading Glass Frosters

Ideally suited for:

Bars, restaurants and clubs

Why choose Frostar?

- Top-loading with sliding cover for quick and easy access
- Chills and frosts glasses to add visual appeal to drinks
- Rapid cooling to -17°C
- Precise temperature control
- Stylish exterior design
- Large capacity

Find out more on page **i57**

Bartender



It may be invisible to customers but they'll see the difference in faster service, less harassed staff and an all-round better atmosphere.

Bartender provides an exciting opportunity to develop a dynamic, versatile and exciting under bar system. Configured to maximise staff productivity and efficiency – and therefore turnover of customers – Bartender boosts sales and improves profits.

The bar-workstation concept is unique to IMC and epitomised in Bartender. From draught pumps to cocktail ingredients, glasses to cash till, everything is ergonomically positioned to minimise movement of bar staff and maximise serving speed and efficiency.

Stainless steel is not only the most stylish solution available for an under bar system. It's also the most practical. Easy to clean and maintain, it can take the knocks in the busiest bars and stay looking pristine.

Central to the successful use of Bartender is the IMC concept of creating compact self-contained workstations. Each area then has everything required by individual bar staff, so they are instantly more efficient and productive. Keep this philosophy in mind when planning a Bartender bar, as it will help you reduce staff costs and boost sales.

Ideally suited for...



Bars

Speed up service and generate customer satisfaction with efficient service.



Restaurants

Enhance your customers' dining experience by serving high-quality drinks alongside delicious food.



Hotels

Attract customers in your hotel's bar with cocktails and great service!

Benefits at a glance

- Configured to maximise staff productivity and efficiency
- Boosts sales and improves profits
- A wide range of work stations, modules and accessories are available to meet all your needs
- Easy to clean and robust stainless steel construction
- Ensures your bar area conforms to Food Safety Regulations



Bartender

Endless possibilities in bar design

The Bartender section within this brochure is designed to provide an introduction to the choice of bar modules, options and accessories we offer. Whether your requirement for a bar is large or small our team of experienced in house designers are here to help develop the perfect bar solution for you.

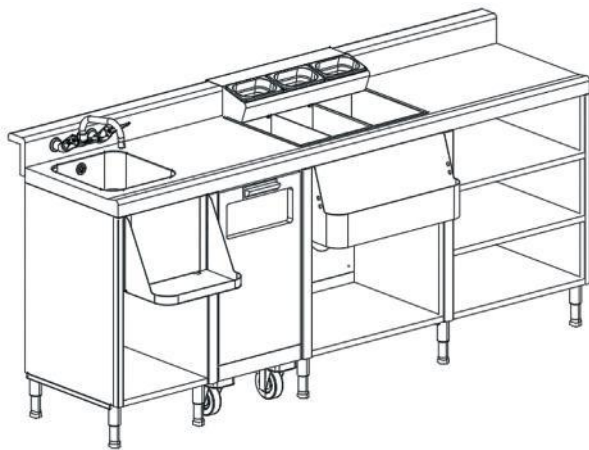

General Work Station

Single piece worktop incorporating an ice chest with speedrail and condiment set, waste unit, perforated top shelf unit and sink unit.

*Additional leg and single trims required.

MODEL	PRICE £	PRICE €	H	D
BZ71/200	£6263	€7203	950	560

Cocktail Station

Single piece worktop incorporating a sink with blender shelf, waste unit, ice well with speedrail and condiment set, and shelf unit.

*Additional leg and single trims required.

MODEL	PRICE £	PRICE €	H	D
BZ70/200	£6289	€7233	950	560



2 YEAR UK parts and labour warranty | Export parts warranty
on all IMC products

Shelf Units & Beer Station

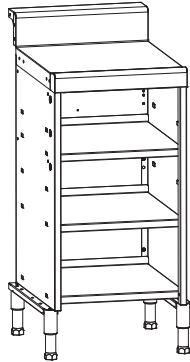

Plain Top Shelf Unit					
MODEL	PRICE £	PRICE €	H	W	D
BZ15/030	£1179	€1356	950	300	560
BZ15/040	£1192	€1371	950	400	560
BZ15/050	£1229	€1413	950	500	560
BZ15/060	£1256	€1444	950	600	560
BZ15/080	£1315	€1513	950	800	560
BZ15/100	£1381	€1589	950	1000	560

Capacity of up to 200 pint (60cl) glasses per metre.

Accessories

MODEL	PRICE £	PRICE €	DESCRIPTION
A BB75/030	£POA	€POA	Door - W 300 mm, to fit BZ15/030
A BB75/040	£POA	€POA	Door - W 400 mm, to fit BZ15/040
A BB75/050	£POA	€POA	Door - W 500 mm, to fit BZ15/050
A BB75/060	£POA	€POA	Door - W 600 mm, to fit BZ15/060
A BB75/080	£POA	€POA	Door - W 800 mm, to fit BZ15/080
A BB75/100	£POA	€POA	Door - W 1000 mm, to fit BZ15/100

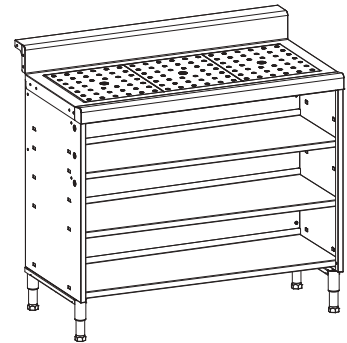
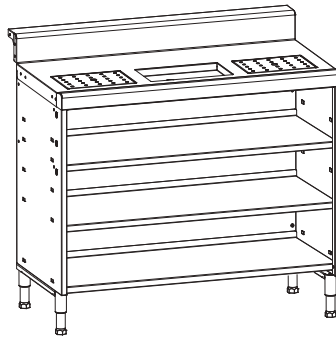
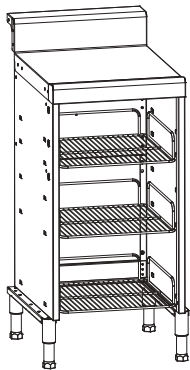

Plain Top Shelf Unit - Wire Shelves					
MODEL	PRICE £	PRICE €	H	W	D
BZ37/040	£1192	€1371	950	400	560
BZ37/050	£1229	€1413	950	500	560
BZ37/060	£1256	€1444	950	600	560
BZ37/080	£1351	€1513	950	800	560
BZ37/100	£1381	€1589	950	1000	560

Capacity of up to 200 pint (60cl) glasses per metre.

Perforated Top Shelf Unit					
MODEL	PRICE £	PRICE €	H	W	D
BZ69/040	£1347	€1550	950	400	560
BZ69/060	£1436	€1651	950	600	560
BZ69/080	£1525	€1755	950	800	560
BZ69/100	£1613	€1855	950	1000	560

Perforated Beer Font Top Shelf Unit					
MODEL	PRICE £	PRICE €	H	W	D
BZ69/040/BF	£1472	€1693	950	400	560
BZ69/060/BF	£1561	€1796	950	600	560
BZ69/080/BF	£1647	€1895	950	800	560
BZ69/100/BF	£1736	€1998	950	1000	560

For mounting of beer fonts

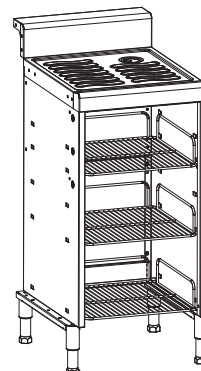
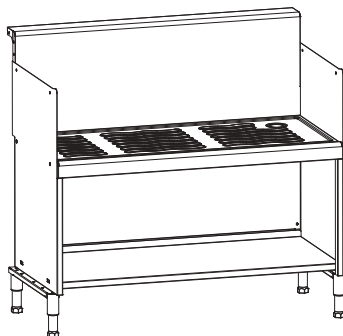

Perforated Top Shelf Unit					
MODEL	PRICE £	PRICE €	H	W	D
BZ34/040	£1482	€1704	950	400	560
BZ34/060	£1526	€1756	950	600	560
BZ34/080	£1579	€1816	950	800	560
BZ34/100	£1619	€1862	950	1000	560

Drainer is 600mm above floor, to accommodate low level beer pumps. Supplied with 11/4" waste trap.

Shelf Drainer Unit - Wire Shelves					
MODEL	PRICE £	PRICE €	H	W	D
BZ38/040	£1280	€1472	950	400	560
BZ38/060	£1347	€1550	950	600	560
BZ38/080	£1408	€1619	950	800	560
BZ38/100	£1472	€1693	950	1000	560

As BZ37, but with a pressed drainer top. Supplied with 11/4" waste trap

Dimensions represent the full unit including splashback.

Bartender

Ice Wells

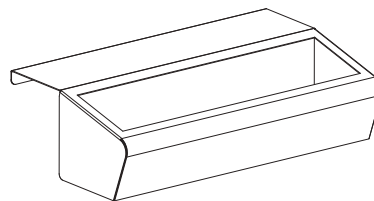
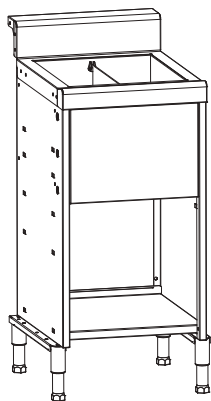

Ice Chest					
MODEL	PRICE £	PRICE €	H	W	D
BZ53/040	£1475	€1697	950	400	560
BZ53/060	£1630	€1875	950	600	560
BZ53/080	£1824	€2098	950	800	560
BZ53/100	£2017	€2320	950	1000	560

Accessories				
MODEL	PRICE £	PRICE €	DESCRIPTION	
A BB74/040	£POA	€POA	Ice Chest Cover, to fit BZ53/040	
A BB74/060	£POA	€POA	Ice Chest Cover, to fit BZ53/060	
A BB74/080	£POA	€POA	Ice Chest Cover, to fit BZ53/080	
A BB74/100	£POA	€POA	Ice Chest Cover, to fit BZ53/100	

Condiment Set				
MODEL	PRICE £	PRICE €	GN Capacity	W
BB53/035	£209	€241	2 x 1/9 x 65mm GN containers	350
BB53/052	£236	€273	3 x 1/9 x 65mm GN containers	525

Hangs on splashback

Supplied complete with removable dividers, drain trays and 11/4 waste trap

Speed Rail

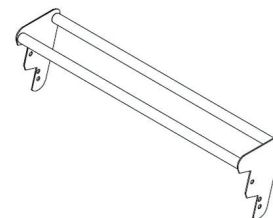
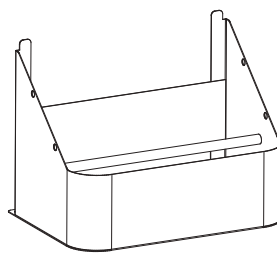
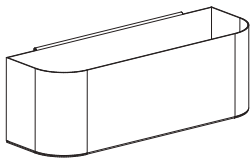
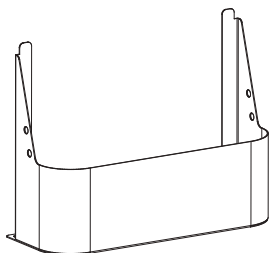

Speed Rail					
MODEL	PRICE £	PRICE €	H	W	D
BB52/040	£203	€234	275	400	135
BB52/060	£219	€252	275	600	135
BB52/080	£230	€265	275	800	135
BB52/100	£241	€277	275	1000	135

Add-on Speed Rail					
MODEL	PRICE £	PRICE €	H	W	D
BB57/040	£228	€262	120	400	110
BB57/060	£240	€276	120	600	110
BB57/080	£253	€291	120	800	110
BB57/100	£266	€307	120	1000	110

Double Speed Rail					
MODEL	PRICE £	PRICE €	H	W	D
BB69/040	£418	€481	275	400	220
BB69/060	£447	€514	275	600	220
BB69/080	£471	€543	275	800	220
BB69/100	£493	€568	275	1000	220

Speed Rail Lock					
MODEL	PRICE £	PRICE €	H	W	D
BB68/040	£100	€115	110	400	80
BB68/060	£106	€123	110	600	80
BB68/080	£114	€131	110	800	80
BB68/100	£125	€144	110	1000	80

Used on ice chests, sinks and worktop

Attached to front of BB52 to double capacity.

Used on single and double speed rails

Accessories

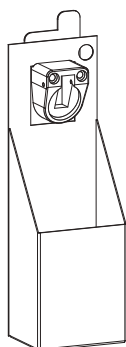

Ice Chest with Covers					
MODEL	PRICE £	PRICE €	H	W	D
BB55/001	£90	€103	260	80	60

Can be fitted to ice chests, sinks or worktops. Includes catcher

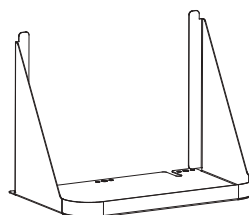

Blender Shelf				
MODEL	PRICE £	PRICE €	W	D
BB51/040	£195	€225	400	210
BB51/043	£195	€225	400	230
BB51/060	£208	€240	600	210
BB51/063	£208	€240	600	230

Use on sinks, ice chest, corner units or worktops

Sinks

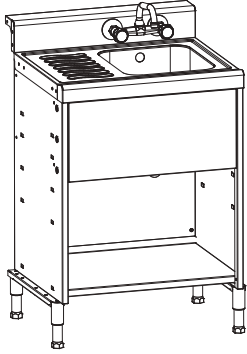

Sink Unit					
MODEL	PRICE £	PRICE €	H	W	D
BZ51/030	£1280	€1472	950	300	560
BZ51/040	£1280	€1472	950	400	560
BZ51/060	£1336	€1536	950	600	560
BZ51/080	£1381	€1589	950	800	560
BZ51/100	£1436	€1651	950	1000	560

BZ51/040 has no drainer, other sizes have left hand drainer. All have mixer tap and 1 1/4" waste trap. Optional door. Soap dispense also available

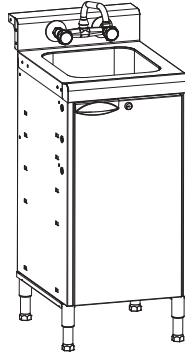

Sink Unit with Door					
MODEL	PRICE £	PRICE €	H	W	D
BZ55/040	£1360	€1565	950	400	560
BZ55/060	£1436	€1651	950	600	560

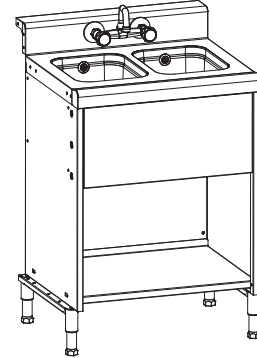

Double Sink Unit					
MODEL	PRICE £	PRICE €	H	W	D
BZ52/060	£1517	€1746	950	600	560
BZ52/080	£1561	€1796	950	800	560
BZ52/100	£1613	€1855	950	1000	560

BZ52/060, BZ52/080 have no drainer. BZ52/100 has left hand drainer. One mixer tap set and a 1 1/4" waste trap supplied.

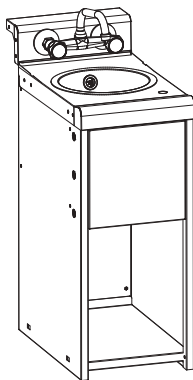

Hand Wash					
MODEL	PRICE £	PRICE €	H	W	D
BZ50/031	£1280	€1472	950	300	560
BZ50/041	£1328	€1527	950	400	560

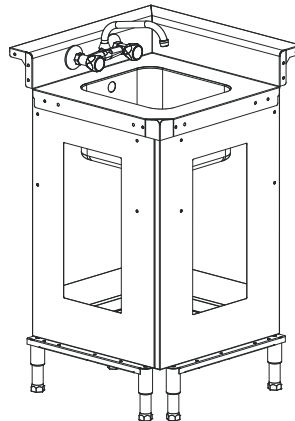

Corner Hand Wash					
MODEL	PRICE £	PRICE €	H	W	D
BZ09/037	£1008	€1159	950	560	560

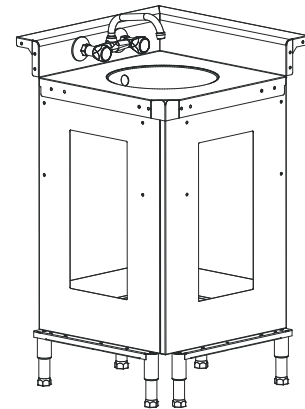

Corner Sink Unit					
MODEL	PRICE £	PRICE €	H	W	D
BZ09/038	£1208	€1391	950	560	560

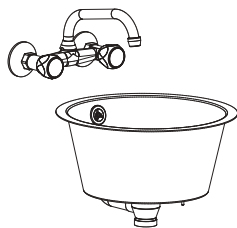

Drop-in Hand Wash Basin			
MODEL	PRICE £	PRICE €	W
BB63/001	£420	€483	305

Can be inset into worktops, plain bridges or custom made infills. Supplied with mixer tap set and 1 1/4" waste trap.

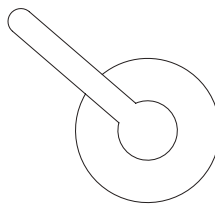

Soap Dispenser		
MODEL	PRICE £	PRICE €
BB64/001	£70	€81

Pre-fitted on request For inserting into hand wash unit.

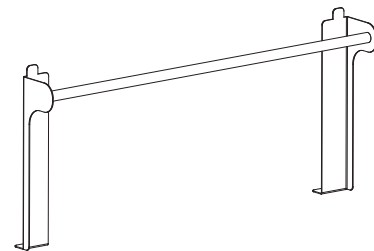

Towel Rail				
MODEL	PRICE £	PRICE €	W	D
BB50/040	£101	€117	400	60
BB50/060	£110	€127	600	60
BB50/080	£120	€137	800	60
BB50/100	£125	€144	1000	60

Used on sinks, hand wash units, corner units, worktops and ice chests.

Bartender

Waste Units

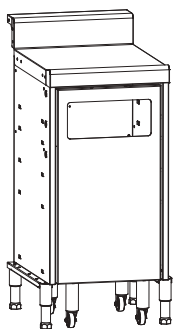

Waste Unit					
MODEL	PRICE £	PRICE €	H	W	D
BZ60/040	£1097	€1262	950	400	560

Wheeled waste unit supplied with bin.

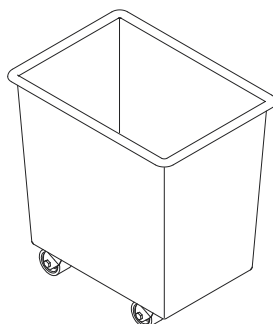

Bottle Skips					
MODEL	PRICE £	PRICE €	H	W	D
BC13/001	£247	€284	695	460	650
BC13/002	£249	€287	510	460	460
BC13/003	£263	€303	620	670	615



Waste Unit					
MODEL	PRICE £	PRICE €	H	W	D
BZ40/040	£1687	€1940	950	400	560

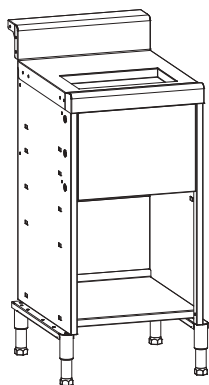

Glass Refresher					
MODEL	PRICE £	PRICE €	H	W	D
BZ50/043	£1182	€1360	950	400	560

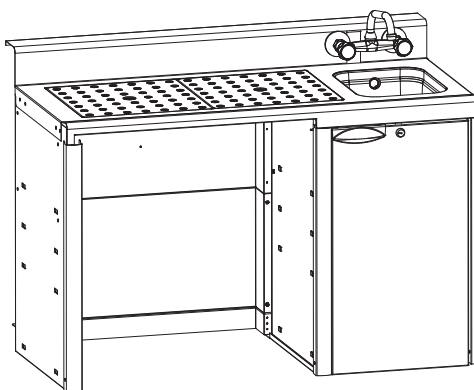

Glass Washer Station					
MODEL	PRICE £	PRICE €	H	W	D
BZ63/110	£1886	€2170	950	1100	560

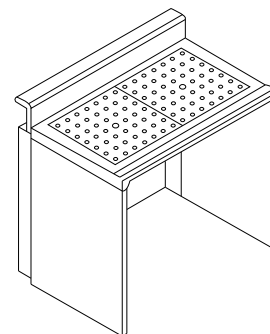

Glasswash Worktop					
MODEL	PRICE £	PRICE €	H	W	D
BZ15/104	£1620	€1863	950	800	560

Basket Racks

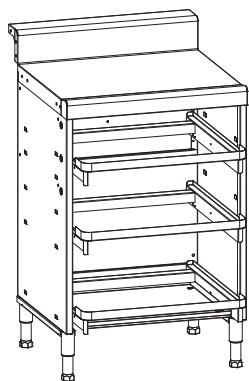

Basket Rack						
MODEL	PRICE £	PRICE €	FOR BASKET WIDTH	H	W	D
BZ23/045	£1374	€1581	For 400mm wide baskets	950	450	560
BZ23/050	£1374	€1581	For 450mm wide baskets	950	505	560
BZ23/055	£1374	€1581	For 500mm wide baskets	950	555	560

Holds three 400, 450 or 500mm wide glasswasher baskets.

Drawer Units

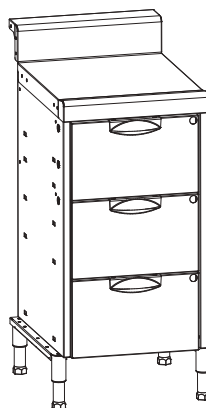

Three Drawer Unit					
MODEL	PRICE £	PRICE €	H	W	D
BZ64/040	£1687	€1940	950	400	560
BZ64/060	£1773	€2040	950	600	560

All drawers lockable individually.

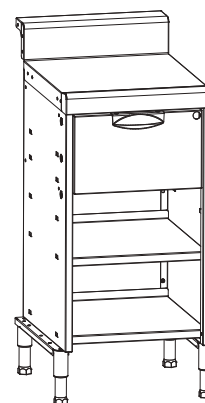

Single Drawer Unit					
MODEL	PRICE £	PRICE €	H	W	D
BZ66/040	£1360	€1565	950	400	560
BZ66/060	£1395	€1605	950	600	560

All drawers lockable individually.

Tiered Spirit Rack

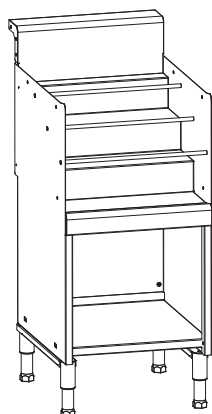

Tiered Spirit Rack

MODEL	PRICE £	PRICE €	H	W	D
BZ75/040	£1135	€1306	950	400	560
BZ75/060	£1255	€1443	950	600	560
BZ75/080	£1408	€1619	950	800	560

Till Units

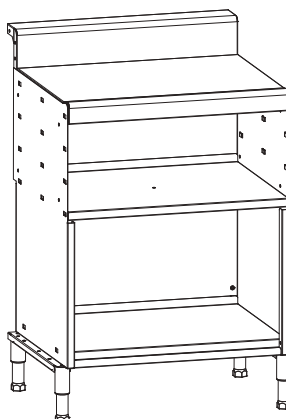

Adjustable Till Unit

MODEL	PRICE £	PRICE €	H	W	D
BZ67/060	£1072	€1232	950	600	560

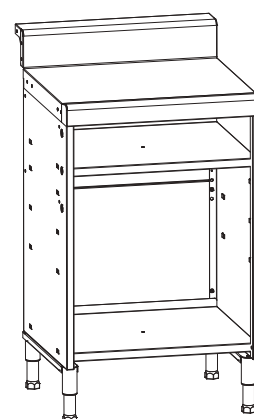

Till Unit

MODEL	PRICE £	PRICE €	H	W	D
BZ67/055	£1072	€1232	950	520	560

Corner Units

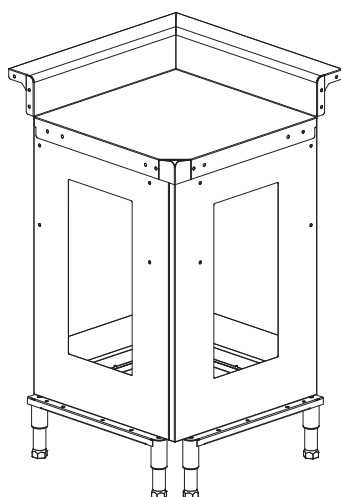

Plain Corner Unit

MODEL	PRICE £	PRICE €	H	W	D
BZ09/039	£1049	€1206	950	560	560

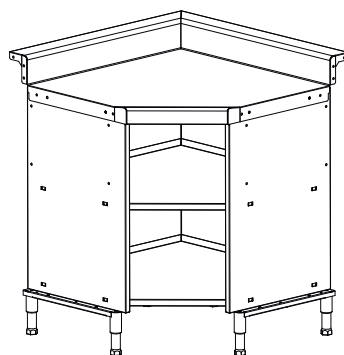

Corner Shelf Unit

MODEL	PRICE £	PRICE €	H	D
BZ80/080	£2096	€2411	950	560

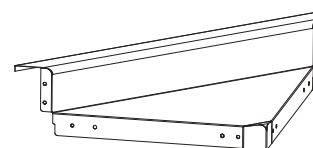

Corner Infill - 45° splash back

MODEL	PRICE £	PRICE €	D
BZ17/052	£476	€547	560

To link two runs of Bartender at the worktop level.

Bartender

Trims



Single Trim		
MODEL	PRICE £	PRICE €
BB71/001	£28	€33

BB71/001 Single Trims required at the end of the run or where there are bridge Units



Double Trim		
MODEL	PRICE £	PRICE €
BB71/002	£43	€49

BB71/002 Double Trims are required where connecting adjacent units.



Corner Trim		
MODEL	PRICE £	PRICE €
BB71/003	£67	€78

Legs & Bar Supports

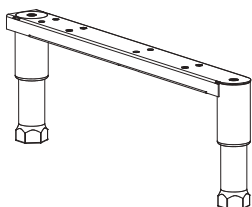

Leg Frames						
MODEL	PRICE £	PRICE €	H	W	D	
BB02/213	£79	€91	50	45	440	
BB02/212	£79	€91	100	45	440	
BB02/208	£79	€91	150	45	440	
BB02/308	£80	€93	200	45	440	

Units are supplied with one leg frame only, as adjacent units share one frame between them. Extra frames may be required:

- at the end of each straight run of Bartender
- where a bridge is introduced into a run

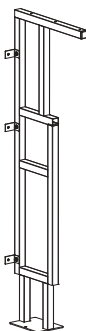

Bar Supports		
MODEL	PRICE £	PRICE €
BB70/001/SS	£328	€376
BB70/002/SS	£475	€546

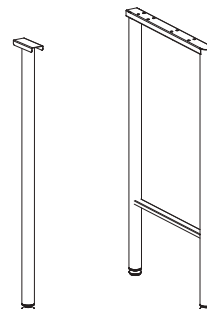

Pole Legs						
MODEL	PRICE £	PRICE €	TYPE	H	W	D
BB02/211	£92	€105	Single	850	45	100
BB02/210	£145	€167	Double	850	45	440

Supports infill or bridging section at end of run

Dècor Panel



Dècor Panel			
MODEL	PRICE £	PRICE €	D
BB56/001	£98	€113	475

Polished stainless steel dècor panels provide a clean and hygienic finish at the end of a run or on the sides of adjacent units to a bridge top covering the raw ends of a bar module.

Bridges

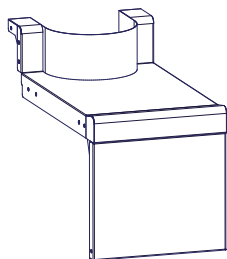

Python Bridge			
MODEL	PRICE £	PRICE €	W
BZ73/030	£471	€543	300

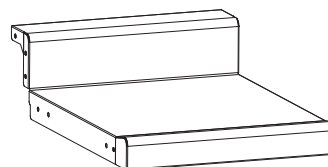

Plain Bridges			
MODEL	PRICE £	PRICE €	W
BZ09/0050	£421	€485	50
BZ09/0060	£421	€485	60
BZ09/0070	£421	€485	70
BZ09/0080	£421	€485	80
BZ09/0090	£421	€485	90
BZ09/010	£421	€485	100
BZ09/015	£421	€485	150
BZ09/020	£421	€485	200
BZ09/030	£433	€497	300
BZ09/035	£460	€529	350
BZ09/040	£460	€529	400
BZ09/0425	£489	€563	425
BZ09/045	£489	€563	450
BZ09/0475	£489	€563	475
BZ09/050	£489	€563	500
BZ09/0525	£489	€563	525
BZ09/055	£489	€563	550
BZ09/0575	£489	€563	575
BZ09/060	£489	€563	600
BZ09/0625	£501	€577	625
BZ09/065	£501	€577	650
BZ09/0675	£501	€577	675
BZ09/070	£501	€577	700
BZ09/0725	£515	€592	725
BZ09/075	£515	€593	750
BZ09/0775	£515	€593	775
BZ09/080	£515	€593	800
BZ09/0825	£526	€606	825
BZ09/085	£526	€606	850
BZ09/0875	£526	€606	875
BZ09/090	£526	€606	900
BZ09/0925	£539	€619	925
BZ09/095	£539	€619	950
BZ09/0975	£539	€619	975
BZ09/100	£539	€619	1000

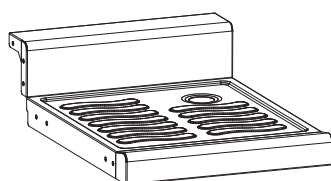

Drainer Bridges			
MODEL	PRICE £	PRICE €	W
BZ08/040	£552	€635	400
BZ08/060	£578	€665	600
BZ08/080	£602	€693	800
BZ08/100	£627	€722	1000

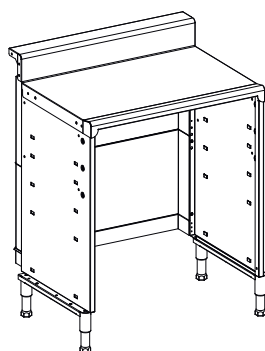

Ventus Unit			
MODEL	PRICE £	PRICE €	W
BZ15/101	£1004	€1156	700
BZ15/102	£1056	€1216	1000

Bartender

Infills

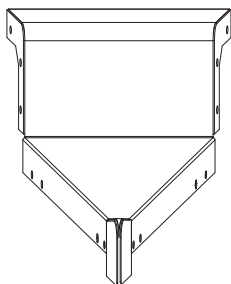

Internal Angle Infill			
MODEL	PRICE £	PRICE €	ANGLE
BB17/005 S	£474	€546	5
BB17/006 S	£474	€546	6
BB17/007 S	£474	€546	7
BB17/008 S	£474	€546	8
BB17/009 S	£474	€546	9
BB17/010 S	£474	€546	10
BB17/015 S	£489	€562	15
BB17/020 S	£489	€562	20
BB17/0225 S	£669	€770	22.5
BB17/030 S	£669	€770	30
BB17/040 S	£723	€832	40
BB17/045 S	£774	€891	45
BB17/050 S	£774	€891	50
BB17/060 S	£829	€954	60
BB17/070 S	£882	€1016	70
BB17/080 S	£935	€1076	80
BB17/BESPOKE	£POA	€POA	11-89

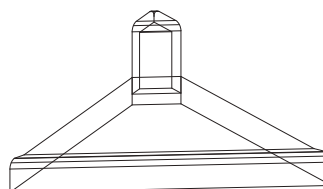

External Angle Infill			
MODEL	PRICE £	PRICE €	ANGLE
BB18/005 S	£432	€496	5
BB18/006 S	£432	€496	6
BB18/007 S	£432	€496	7
BB18/008 S	£432	€496	8
BB18/009 S	£432	€496	9
BB18/010 S	£432	€496	10
BB18/015 S	£460	€529	15
BB18/020 S	£460	€529	20
BB18/0225 S	£617	€709	22.5
BB18/030 S	£617	€709	30
BB18/040 S	£723	€832	40
BB18/045 S	£774	€881	45
BB18/050 S	£774	€881	50
BB18/060 S	£829	€954	60
BB18/070 S	£882	€1016	70
BB18/080 S	£935	€1076	80
BB18/090 S	£988	€1136	90
BB178/BESPOKE	£POA	€POA	11-89

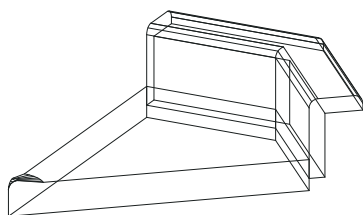

Internal Angle Infill Double Splashback			
MODEL	PRICE £	PRICE €	ANGLE
BB17/030 D	£669	€770	30
BB17/040 D	£723	€832	40
BB17/045 D	£566	€651	45
BB17/050 D	£774	€892	50
BB17/060 D	£830	€953	60
BB17/070 D	£882	€1016	70
BB17/080 D	£934	€1076	80
BB17/090 D	£1156	€1329	90

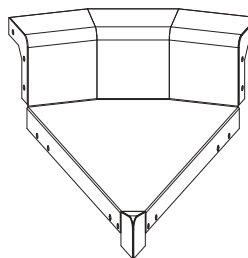

Internal Angle Infill Triple Splashback			
MODEL	PRICE £	PRICE €	ANGLE
BB17/030 T	£921	€1059	30
BB17/040 T	£921	€1059	40
BB17/045 T	£921	€1059	45
BB17/050 T	£921	€1059	50
BB17/060 T	£971	€1117	60
BB17/070 T	£1020	€1174	70
BB17/080 T	£1105	€1270	80
BB17/090 T	£1156	€1329	90

Ventus



With a wide range of options available, Ventus bottle coolers and glass frosters can be tailored to suit any bar environment.

Showcase drinks elegantly, while ensuring they are kept at the optimum serving temperature. We offer a wide variety of bottle coolers and glass frosters, with over 150 options to choose from, to ensure we have a design that complements every bar setting.

Each model has a Dynamic Air Distribution System, and EcoSmart controller, ensuring the most economical running. With a variety of space-saving sizes available, we're sure to have a solution perfect for any available space.

Ideally suited for...



Bars

Keep drinks at the perfect serving temperature to speed up service and generate customer satisfaction with ice cold drinks.



Clubs

Serve ice cold drinks with visual appeal with Ventus. With easy access, large storage capacities and rapid chill, keep the drinks flowing through your busiest periods.



Hotels

Attract customers in your hotel's bar with an elegant bottle cooler or glass froster. Show your drinks in their best light in a well-designed unit that enhances your offer.

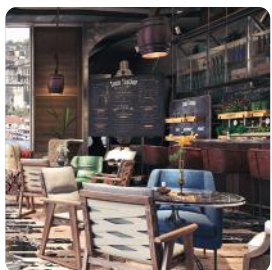

Cafes and coffee shops

Encourage customers to spend by tempting them with well-presented drinks. Showcase your offer and ensure great-tasting beverages with a Ventus unit.

With over 150 options available, tailor your Ventus bottle cooler to fit any setting.

Benefits at a glance

- Over 150 options to choose from
- Energy efficient EcoSmart controller
- Quick and easy access
- Variety of sizes to suit the space you have available
- Choice of exterior colours

Ventus Options

Ventus bottle coolers and glass frosters can be tailored to suit any bar environment.

Ventus V60								Ventus V90								Ventus V135			
V60 Standard - 900mm High	V60 Reduced Height - 850mm High	V60 Reduced Height - 800mm High	V60 Reduced Depth - 450mm Deep	V60 Full Front - 900mm High	V60 Full Front Reduced Height - 850mm High	V60 Full Front Reduced Height - 800mm High	V60 Full Front Reduced Depth - 450mm Deep	V90 Standard - 900mm High	V90 Reduced Height - 850mm High	V90 Reduced Height - 800mm High	V90 Reduced Depth - 450mm Deep	V90 Full Front - 900mm High	V90 Full Front Reduced Height - 850mm High	V90 Full Front Reduced Height - 800mm High	V90 Full Front Reduced Depth - 450mm Deep	V135 Standard - 900mm High	V135 Reduced Height - 800mm High	V135 Full Front - 900mm High	V135 Full Front Reduced Height - 800mm High

COLOUR

STAINLESS STEEL	•	•	•	•	•	•	•	•	•	•	•	•	•	•	•	•	•	•	•	•
BLACK	•	•	•	•	•	•	•	•	•	•	•	•	•	•	•	•	•	•	•	•

PLUG

UK 3 PIN PLUG	•	•	•	•	•	•	•	•	•	•	•	•	•	•	•	•	•	•	•	•
EU 2 PIN PLUG	○	○	○	○	○	○	○	○	○	○	○	○	○	○	○	○	○	○	○	○

DOOR TYPE

GLASS DOOR (STANDARD HANDLE ONLY)	•	•	•	•	•	•	•	•	•	•	•	•	•	•	•	•	•	•	•	•
SOLID DOOR (STANDARD HANDLE ONLY)	○	○	○	○	○	○	○	○	○	○	○	○	○	○	○	○	○	○	○	○
WOODEN CLADDED DOOR FRAME	N/A	N/A	N/A	N/A	○	○	○	○	N/A	N/A	N/A	N/A	○	○	○	○	N/A	N/A	○	○

DOOR HINGING

RIGHT HINGED	•	•	•	•	•	•	•	•	N/A	N/A	N/A	N/A	N/A	N/A	N/A	N/A	N/A	N/A	N/A	N/A
LEFT HINGED	○	○	○	○	○	○	○	○	N/A	N/A	N/A	N/A	N/A	N/A	N/A	N/A	N/A	N/A	N/A	N/A

HANDLE TYPE

STANDARD HANDLE	•	•	•	•	•	•	•	•	•	•	•	•	•	•	•	•	•	•	•	•
-----------------	---	---	---	---	---	---	---	---	---	---	---	---	---	---	---	---	---	---	---	---

SHELVING

CHROME WIRE SHELVING	•	•	•	•	•	•	•	•	•	•	•	•	•	•	•	•	•	•	•	•
PERFORATED SHELVING	○	○	○	○	○	○	○	○	○	○	○	○	○	○	○	○	○	○	○	○
WINE SHELVING	○	○	○	N/A	○	○	○	○	○	○	○	N/A	○	○	○	○	○	○	○	○

- Fitted as standard
- Available as an option
- N/A Not available for this model

Ventus Options

With over 150 options available, tailor your Ventus bottle cooler or glass froster to your requirements.

Door Styles



Standard



Full front



Solid

Shelving Type



Standard chrome wire



Chrome wine shelf



Perforated shelf

Ventus V60

Ventus V60 Standard - 900mm High

- Wide range of options available to customise your bottle cooler, ensure a perfect fit in any bar
- Elegant, flexible storage for up to 120 bottles
- Dynamic Air Distribution System coupled with efficient compressors and improved insulation ensures superior cooling times
- Electronic temperature control keeps drinks at the perfect serving temperature
- Energy efficient EcoSmart controller - at the touch of a button, put the bottle cooler into its most economical state until next required
- Sleek stainless steel interior and LED lighting to enhance display
- Single double-glazed lockable door for enhanced security
- UK 3 pin plug allows users to simply plug in and switch on



Ventus V60 Standard - 900mm High											
MODEL	PRICE £	PRICE €	DESCRIPTION	DOOR HINGING	H	W	D	POWER	GAS TYPE	CAPACITY	WT
F76/150	£2143	€2465	Glass Door Stainless Steel	Right	900	600	500	393W	R290	120 Bottles	65
F76/150/B	£2143	€2465	Glass Door Black Painted	Right	900	600	500	393W	R290	120 Bottles	65

V60 Standard 900mm High Factory Fit Options

MODEL	PRICE £	PRICE €	DESCRIPTION	
Door Type				
0*	VS430	£40	€46	Solid Door - Stainless Steel - Change from Standard Glass to Solid Door
0*	VS432	£40	€46	Solid Door - Black Painted - Change from Standard Glass to Solid Door
0*	VS406	£34	€40	Left Hinged Glass Door - Stainless Steel - Change from Standard Glass to Left Hinged Glass Door
0*	VS507	£34	€40	Left Hinged Glass Door - Black Painted - Change from Standard Glass to Left Hinged Glass Door
0*	VS454	£34	€40	Left Hinged Solid Door - Stainless Steel - Change from Standard Solid to Left Hinged Solid Door
0*	VS455	£34	€40	Left Hinged Solid Door - Black Painted - Change from Standard Solid to Left Hinged Solid Door
Shelving Type				
0*	VS399	£168	€194	Perforated Shelving - Change from Standard Wire Shelves to Perforated Shelves
0*	VS359	£43	€49	Wine Shelving - Change from Standard Wire Shelves to Wine Shelves
Plug Type				
0*	VS401	£0	€0	EU 2-Pin Plug - Change from UK to EU Plug
De-gassed				
0*	VS1017	£111	€128	De-gassed Unit (Only Required to Make Suitable for Air Freight)

0* Factory fitted option please request at point of ordering

Accessories

MODEL	PRICE £	PRICE €	DESCRIPTION	
A	A12/100	£140	€161	Chrome Wine Shelf
A	A12/091/Z1	£70	€81	Chrome Wire Shelf
A	S76/048	£43.15	€49.70	Perforated Shelf

Ventus V60 Reduced Height - 850mm High

- Reduced 850mm height
- Wide range of options available to customise your bottle cooler, ensure a perfect fit in any bar
- Elegant, flexible storage for up to 78 bottles
- Dynamic Air Distribution System coupled with efficient compressors and improved insulation ensures superior cooling times
- Electronic temperature control keeps drinks at the perfect serving temperature
- Energy efficient EcoSmart controller - at the touch of a button, put the bottle cooler into its most economical state until next required
- Sleek stainless steel interior and LED lighting to enhance display
- Single double-glazed lockable door for enhanced security
- UK 3 pin plug allows users to simply plug in and switch on



Ventus V60 Reduced Height - 850mm High											
MODEL	PRICE £	PRICE €	DESCRIPTION	DOOR HINGING	H	W	D	POWER	GAS TYPE	CAPACITY	WT
F76/151	£2143	€2465	Glass Door Stainless Steel	Right	850	600	500	393W	R290	78 Bottles	64
F76/151/B	£2143	€2465	Glass Door Black Painted	Right	850	600	500	393W	R290	78 Bottles	64

V60 Standard 850mm High Factory Fit Options

MODEL	PRICE £	PRICE €	DESCRIPTION	
Door Type				
0*	VS431	£40	€46	Solid Door - Stainless Steel - Change from Standard Glass to Solid Door
0*	VS433	£40	€46	Solid Door - Black Painted - Change from Standard Glass to Solid Door
0*	VS407	£34	€40	Left Hinged Glass Door - Stainless Steel - Change from Standard Glass to Left Hinged Glass Door
0*	VS508	£34	€40	Left Hinged Glass Door - Black Painted - Change from Standard Glass to Left Hinged Glass Door
0*	VS545	£34	€40	Left Hinged Solid Door - Stainless Steel - Change from Standard Solid to Left Hinged Solid Door
0*	VS627	£34	€40	Left Hinged Solid Door - Black Painted - Change from Standard Solid to Left Hinged Solid Door
Shelving Type				
0*	VS399	£168	€194	Perforated Shelving - Change from Standard Wire Shelves to Perforated Shelves
0*	VS359	£43	€49	Wine Shelving - Change from Standard Wire Shelves to Wine Shelves
Plug Type				
0*	VS401	£0	€0	EU 2-Pin Plug - Change from UK to EU Plug
De-gassed				
0*	VS1017	£111	€128	De-gassed Unit (Only Required to Make Suitable for Air Freighting)

0* Factory fitted option please request at point of ordering

Accessories

MODEL	PRICE £	PRICE €	DESCRIPTION	
A	A12/100	£140	€161	Chrome Wine Shelf
A	A12/091/Z1	£70	€81	Chrome Wire Shelf
A	S76/048	£43.15	€49.70	Perforated Shelf

Ventus V60

Ventus V60 Reduced Height - 800mm High

- Reduced 800mm height
- Wide range of options available to customise your bottle cooler, ensure a perfect fit in any bar
- Elegant, flexible storage for up to 78 bottles
- Dynamic Air Distribution System coupled with efficient compressors and improved insulation ensures superior cooling times
- Electronic temperature control keeps drinks at the perfect serving temperature
- Energy efficient EcoSmart controller - at the touch of a button, put the bottle cooler into its most economical state until next required
- Sleek stainless steel interior and LED lighting to enhance display
- Single double-glazed lockable door for enhanced security
- UK 3 pin plug allows users to simply plug in and switch on



Ventus V60 Reduced Height - 800mm High											
MODEL	PRICE £	PRICE €	DESCRIPTION	DOOR HINGING	H	W	D	POWER	GAS TYPE	CAPACITY	WT
F76/152	£2143	€2465	Glass Door Stainless Steel	Right	800	600	500	393W	R290	78 Bottles	62
F76/152/B	£2143	€2465	Glass Door Black Painted	Right	800	600	500	393W	R290	78 Bottles	62

V60 Standard 800mm High Factory Fit Options

MODEL	PRICE £	PRICE €	DESCRIPTION
Door Type			
0* VS409	£40	€46	Solid Door - Stainless Steel - Change from Standard Glass to Solid Door
0* VS414	£40	€46	Solid Door - Black Painted - Change from Standard Glass to Solid Door
0* VS408	£34	€40	Left Hinged Glass Door - Stainless Steel - Change from Standard Glass to Left Hinged Glass Door
0* VS509	£34	€40	Left Hinged Glass Door - Black Painted - Change from Standard Glass to Left Hinged Glass Door
0* VS618	£34	€40	Left Hinged Solid Door - Stainless Steel - Change from Standard Solid to Left Hinged Solid Door
0* VS652	£34	€40	Left Hinged Solid Door - Black Painted - Change from Standard Solid to Left Hinged Solid Door
Shelving Type			
0* VS399	£168	€194	Perforated Shelving - Change from Standard Wire Shelves to Perforated Shelves
0* VS359	£43	€49	Wine Shelving - Change from Standard Wire Shelves to Wine Shelves
Plug Type			
0* VS401	£0	€0	EU 2-Pin Plug - Change from UK to EU Plug
De-gassed			
0* VS1017	£111	€128	De-gassed Unit (Only Required to Make Suitable for Air Freighting)

0* Factory fitted option please request at point of ordering

Accessories

MODEL	PRICE £	PRICE €	DESCRIPTION
A A12/100	£140	€161	Chrome Wine Shelf
A A12/091/Z1	£70	€81	Chrome Wire Shelf
A S76/048	£43.15	€49.70	Perforated Shelf

Ventus V60

Ventus V60 Reduced Depth - 450mm Deep

- Reduced 450mm depth
- Wide range of options available to customise your bottle cooler, ensure a perfect fit in any bar
- Elegant, flexible storage for up to 96 bottles
- Dynamic Air Distribution System coupled with efficient compressors and improved insulation ensures superior cooling times
- Electronic temperature control keeps drinks at the perfect serving temperature
- Energy efficient EcoSmart controller - at the touch of a button, put the bottle cooler into its most economical state until next required
- Sleek stainless steel interior and LED lighting to enhance display
- Single double-glazed lockable door for enhanced security
- UK 3 pin plug allows users to simply plug in and switch on



Ventus V60 Reduced Depth - 900mm High											
MODEL	PRICE £	PRICE €	DESCRIPTION	DOOR HINGING	H	W	D	POWER	GAS TYPE	CAPACITY	WT
F76/153	£2143	€2465	Glass Door Stainless Steel	Right	900	600	450	393W	R290	96 Bottles	64
F76/153/B	£2143	€2465	Glass Door Black Painted	Right	900	600	450	393W	R290	96 Bottles	64

V60 Standard 900mm High Factory Fit Options

MODEL	PRICE £	PRICE €	DESCRIPTION
Door Type			
0* VS430	£40	€46	Solid Door - Stainless Steel - Change from Standard Glass to Solid Door
0* VS432	£40	€46	Solid Door - Black Painted - Change from Standard Glass to Solid Door
0* VS406	£34	€40	Left Hinged Glass Door - Stainless Steel - Change from Standard Glass to Left Hinged Glass Door
0* VS507	£34	€40	Left Hinged Glass Door - Black Painted - Change from Standard Glass to Left Hinged Glass Door
0* VS454	£34	€40	Left Hinged Solid Door - Stainless Steel - Change from Standard Solid to Left Hinged Solid Door
0* VS455	£34	€40	Left Hinged Solid Door - Black Painted - Change from Standard Solid to Left Hinged Solid Door
Shelving Type			
0* VS402	£168	€194	Perforated Shelving - Change from Standard Wire Shelves to Perforated Shelves
Plug Type			
0* VS401	£0	€0	EU 2-Pin Plug - Change from UK to EU Plug
De-gassed			
0* VS1017	£111	€128	De-gassed Unit (Only Required to Make Suitable for Air Freighting)

0* Factory fitted option please request at point of ordering

Ventus V60

Ventus V60 Full Front - 900mm High

- Full front door for seamless integration
- Wide range of options available to customise your bottle cooler, ensure a perfect fit in any bar
- Elegant, flexible storage for up to 120 bottles
- Dynamic Air Distribution System coupled with efficient compressors and improved insulation ensures superior cooling times
- Electronic temperature control keeps drinks at the perfect serving temperature
- Energy efficient EcoSmart controller - at the touch of a button, put the bottle cooler into its most economical state until next required
- Sleek stainless steel interior and LED lighting to enhance display
- Double-glazed door for enhanced insulation
- UK 3 pin plug allows users to simply plug in and switch on



Ventus V60 Full Front - 900mm High											
MODEL	PRICE £	PRICE €	DESCRIPTION	DOOR HINGING	H	W	D	POWER	GAS TYPE	CAPACITY	WT
F76/170	£2143	€2465	Glass Door Stainless Steel	Right	900	600	500	393W	R290	120 Bottles	65
F76/170/B	£2143	€2465	Glass Door Black Painted	Right	900	600	500	393W	R290	120 Bottles	65

V60 Full Front Glass 900mm High Factory Fit Options

MODEL	PRICE £	PRICE €	DESCRIPTION
Door Type			
0* VS726	£40	€46	Solid Door - Stainless Steel - Change from Full Front Glass to Full Front Solid Door
0* VS738	£40	€46	Solid Door - Black Painted - Change from Full Front Glass to Full Front Solid Door
0* VS709	£40	€46	Left Hinged Glass Door - Stainless Steel - Change from Right Hinged to Left Hinged Glass Door
0* VS712	£40	€46	Left Hinged Glass Door - Black Painted - Change from Right Hinged to Left Hinged Glass Door
0* VS729	£40	€46	Left Hinged Solid Door - Stainless Steel - Change from Right Hinged to Left Hinged Solid Door
0* VS741	£40	€46	Left Hinged Solid Door - Black Painted - Change from Right Hinged to Left Hinged Solid Door
0* VS1009	£29	€35	Full Front Cladded Door - Stainless Steel - Change from Glass Door to Own Cladding - Customer Supplied Wood Panel
0* VS1026	£36	€42	Full Front Cladded Door - Black Painted - Change from Glass Door to Own Cladding - Customer Supplied Wood Panel
0* VS708	£83	€96	Left Hand Hinge Kit for Full Front Cladded Doors - Stainless Steel - Add to Full Front Cladded Models to Convert to Left Hand Hinge
0* VS708B	£83	€96	Left Hand Hinge Kit for Full Front Cladded Doors - Black Painted - Add to Full Front Cladded Models to Convert to Left Hand Hinge
Shelving Type			
0* VS399	£168	€194	Perforated Shelving - Change from Standard Wire Shelves to Perforated Shelves
0* VS359	£43	€49	Wine Shelving - Change from Standard Wire Shelves to Wine Shelves
Plug Type			
0* VS401	£0	€0	EU 2-Pin Plug - Change from UK to EU Plug
De-gassed			
0* VS1017	£111	€128	De-gassed Unit (Only Required to Make Suitable for Air Freighting)

0* Factory fitted option please request at point of ordering

Accessories

MODEL	PRICE £	PRICE €	DESCRIPTION
A A12/100	£140	€161	Chrome Wine Shelf
A A12/091/Z1	£70	€81	Chrome Wire Shelf
A S76/048	£43.15	€49.70	Perforated Shelf

2 YEAR UK parts and labour warranty | Export parts warranty
on all IMC products

Ventus V60 Full Front - 850mm High

- Full front door for seamless integration
- Reduced 850mm height
- Wide range of options available to customise your bottle cooler, ensure a perfect fit in any bar
- Elegant, flexible storage for up to 78 bottles
- Dynamic Air Distribution System coupled with efficient compressors and improved insulation ensures superior cooling times
- Electronic temperature control keeps drinks at the perfect serving temperature
- Energy efficient EcoSmart controller - at the touch of a button, put the bottle cooler into its most economical state until next required
- Sleek stainless steel interior and LED lighting to enhance display
- Double-glazed door for enhanced insulation
- UK 3 pin plug allows users to simply plug in and switch on



Ventus V60 Full Front - 850mm High											
MODEL	PRICE £	PRICE €	DESCRIPTION	DOOR HINGING	H	W	D	POWER	GAS TYPE	CAPACITY	WT
F76/171	£2143	€2465	Glass Door Stainless Steel	Right	850	600	500	393W	R290	78 Bottles	64
F76/171/B	£2143	€2465	Glass Door Black Painted	Right	850	600	500	393W	R290	78 Bottles	64

V60 Full Front Glass 850mm High Factory Fit Options

MODEL	PRICE £	PRICE €	DESCRIPTION
Door Type			
0* VS727	£40	€46	Solid Door - Stainless Steel - Change from Full Front Glass to Full Front Solid Door
0* VS739	£40	€46	Solid Door - Black Painted - Change from Full Front Glass to Full Front Solid Door
0* VS710	£40	€46	Left Hinged Glass Door - Stainless Steel - Change from Right Hinged to Left Hinged Glass Door
0* VS713	£40	€46	Left Hinged Glass Door - Black Painted - Change from Right Hinged to Left Hinged Glass Door
0* VS730	£40	€46	Left Hinged Solid Door - Stainless Steel - Change from Right Hinged to Left Hinged Solid Door
0* VS742	£40	€46	Left Hinged Solid Door - Black Painted - Change from Right Hinged to Left Hinged Solid Door
0* VS1010	£29	€35	Full Front Cladded Door - Stainless Steel - Change from Glass Door to Own Cladding - Customer Supplied Wood Panel
0* VS1027	£36	€42	Full Front Cladded Door - Black Painted - Change from Glass Door to Own Cladding - Customer Supplied Wood Panel
0* VS708	£83	€96	Left Hand Hinge Kit for Full Front Cladded Doors - Stainless Steel - Add to Full Front Cladded Models to Convert to Left Hand Hinge
0* VS708B	£83	€96	Left Hand Hinge Kit for Full Front Cladded Doors - Black Painted - Add to Full Front Cladded Models to Convert to Left Hand Hinge
Shelving Type			
0* VS399	£168	€194	Perforated Shelving - Change from Standard Wire Shelves to Perforated Shelves
0* VS359	£43	€49	Wine Shelving - Change from Standard Wire Shelves to Wine Shelves
Plug Type			
0* VS401	£0	€0	EU 2-Pin Plug - Change from UK to EU Plug
De-gassed			
0* VS1017	£111	€128	De-gassed Unit (Only Required to Make Suitable for Air Freighting)

0* Factory fitted option please request at point of ordering

Accessories

MODEL	PRICE £	PRICE €	DESCRIPTION
A A12/100	£140	€161	Chrome Wine Shelf
A A12/091/Z1	£70	€81	Chrome Wire Shelf
A S76/048	£43.15	€49.70	Perforated Shelf

2
YEAR

UK parts
and labour
warranty

Export
parts
warranty

on all IMC products

Ventus V60

Ventus V60 Full Front - 800mm High

- Full front door for seamless integration
- Reduced 800mm height
- Wide range of options available to customise your bottle cooler, ensure a perfect fit in any bar
- Elegant, flexible storage for up to 78 bottles
- Dynamic Air Distribution System coupled with efficient compressors and improved insulation ensures superior cooling times
- Electronic temperature control keeps drinks at the perfect serving temperature
- Energy efficient EcoSmart controller - at the touch of a button, put the bottle cooler into its most economical state until next required
- Sleek stainless steel interior and LED lighting to enhance display
- Double-glazed door for enhanced insulation
- UK 3 pin plug allows users to simply plug in and switch on



Ventus V60 Full Front Glass - 800mm High											
MODEL	PRICE £	PRICE €	DESCRIPTION	DOOR HINGING	H	W	D	POWER	GAS TYPE	CAPACITY	WT
F76/172	£2143	€2465	Glass Door Stainless Steel	Right	800	600	500	393W	R290	78 Bottles	62
F76/172/B	£2143	€2465	Glass Door Black Painted	Right	800	600	500	393W	R290	78 Bottles	62

V60 Full Front Glass 800mm High Factory Fit Options

MODEL	PRICE £	PRICE €	DESCRIPTION
Door Type			
0* VS728	£40	€46	Solid Door - Stainless Steel - Change from Full Front Glass to Full Front Solid Door
0* VS740	£40	€46	Solid Door - Black Painted - Change from Full Front Glass to Full Front Solid Door
0* VS711	£40	€46	Left Hinged Glass Door - Stainless Steel - Change from Right Hinged to Left Hinged Glass Door
0* VS714	£40	€46	Left Hinged Glass Door - Black Painted - Change from Right Hinged to Left Hinged Glass Door
0* VS731	£40	€46	Left Hinged Solid Door - Stainless Steel - Change from Right Hinged to Left Hinged Solid Door
0* VS743	£40	€46	Left Hinged Solid Door - Black Painted - Change from Right Hinged to Left Hinged Solid Door
0* VS1011	£29	€35	Full Front Cladded Door - Stainless Steel - Change from Glass Door to Own Cladding - Customer Supplied Wood Panel
0* VS1028	£36	€42	Full Front Cladded Door - Black Painted - Change from Glass Door to Own Cladding - Customer Supplied Wood Panel
0* VS708	£83	€96	Left Hand Hinge Kit for Full Front Cladded Doors - Stainless Steel - Add to Full Front Cladded Models to Convert to Left Hand Hinge
0* VS708B	£83	€96	Left Hand Hinge Kit for Full Front Cladded Doors - Black Painted - Add to Full Front Cladded Models to Convert to Left Hand Hinge
Shelving Type			
0* VS399	£168	€194	Perforated Shelving - Change from Standard Wire Shelves to Perforated Shelves
0* VS359	£43	€49	Wine Shelving - Change from Standard Wire Shelves to Wine Shelves
Plug Type			
0* VS401	£0	€0	EU 2-Pin Plug - Change from UK to EU Plug
De-gassed			
0* VS1017	£111	€128	De-gassed Unit (Only Required to Make Suitable for Air Freighting)

0* Factory fitted option please request at point of ordering

Accessories

MODEL	PRICE £	PRICE €	DESCRIPTION
A A12/100	£140	€161	Chrome Wine Shelf
A A12/091/Z1	£70	€81	Chrome Wire Shelf
A S76/048	£43.15	€49.70	Perforated Shelf

2

UK parts
and labour
warranty

Export
parts
warranty

on all IMC products

Ventus V60

Ventus V60 Full Front Reduced Depth - 450mm Deep

- Full front door for seamless integration
- Reduced 450mm depth
- Wide range of options available to customise your bottle cooler, ensure a perfect fit in any bar
- Elegant, flexible storage for up to 96 bottles
- Dynamic Air Distribution System coupled with efficient compressors and improved insulation ensures superior cooling times
- Electronic temperature control keeps drinks at the perfect serving temperature
- Energy efficient EcoSmart controller - at the touch of a button, put the bottle cooler into its most economical state until next required
- Sleek stainless steel interior and LED lighting to enhance display
- Double-glazed door for enhanced insulation
- UK 3 pin plug allows users to simply plug in and switch on



Ventus V60 Reduced Depth - 900mm High											
MODEL	PRICE £	PRICE €	DESCRIPTION	DOOR HINGING	H	W	D	POWER	GAS TYPE	CAPACITY	WT
F76/173	£2143	€2465	Glass Door Stainless Steel	Right	900	600	450	393W	R290	96 Bottles	64
F76/173/B	£2143	€2465	Glass Door Black Painted	Right	900	600	450	393W	R290	96 Bottles	64

V60 Standard 900mm High Factory Fit Options

MODEL	PRICE £	PRICE €	DESCRIPTION	
Door Type				
0*	VS430	£40	€46	Solid Door - Stainless Steel - Change from Standard Glass to Solid Door
0*	VS432	£40	€46	Solid Door - Black Painted - Change from Standard Glass to Solid Door
0*	VS709	£40	€46	Left Hinged Glass Door - Stainless Steel - Change from Standard Glass to Left Hinged Glass Door
0*	VS712	£40	€46	Left Hinged Glass Door - Black Painted - Change from Standard Glass to Left Hinged Glass Door
0*	VS729	£40	€46	Left Hinged Solid Door - Stainless Steel - Change from Standard Solid to Left Hinged Solid Door
0*	VS741	£40	€46	Left Hinged Solid Door - Black Painted - Change from Standard Solid to Left Hinged Solid Door
Shelving Type				
0*	VS402	£168	€194	Perforated Shelving - Change from Standard Wire Shelves to Perforated Shelves
Plug Type				
0*	VS401	£0	€0	EU 2-Pin Plug - Change from UK to EU Plug
De-gassed				
0*	VS1017	£111	€128	De-gassed Unit (Only Required to Make Suitable for Air Freighting)

0* Factory fitted option please request at point of ordering

2 YEAR
UK parts and labour warranty | Export parts warranty
on all IMC products

Ventus V90

Ventus V90 Standard - 900mm High

- Wide range of options available to customise your bottle cooler, ensure a perfect fit in any bar
- Elegant, flexible storage for up to 195 bottles
- Dynamic Air Distribution System coupled with efficient compressors and improved insulation ensures superior cooling times
- Electronic temperature control keeps drinks at the perfect serving temperature
- Energy efficient EcoSmart controller - at the touch of a button, put the bottle cooler into its most economical state until next required
- Sleek stainless steel interior and LED lighting to enhance display
- Twin double-glazed lockable doors for enhanced security
- UK 3 pin plug allows users to simply plug in and switch on



Ventus V90 Standard - 900mm High											
MODEL	PRICE £	PRICE €	DESCRIPTION	DOOR HINGING	H	W	D	POWER	GAS TYPE	CAPACITY	WT
F76/250	£3179	€3656	Glass Door Stainless Steel	Left; Right	900	900	500	410W	R290	195 Bottles	86
F76/250/B	£3179	€3656	Glass Door Black Painted	Left; Right	900	900	500	410W	R290	195 Bottles	86

V90 Standard 900mm High Factory Fit Options

MODEL	PRICE £	PRICE €	DESCRIPTION
Door Type			
0* VS428	£65	€75	Solid Door - Stainless Steel - Change from Standard Glass to Solid Door
0* VS419	£65	€75	Solid Door - Black Painted - Change from Standard Glass to Solid Door
Shelving Type			
0* VS400	£218	€251	Perforated Shelving - Change from Standard Wire Shelves to Perforated Shelves
0* VS360	£43	€49	Wine Shelving - Change from Standard Wire Shelves to Wine Shelves
Plug Type			
0* VS401	£0	€0	EU 2-Pin Plug - Change from UK to EU Plug
De-gassed			
0* VS1017	£111	€128	De-gassed Unit (Only Required to Make Suitable for Air Freighting)

0* Factory fitted option please request at point of ordering

Accessories

MODEL	PRICE £	PRICE €	DESCRIPTION
A A12/101	£108	€124	Chrome Wine Shelf
A A12/092/Z1	£131	€151	Chrome Wire Shelf

Ventus V90

Ventus V90 Reduced Height - 850mm High

- Reduced 850mm height
- Wide range of options available to customise your bottle cooler, ensure a perfect fit in any bar
- Elegant, flexible storage for up to 117 bottles
- Dynamic Air Distribution System coupled with efficient compressors and improved insulation ensures superior cooling times
- Electronic temperature control keeps drinks at the perfect serving temperature
- Energy efficient EcoSmart controller - at the touch of a button, put the bottle cooler into its most economical state until next required
- Sleek stainless steel interior and LED lighting to enhance display
- Twin double-glazed lockable doors for enhanced security
- UK 3 pin plug allows users to simply plug in and switch on



Ventus V90 Reduced Height - 850mm High											
MODEL	PRICE £	PRICE €	DESCRIPTION	DOOR HINGING	H	W	D	POWER	GAS TYPE	CAPACITY	WT
F76/251	£3179	€3656	Glass Door Stainless Steel	Left; Right	850	900	500	410W	R290	117 Bottles	85
F76/251/B	£3179	€3656	Glass Door Black Painted	Left; Right	850	900	500	410W	R290	117 Bottles	85

V90 Reduced Height 850mm High Factory Fit Options

MODEL	PRICE £	PRICE €	DESCRIPTION
Door Type			
0* VS429	£65	€75	Solid Door - Stainless Steel - Change from Standard Glass to Solid Door
0* VS422	£65	€75	Solid Door - Black Painted - Change from Standard Glass to Solid Door
Shelving Type			
0* VS400	£218	€251	Perforated Shelving - Change from Standard Wire Shelves to Perforated Shelves
0* VS360	£43	€49	Wine Shelving - Change from Standard Wire Shelves to Wine Shelves
Plug Type			
0* VS401	£0	€0	EU 2-Pin Plug - Change from UK to EU Plug
De-gassed			
0* VS1017	£111	€128	De-gassed Unit (Only Required to Make Suitable for Air Freighting)

0* Factory fitted option please request at point of ordering

Accessories

MODEL	PRICE £	PRICE €	DESCRIPTION
A A12/101	£108	€124	Chrome Wine Shelf
A A12/092/Z1	£131	€151	Chrome Wire Shelf

2 YEAR
UK parts and labour warranty | Export parts warranty
on all IMC products

Ventus V90

Ventus V90 Reduced Height - 800mm High

- Reduced 800mm height
- Wide range of options available to customise your bottle cooler, ensure a perfect fit in any bar
- Elegant, flexible storage for up to 117 bottles
- Dynamic Air Distribution System coupled with efficient compressors and improved insulation ensures superior cooling times
- Electronic temperature control keeps drinks at the perfect serving temperature
- Energy efficient EcoSmart controller - at the touch of a button, put the bottle cooler into its most economical state until next required
- Sleek stainless steel interior and LED lighting to enhance display
- Twin double-glazed lockable doors for enhanced security
- UK 3 pin plug allows users to simply plug in and switch on



Ventus V90 Reduced Height - 800mm High											
MODEL	PRICE £	PRICE €	DESCRIPTION	DOOR HINGING	H	W	D	POWER	GAS TYPE	CAPACITY	WT
F76/252	£3179	€3656	Glass Door Stainless Steel	Left; Right	800	900	500	410W	R290	117 Bottles	82
F76/252/B	£3179	€3656	Glass Door Black Painted	Left; Right	800	900	500	410W	R290	117 Bottles	82

V90 Reduced Height 800mm High Factory Fit Options

MODEL	PRICE £	PRICE €	DESCRIPTION
Door Type			
0* VS410	£65	€75	Solid Door - Stainless Steel - Change from Standard Glass to Solid Door
0* VS425	£65	€75	Solid Door - Black Painted - Change from Standard Glass to Solid Door
Shelving Type			
0* VS400	£218	€251	Perforated Shelving - Change from Standard Wire Shelves to Perforated Shelves
0* VS360	£43	€49	Wine Shelving - Change from Standard Wire Shelves to Wine Shelves
Plug Type			
0* VS401	£0	€0	EU 2-Pin Plug - Change from UK to EU Plug
De-gassed			
0* VS1017	£111	€128	De-gassed Unit (Only Required to Make Suitable for Air Freighting)

0* Factory fitted option please request at point of ordering

Accessories

MODEL	PRICE £	PRICE €	DESCRIPTION
A A12/101	£108	€124	Chrome Wine Shelf
A A12/092/Z1	£131	€151	Chrome Wire Shelf

2
YEAR

UK parts
and labour
warranty

Export
parts
warranty

on all IMC products

Ventus V90

Ventus V90 Reduced Depth - 450mm Deep

- Reduced 450mm depth
- Wide range of options available to customise your bottle cooler, ensure a perfect fit in any bar
- Elegant, flexible storage for up to 156 bottles
- Dynamic Air Distribution System coupled with efficient compressors and improved insulation ensures superior cooling times
- Electronic temperature control keeps drinks at the perfect serving temperature
- Energy efficient EcoSmart controller - at the touch of a button, put the bottle cooler into its most economical state until next required
- Sleek stainless steel interior and LED lighting to enhance display
- Twin double-glazed lockable doors for enhanced security
- UK 3 pin plug allows users to simply plug in and switch on



Ventus V90 Reduced Depth - 900mm High											
MODEL	PRICE £	PRICE €	DESCRIPTION	DOOR HINGING	H	W	D	POWER	GAS TYPE	CAPACITY	WT
F76/253	£3179	€3656	Glass Door Stainless Steel	Left; Right	900	900	450	410W	R290	156 Bottles	84
F76/253/B	£3179	€3656	Glass Door Black Painted	Left; Right	900	900	450	410W	R290	156 Bottles	84

V90 Reduced Depth 450mm Deep Factory Fit Options

MODEL	PRICE £	PRICE €	DESCRIPTION
Door Type			
0* VS428	£65	€75	Solid Door - Stainless Steel - Change from Standard Glass to Solid Door
0* VS419	£65	€75	Solid Door - Black Painted - Change from Standard Glass to Solid Door
Shelving Type			
Plug Type			
0* VS401	£0	€0	EU 2-Pin Plug - Change from UK to EU Plug
De-gassed			
0* VS1017	£111	€128	De-gassed Unit (Only Required to Make Suitable for Air Freighting)

0* Factory fitted option please request at point of ordering

2
YEAR

UK parts
and labour
warranty

Export
parts
warranty

on all IMC products

Ventus V90

Ventus V90 Full Front - 900mm High

- Full front door for seamless integration
- Wide range of options available to customise your bottle cooler, ensure a perfect fit in any bar
- Elegant, flexible storage for up to 195 bottles
- Dynamic Air Distribution System coupled with efficient compressors and improved insulation ensures superior cooling times
- Electronic temperature control keeps drinks at the perfect serving temperature
- Energy efficient EcoSmart controller - at the touch of a button, put the bottle cooler into its most economical state until next required
- Sleek stainless steel interior and LED lighting to enhance display
- Double-glazed doors for enhanced insulation
- UK 3 pin plug allows users to simply plug in and switch on



Ventus V90 Full Front - 900mm High											
MODEL	PRICE £	PRICE €	DESCRIPTION	DOOR HINGING	H	W	D	POWER	GAS TYPE	CAPACITY	WT
F76/270	£3179	€3656	Glass Door Stainless Steel	Left; Right	900	900	500	393W	R290	195 Bottles	86
F76/270/B	£3179	€3656	Glass Door Black Painted	Left; Right	900	900	500	393W	R290	195 Bottles	86

V90 Full Front Glass 900mm High Factory Fit Options

MODEL	PRICE £	PRICE €	DESCRIPTION
Door Type			
0* VS732	£65	€75	Solid Door - Stainless Steel - Change from Full Front Glass to Full Front Solid Door
0* VS744	£65	€75	Solid Door - Black Painted - Change from Full Front Glass to Full Front Solid Door
0* VS1012	£55	€64	Full Front Cladded Door - Stainless Steel - Change from Glass Door to Own Cladding - Customer Supplied Wood Panel
0* VS1029	£69	€80	Full Front Cladded Door - Black Painted - Change from Glass Door to Own Cladding - Customer Supplied Wood Panel
Shelving Type			
0* VS400	£218	€251	Perforated Shelving - Change from Standard Wire Shelves to Perforated Shelves
0* VS360	£43	€49	Wine Shelving - Change from Standard Wire Shelves to Wine Shelves
Plug Type			
0* VS401	£0	€0	EU 2-Pin Plug - Change from UK to EU Plug
De-gassed			
0* VS1017	£111	€128	De-gassed Unit (Only Required to Make Suitable for Air Freighting)

0* Factory fitted option please request at point of ordering

Accessories

MODEL	PRICE £	PRICE €	DESCRIPTION
A A12/101	£108	€124	Chrome Wine Shelf
A A12/092/Z1	£131	€151	Chrome Wire Shelf

2

UK parts
and labour
warranty

Export
parts
warranty

on all IMC products

Ventus V90

Ventus V90 Full Front - 850mm High

- Full front door for seamless integration
- Reduced 850mm height
- Wide range of options available to customise your bottle cooler, ensure a perfect fit in any bar
- Elegant, flexible storage for up to 117 bottles
- Dynamic Air Distribution System coupled with efficient compressors and improved insulation ensures superior cooling times
- Electronic temperature control keeps drinks at the perfect serving temperature
- Energy efficient EcoSmart controller - at the touch of a button, put the bottle cooler into its most economical state until next required
- Sleek stainless steel interior and LED lighting to enhance display
- Double-glazed doors for enhanced insulation
- UK 3 pin plug allows users to simply plug in and switch on



Ventus V90 Full Front - 850mm High											
MODEL	PRICE £	PRICE €	DESCRIPTION	DOOR HINGING	H	W	D	POWER	GAS TYPE	CAPACITY	WT
F76/271	£3179	€3656	Glass Door Stainless Steel	Left, Right	850	900	500	393W	R290	117 Bottles	85
F76/271/B	£3179	€3656	Glass Door Black Painted	Left, Right	850	900	500	393W	R290	117 Bottles	85

V90 Full Front Glass 850mm High Factory Fit Options

MODEL	PRICE £	PRICE €	DESCRIPTION
Door Type			
0* VS733	£65	€80	Solid Door - Stainless Steel - Change from Full Front Glass to Full Front Solid Door
0* VS745	£65	€80	Solid Door - Black Painted - Change from Full Front Glass to Full Front Solid Door
0* VS1013	£55	€64	Full Front Cladded Door - Stainless Steel - Change from Glass Door to Own Cladding - Customer Supplied Wood Panel
0* VS1030	£69	€84	Full Front Cladded Door - Black Painted - Change from Glass Door to Own Cladding - Customer Supplied Wood Panel
Shelving Type			
0* VS400	£218	€251	Perforated Shelving - Change from Standard Wire Shelves to Perforated Shelves
0* VS360	£43	€49	Wine Shelving - Change from Standard Wire Shelves to Wine Shelves
Plug Type			
0* VS401	£0	€0	EU 2-Pin Plug - Change from UK to EU Plug
De-gassed			
0* VS1017	£111	€128	De-gassed Unit (Only Required to Make Suitable for Air Freighting)

0* Factory fitted option please request at point of ordering

Accessories

MODEL	PRICE £	PRICE €	DESCRIPTION
A A12/101	£108	€124	Chrome Wine Shelf
A A12/092/Z1	£131	€151	Chrome Wire Shelf

2
YEAR

UK parts
and labour
warranty

Export
parts
warranty

on all IMC products

Ventus V90

Ventus V90 Full Front - 800mm High

- Full front door for seamless integration
- Reduced 800mm height
- Wide range of options available to customise your bottle cooler, ensure a perfect fit in any bar
- Elegant, flexible storage for up to 117 bottles
- Dynamic Air Distribution System coupled with efficient compressors and improved insulation ensures superior cooling times
- Electronic temperature control keeps drinks at the perfect serving temperature
- Energy efficient EcoSmart controller - at the touch of a button, put the bottle cooler into its most economical state until next required
- Sleek stainless steel interior and LED lighting to enhance display
- Double-glazed doors for enhanced insulation
- UK 3 pin plug allows users to simply plug in and switch on



Ventus V90 Full Front - 800mm High											
MODEL	PRICE £	PRICE €	DESCRIPTION	DOOR HINGING	H	W	D	POWER	GAS TYPE	CAPACITY	WT
F76/272	£3179	€3656	Glass Door Stainless Steel	Left; Right	800	900	500	393W	R290	117 Bottles	81
F76/272/B	£3179	€3656	Glass Door Black Painted	Left; Right	800	900	500	393W	R290	117 Bottles	81

V90 Full Front Glass 800mm High Factory Fit Options

MODEL	PRICE £	PRICE €	DESCRIPTION	
Door Type				
0*	VS734	£65	€75	Solid Door - Stainless Steel - Change from Full Front Glass to Full Front Solid Door
0*	VS746	£65	€75	Solid Door - Black Painted - Change from Full Front Glass to Full Front Solid Door
0*	VS1014	£55	€64	Full Front Cladded Door - Stainless Steel - Change from Glass Door to Own Cladding - Customer Supplied Wood Panel
0*	VS1031	£69	€80	Full Front Cladded Door - Black Painted - Change from Glass Door to Own Cladding - Customer Supplied Wood Panel
Shelving Type				
0*	VS400	£218	€251	Perforated Shelving - Change from Standard Wire Shelves to Perforated Shelves
0*	VS360	£43	€49	Wine Shelving - Change from Standard Wire Shelves to Wine Shelves
Plug Type				
0*	VS401	£0	€0	EU 2-Pin Plug - Change from UK to EU Plug
De-gassed				
0*	VS1017	£111	€128	De-gassed Unit (Only Required to Make Suitable for Air Freighting)

0* Factory fitted option please request at point of ordering

Accessories

MODEL	PRICE £	PRICE €	DESCRIPTION	
A	A12/101	£108	€124	Chrome Wine Shelf
A	A12/092/Z1	£131	€151	Chrome Wire Shelf

2

YEAR

UK parts
and labour
warranty

Export
parts
warranty

on all IMC products

Ventus V90

Ventus V90 Full Front Reduced Depth - 450mm Deep

- Full front door for seamless integration
- Reduced 450mm depth
- Wide range of options available to customise your bottle cooler, ensure a perfect fit in any bar
- Elegant, flexible storage for up to 156 bottles
- Dynamic Air Distribution System coupled with efficient compressors and improved insulation ensures superior cooling times
- Electronic temperature control keeps drinks at the perfect serving temperature
- Energy efficient EcoSmart controller - at the touch of a button, put the bottle cooler into its most economical state until next required
- Sleek stainless steel interior and LED lighting to enhance display
- Twin double-glazed lockable doors for enhanced security
- UK 3 pin plug allows users to simply plug in and switch on



Ventus V90 Reduced Depth - 900mm High											
MODEL	PRICE £	PRICE €	DESCRIPTION	DOOR HINGING	H	W	D	POWER	GAS TYPE	CAPACITY	WT
F76/273	£3179	€3656	Glass Door Stainless Steel	Left; Right	900	900	450	410W	R290	156 Bottles	84
F76/273/B	£3179	€3656	Glass Door Black Painted	Left; Right	900	900	450	410W	R290	156 Bottles	84

V90 Reduced Depth 450mm Deep Factory Fit Options

MODEL	PRICE £	PRICE €	DESCRIPTION
Door Type			
0* VS732	£65	€75	Solid Door - Stainless Steel - Change from Standard Glass to Solid Door
0* VS744	£65	€75	Solid Door - Black Painted - Change from Standard Glass to Solid Door
Shelving Type			
Plug Type			
0* VS401	£0	€0	EU 2-Pin Plug - Change from UK to EU Plug
De-gassed			
0* VS1017	£111	€128	De-gassed Unit (Only Required to Make Suitable for Air Freighting)

0* Factory fitted option please request at point of ordering

2

UK parts
and labour
warranty

Export
parts
warranty

on all IMC products

Ventus V135

Ventus V135 Standard - 900mm High

- Wide range of options available to customise your bottle cooler, ensure a perfect fit in any bar
- Elegant, flexible storage for up to 310 bottles
- Dynamic Air Distribution System coupled with efficient compressors and improved insulation ensures superior cooling times
- Electronic temperature control keeps drinks at the perfect serving temperature
- Energy efficient EcoSmart controller - at the touch of a button, put the bottle cooler into its most economical state until next required
- Sleek stainless steel interior and LED lighting to enhance display
- Three double-glazed lockable doors for enhanced security
- UK 3 pin plug allows users to simply plug in and switch on



Ventus V135 Standard - 900mm High											
MODEL	PRICE £	PRICE €	DESCRIPTION	DOOR HINGING	H	W	D	POWER	GAS TYPE	CAPACITY	WT
F76/350	£4908	€5644	Glass Door Stainless Steel	Left; Right; Right	900	1350	500	664W	R290	310 Bottles	133
F76/350/B	£4908	€5644	Glass Door Black Painted	Left; Right; Right	900	1350	500	664W	R290	310 Bottles	133

V135 Standard 900mm High Factory Fit Options

MODEL	PRICE £	PRICE €	DESCRIPTION
Door Type			
0* VS537	£99	€114	Solid Door - Stainless Steel - Change from Standard Glass to Solid Door
0* VS1007	£99	€114	Solid Door - Black Painted - Change from Standard Glass to Solid Door
Shelving Type			
0* VS587	£268	€308	Perforated Shelving - Change from Standard Wire Shelves to Perforated Shelves
Plug Type			
0* VS401	£0	€0	EU 2-Pin Plug - Change from UK to EU Plug
De-gassed			
0* VS1017	£111	€128	De-gassed Unit (Only Required to Make Suitable for Air Freighting)

0* Factory fitted option please request at point of ordering

Accessories

MODEL	PRICE £	PRICE €	DESCRIPTION
A A12/102	£135	€155	Chrome Wine Shelf
A A12/099	£130	€149	Chrome Wire Shelf
A S76/153	£211	€243	Perforated Shelf

2
YEAR

UK parts
and labour
warranty

Export
parts
warranty

on all IMC products

Ventus V135

Ventus V135 Reduced Height - 800mm

- Reduced 800mm height
- Wide range of options available to customise your bottle cooler, ensure a perfect fit in any bar
- Elegant, flexible storage for up to 195 bottles
- Dynamic Air Distribution System coupled with efficient compressors and improved insulation ensures superior cooling times
- Electronic temperature control keeps drinks at the perfect serving temperature
- Energy efficient EcoSmart controller - at the touch of a button, put the bottle cooler into its most economical state until next required
- Sleek stainless steel interior and LED lighting to enhance display
- Three double-glazed lockable doors for enhanced security
- UK 3 pin plug allows users to simply plug in and switch on



Ventus V135 Reduced Height - 800mm											
MODEL	PRICE £	PRICE €	DESCRIPTION	DOOR HINGING	H	W	D	POWER	GAS TYPE	CAPACITY	WT
F76/352	£4908	€5644	Glass Door Stainless Steel	Left; Right; Right	800	1350	500	664W	R290	185 Bottles	128
F76/352/B	£4908	€5644	Glass Door Black Painted	Left; Right; Right	800	1350	500	664W	R290	185 Bottles	128

V135 Standard 800mm High Factory Fit Options

MODEL	PRICE £	PRICE €	DESCRIPTION
Door Type			
0* VS538	£99	€114	Solid Door - Stainless Steel - Change from Standard Glass to Solid Door
0* VS868	£99	€114	Solid Door - Black Painted - Change from Standard Glass to Solid Door
Shelving Type			
0* VS587	£268	€308	Perforated Shelving - Change from Standard Wire Shelves to Perforated Shelves
Plug Type			
0* VS401	£0	€0	EU 2-Pin Plug - Change from UK to EU Plug
De-gassed			
0* VS1017	£111	€128	De-gassed Unit (Only Required to Make Suitable for Air Freight)

0* Factory fitted option please request at point of ordering

Accessories

MODEL	PRICE £	PRICE €	DESCRIPTION
A A12/102	£135	€155	Chrome Wine Shelf
A A12/099	£130	€149	Chrome Wire Shelf
A S76/153	£211	€243	Perforated Shelf

2
YEARUK parts
and labour
warrantyExport
parts
warranty

on all IMC products

Ventus V135

Ventus V135 Full Front - 900mm High

- Full front door for seamless integration
- Wide range of options available to customise your bottle cooler, ensure a perfect fit in any bar
- Elegant, flexible storage for up to 310 bottles
- Dynamic Air Distribution System coupled with efficient compressors and improved insulation ensures superior cooling times
- Electronic temperature control keeps drinks at the perfect serving temperature
- Energy efficient EcoSmart controller - at the touch of a button, put the bottle cooler into its most economical state until next required
- Sleek stainless steel interior and LED lighting to enhance display
- Three double-glazed lockable doors for enhanced security
- UK 3 pin plug allows users to simply plug in and switch on



Ventus V135 Full Front - 900mm High											
MODEL	PRICE £	PRICE €	DESCRIPTION	DOOR HINGING	H	W	D	POWER	GAS TYPE	CAPACITY	WT
F76/370	£4908	€5644	Glass Door Stainless Steel	Left; Right; Right	900	1350	500	664W	R290	310 Bottles	133
F76/370/B	£4908	€5644	Glass Door Black Painted	Left; Right; Right	900	1350	500	664W	R290	310 Bottles	133

V135 Full Front Glass 900mm High Factory Fit Options

MODEL	PRICE £	PRICE €	DESCRIPTION
Door Type			
0* VS735	£99	€114	Solid Door - Stainless Steel - Change from Full Front Glass to Full Front Solid Door
0* VS747	£99	€114	Solid Door - Black Painted - Change from Full Front Glass to Full Front Solid Door
0* VS1015	£83	€96	Full Front Cladded Door - Stainless Steel - Change from Glass Door to Own Cladding - Customer Supplied Wood Panel
0* VS1032	£103	€120	Full Front Cladded Door - Black Painted - Change from Glass Door to Own Cladding - Customer Supplied Wood Panel
Shelving Type			
0* VS587	£268	€308	Perforated Shelving - Change from Standard Wire Shelves to Perforated Shelves
Plug Type			
0* VS401	£0	€0	EU 2-Pin Plug - Change from UK to EU Plug
De-gassed			
0* VS1017	£111	€128	De-gassed Unit (Only Required to Make Suitable for Air Freighting)

0* Factory fitted option please request at point of ordering

Accessories

MODEL	PRICE £	PRICE €	DESCRIPTION
A A12/099	£130	€149	Chrome Wine Shelf

2
YEAR

UK parts
and labour
warranty

Export
parts
warranty

on all IMC products

Ventus V135

Ventus V135 Full Front - 800mm High

- Reduced 800mm height
- Wide range of options available to customise your bottle cooler, ensure a perfect fit in any bar
- Elegant, flexible storage for up to 195 bottles
- Dynamic Air Distribution System coupled with efficient compressors and improved insulation ensures superior cooling times
- Electronic temperature control keeps drinks at the perfect serving temperature
- Energy efficient EcoSmart controller - at the touch of a button, put the bottle cooler into its most economical state until next required
- Sleek stainless steel interior and LED lighting to enhance display
- Three double-glazed lockable doors for enhanced security
- UK 3 pin plug allows users to simply plug in and switch on



Ventus V135 Full Front - 800mm High											
MODEL	PRICE £	PRICE €	DESCRIPTION	DOOR HINGING	H	W	D	POWER	GAS TYPE	CAPACITY	WT
F76/372	£4908	€5644	Glass Door Stainless Steel	Left; Right; Right	800	1350	500	664W	R290	185 Bottles	128
F76/372/B	£4908	€5644	Glass Door Black Painted	Left; Right; Right	800	1350	500	664W	R290	185 Bottles	128

V135 Full Front Glass 800mm High Factory Fit Options

MODEL	PRICE £	PRICE €	DESCRIPTION
Door Type			
0* VS737	£160	€191	Solid Door - Stainless Steel - Change from Full Front Glass to Full Front Solid Door
0* VS749	£161	€193	Solid Door - Black Painted - Change from Full Front Glass to Full Front Solid Door
0* VS1016	£83	€96	Full Front Cladded Door - Stainless Steel - Change from Glass Door to Own Cladding - Customer Supplied Wood Panel
0* VS1033	£103	€120	Full Front Cladded Door - Black Painted - Change from Glass Door to Own Cladding - Customer Supplied Wood Panel
Shelving Type			
0* VS587	£268	€308	Perforated Shelving - Change from Standard Wire Shelves to Perforated Shelves
Plug Type			
0* VS401	£0	€0	EU 2-Pin Plug - Change from UK to EU Plug
De-gassed			
0* VS1017	£111	€128	De-gassed Unit (Only Required to Make Suitable for Air Freighting)

0* Factory fitted option please request at point of ordering

Accessories

MODEL	PRICE £	PRICE €	DESCRIPTION
A A12/099	£130	€149	Chrome Wine Shelf

Ventus VR60

Ventus VR60 Glass Froster - 900mm High

- Wide range of options available to customise your glass froster, ensure a perfect fit in any bar
- Chills and frosts glasses, to enhance the taste and appearance of drinks
- Dynamic Air Distribution System coupled with efficient compressors and improved insulation ensures superior cooling times
- Rapid chill to -10°C to keep drinks colder for longer
- Energy efficient EcoSmart controller - at the touch of a button, put the glass froster into its most economical state until next required
- Efficient design means up to 50 pint glasses can be chilled at the same time
- Front loading design ensures fast and easy access to ice cold glasses
- Stylish stainless steel exterior to suit any commercial bar setting
- UK 3 pin plug - simply plug in and switch on



Ventus VR60 Glass Froster - 900mm High											
MODEL	PRICE £	PRICE €	DESCRIPTION	DOOR HINGING	H	W	D	POWER	CAPACITY		WT
F49/600	£3114	€3581	Glass Door Stainless Steel	Right	900	600	500	667W	50 x standard pint glasses		65
F49/600/B	£3114	€3581	Glass Door Black Painted	Right	900	600	500	667W	50 x standard pint glasses		65

VR60 Standard 900mm High Factory Fit Options

MODEL	PRICE £	PRICE €	DESCRIPTION
Door Type			
0* VS644	£40	€46	Solid Door - Stainless Steel - Change from Standard Glass to Solid Door
0* VS794	£40	€46	Solid Door - Black Painted - Change from Standard Glass to Solid Door
0* VS642	£34	€40	Left Hinged Glass Door - Stainless Steel - Change from Standard Glass to Left Hinged Glass Door
0* VS1008	£34	€40	Left Hinged Glass Door - Black Painted - Change from Standard Glass to Left Hinged Glass Door
0* VS646	£34	€40	Left Hinged Solid Door - Stainless Steel - Change from Standard Solid to Left Hinged Solid Door
0* VS796	£34	€40	Left Hinged Solid Door - Black Painted - Change from Standard Solid to Left Hinged Solid Door
Plug Type			
0* VS401	£0	€0	EU 2-Pin Plug - Change from UK to EU Plug
De-gassed			
0* VS1017	£111	€128	De-gassed Unit (Only Required to Make Suitable for Air Freight)

0* Factory fitted option please request at point of ordering

Ventus VR60

Ventus VR60 Glass Froster - 800mm High

- Reduced 800mm height
- Wide range of options available to customise your glass froster, ensure a perfect fit in any bar
- Chills and frosts glasses, to enhance the taste and appearance of drinks
- Dynamic Air Distribution System coupled with efficient compressors and improved insulation ensures superior cooling times
- Rapid chill to -10°C to keep drinks colder for longer
- Energy efficient EcoSmart controller - at the touch of a button, put the glass froster into its most economical state until next required
- Efficient design means up to 50 pint glasses can be chilled at the same time
- Front loading design ensures fast and easy access to ice cold glasses
- Stylish stainless steel exterior to suit any commercial bar setting
- UK 3 pin plug - simply plug in and switch on



Ventus VR60 Glass Froster - 800mm High											
MODEL	PRICE £	PRICE €	DESCRIPTION	DOOR HINGING	H	W	D	POWER	CAPACITY		WT
F49/602	£3114	€3581	Glass Door Stainless Steel	Right	800	600	500	667W	50 x standard pint glasses		65
F49/602/B	£3114	€3581	Glass Door Black Painted	Right	800	600	500	667W	50 x standard pint glasses		65

VR60 Standard 800mm High Factory Fit Options

MODEL	PRICE £	PRICE €	DESCRIPTION
Door Type			
0* VS645	£40	€46	Solid Door - Stainless Steel - Change from Standard Glass to Solid Door
0* VS795	£40	€46	Solid Door - Black Painted - Change from Standard Glass to Solid Door
0* VS643	£34	€40	Left Hinged Glass Door - Stainless Steel - Change from Standard Glass to Left Hinged Glass Door
0* VS838	£34	€40	Left Hinged Glass Door - Black Painted - Change from Standard Glass to Left Hinged Glass Door
0* VS647	£34	€40	Left Hinged Solid Door - Stainless Steel - Change from Standard Solid to Left Hinged Solid Door
0* VS797	£36	€41	Left Hinged Solid Door - Black Painted - Change from Standard Solid to Left Hinged Solid Door
Plug Type			
0* VS401	£0	€0	EU 2-Pin Plug - Change from UK to EU Plug
De-gassed			
0* VS1017	£111	€128	De-gassed Unit (Only Required to Make Suitable for Air Freighting)

0* Factory fitted option please request at point of ordering

Ventus VR60

Ventus VR60 Full Front Glass Froster - 900mm High

- Full front door for seamless integration
- Wide range of options available to customise your glass froster, ensure a perfect fit in any bar
- Chills and frosts glasses, to enhance the taste and appearance of drinks
- Dynamic Air Distribution System coupled with efficient compressors and improved insulation ensures superior cooling times
- Rapid chill to -10°C to keep drinks colder for longer
- Energy efficient EcoSmart controller - at the touch of a button, put the glass froster into its most economical state until next required
- Efficient design means up to 50 pint glasses can be chilled at the same time
- Front loading design ensures fast and easy access to ice cold glasses
- Stylish stainless steel exterior to suit any commercial bar setting
- UK 3 pin plug - simply plug in and switch on



Ventus VR60 Full Front Glass Froster - 900mm High											
MODEL	PRICE £	PRICE €	DESCRIPTION	DOOR HINGING	H	W	D	POWER	CAPACITY	WT	
F49/620	£3114	€3581	Glass Door Stainless Steel	Right	900	600	500	667W	50 x standard pint glasses	65	
F49/620/B	£3114	€3581	Glass Door Black Painted	Right	900	600	500	667W	50 x standard pint glasses	65	

VR60 Full Front 900mm High Factory Fit Options

MODEL	PRICE £	PRICE €	DESCRIPTION
Door Type			
0* VS804	£58	€68	Solid Door - Stainless Steel - Change from Standard Glass to Solid Door
0* VS805	£24	€28	Solid Door - Black Painted - Change from Standard Glass to Solid Door
0* VS918	£41	€47	Left Hinged Glass Door - Stainless Steel - Change from Standard Glass to Left Hinged Glass Door
0* VS1019	£41	€47	Left Hinged Glass Door - Black Painted - Change from Standard Glass to Left Hinged Glass Door
0* VS833	£48	€55	Left Hinged Solid Door - Stainless Steel - Change from Standard Solid to Left Hinged Solid Door
0* VS1021	£62	€71	Left Hinged Solid Door - Black Painted - Change from Standard Solid to Left Hinged Solid Door
0* VS771	£41	€47	Door for Wood Cladding - Stainless Steel - Change from Standard to Frame for Wood Cladding
0* VS772	£41	€47	Door for Wood Cladding - Black Painted - Change from Standard to Frame for Wood Cladding
0* VS777	£36	€42	Left Hinged Door for Wood Cladding - Stainless Steel - Change from Standard to Left Hinged Frame for Wood Cladding
0* VS778	£36	€42	Left Hinged Door for Wood Cladding - Black Painted - Change from Standard to Left Hinged Frame for Wood Cladding
Plug Type			
0* VS401	£0	€0	EU 2-Pin Plug - Change from UK to EU Plug
De-gassed			
0* VS1017	£111	€128	De-gassed Unit (Only Required to Make Suitable for Air Freighting)

0* Factory fitted option please request at point of ordering

2 YEAR
UK parts and labour
warranty
Export parts
warranty
on all IMC products

Ventus VR60 Full Front Glass Froster - 800mm High

- Full front door for seamless integration
- Reduced 800mm height
- Wide range of options available to customise your glass froster, ensure a perfect fit in any bar
- Chills and frosts glasses, to enhance the taste and appearance of drinks
- Dynamic Air Distribution System coupled with efficient compressors and improved insulation ensures superior cooling times
- Rapid chill to -10°C to keep drinks colder for longer
- Energy efficient EcoSmart controller - at the touch of a button, put the glass froster into its most economical state until next required
- Efficient design means up to 50 pint glasses can be chilled at the same time
- Front loading design ensures fast and easy access to ice cold glasses
- Stylish stainless steel exterior to suit any commercial bar setting
- UK 3 pin plug - simply plug in and switch on



Ventus VR60 Full Front Glass Froster - 800mm High											
MODEL	PRICE £	PRICE €	DESCRIPTION	DOOR HINGING	H	W	D	POWER	CAPACITY		WT
F49/622	£3114	€3581	Glass Door Stainless Steel	Right	800	600	500	687W	50 x standard pint glasses		65
F49/622/B	£3114	€3581	Glass Door Black Painted	Right	800	600	500	687W	50 x standard pint glasses		65

VR60 Full Front 800mm High Factory Fit Options

MODEL	PRICE £	PRICE €	DESCRIPTION
Door Type			
0* VS645	£40	€46	Solid Door - Stainless Steel - Change from Standard Glass to Solid Door
0* VS1018	£43	€49	Solid Door - Black Painted - Change from Standard Glass to Solid Door
0* VS917	£41	€47	Left Hinged Glass Door - Stainless Steel - Change from Standard Glass to Left Hinged Glass Door
0* VS1020	£41	€47	Left Hinged Glass Door - Black Painted - Change from Standard Glass to Left Hinged Glass Door
0* VS1022	£62	€71	Left Hinged Solid Door - Stainless Steel - Change from Standard Solid to Left Hinged Solid Door
0* VS1023	£62	€71	Left Hinged Solid Door - Black Painted - Change from Standard Solid to Left Hinged Solid Door
0* VS768	£41	€47	Door for Wood Cladding - Stainless Steel - Change from Standard to Frame for Wood Cladding
0* VS769	£41	€47	Door for Wood Cladding - Black Painted - Change from Standard to Frame for Wood Cladding
0* VS774	£36	€42	Left Hinged Door for Wood Cladding - Stainless Steel - Change from Standard to Left Hinged Frame for Wood Cladding
0* VS775	£36	€42	Left Hinged Door for Wood Cladding - Black Painted - Change from Standard to Left Hinged Frame for Wood Cladding
Plug Type			
0* VS401	£0	€0	EU 2-Pin Plug - Change from UK to EU Plug
De-gassed			
0* VS1017	£111	€128	De-gassed Unit (Only Required to Make Suitable for Air Freighting)

0* Factory fitted option please request at point of ordering



Mistral



Whether it's keeping beverages at perfect serving temperature or frosting glasses to enhance the appearance of drinks, we have an array of solutions.

We offer a wide variety of bottle coolers to suit any bar setting. With precise temperature control and rapid chill, our energy-efficient bottle coolers are the perfect showcase for drinks. Mistral models allow easy access for quick service and are available in a range of stylish designs and space-saving sizes.

With rapid chill, our energy-efficient range of glass frosters helps bars to deliver high-quality drinks every time. Mistral provides easy access for quick service and is available in a range of sleek designs, with varying capacities.

Ideally suited for...



Bars

Speed up service and generate customer satisfaction with great-tasting drinks.



Restaurants

Enhance your customers' dining experience by serving high-quality drinks alongside delicious food. Make sure they are perfectly-presented and taste great with Mistral.



Hotels

Attract customers in your hotel's bar with a stylish bottle cooler or glass froster. Show your drinks in their best light in a well-designed unit that enhances your offer.



Cafes and coffee shops

Encourage customers to spend by tempting them with well-presented drinks. Highlight your offer and ensure great-tasting beverages with a Mistral unit.

Deliver ice cold drinks with visual appeal with Mistral bottle coolers and glass frosters.

Benefits at a glance

- Chills bottles and frosts glasses to add visual appeal to drinks
- Precise temperature control
- Stylish exterior design
- Large capacity

Mistral M60

Mistral M60 Standard - 900mm High

- Stylish, flexible storage for up to 120 bottles
- Electronic temperature controller and auto defrost for perfectly-chilled drinks
- Energy-efficient forced air cooling for rapid temperature pull down
- Sleek stainless steel interior to enhance display
- Single double-glazed lockable door for enhanced security
- UK 3 pin plug allows users to simply plug in and switch on
- Easy to remove and replace magnetic gaskets to facilitate cleaning



Mistral M60 Standard - 900mm high											
MODEL	PRICE £	PRICE €	DESCRIPTION	DOOR HINGING	H	W	D	POWER	GAS TYPE	CAPACITY	WT
F77/150	£1955	€2249	Glass Door Stainless Steel	Right	900	600	500	225W	R290	120 Bottles	65
F77/150/B	£1955	€2249	Glass Door Black Painted	Right	900	600	500	225W	R290	120 Bottles	65

MODEL	PRICE £	PRICE €	DESCRIPTION
A A12/100	£140	€161	Chrome Wine Shelf
A A12/091/Z1	£70	€81	Chrome Wire Shelf
O* VS1017	£111	€128	De-gassed unit (only required to make suitable for Air Freight)
O* VS401	£0	€0	Euro Plug

O* Factory fitted option please request at point of ordering

Mistral M60 Reduced Height - 850mm High

- Reduced 850mm height
- Stylish, flexible storage for up to 78 bottles
- Electronic temperature controller and auto defrost for perfectly-chilled drinks
- Energy-efficient forced air cooling for rapid temperature pull down
- Sleek stainless steel interior to enhance display
- Single double-glazed lockable door for enhanced security
- UK 3 pin plug allows users to simply plug in and switch on
- Easy to remove and replace magnetic gaskets to facilitate cleaning



Mistral M60 Reduced Height - 850mm high											
MODEL	PRICE £	PRICE €	DESCRIPTION	DOOR HINGING	H	W	D	POWER	GAS TYPE	CAPACITY	WT
F77/151	£1955	€2249	Glass Door Stainless Steel	Right	850	600	500	225W	R290	78 Bottles	58
F77/151/B	£1955	€2249	Glass Door Black Painted	Right	850	600	500	225W	R290	78 Bottles	58

MODEL	PRICE £	PRICE €	DESCRIPTION
A A12/100	£140	€161	Chrome Wine Shelf
A A12/091/Z1	£70	€81	Chrome Wire Shelf
O* VS1017	£111	€128	De-gassed unit (only required to make suitable for Air Freight)
O* VS401	£0	€0	Euro Plug

O* Factory fitted option please request at point of ordering

Mistral M60

Mistral M60 Reduced Height - 800mm High

- Reduced 800mm height
- Stylish, flexible storage for up to 78 bottles
- Electronic temperature controller and auto defrost for perfectly-chilled drinks
- Energy-efficient forced air cooling for rapid temperature pull down
- Sleek stainless steel interior to enhance display
- Single double-glazed lockable door for enhanced security
- UK 3 pin plug allows users to simply plug in and switch on
- Easy to remove and replace magnetic gaskets to facilitate cleaning



Mistral M60 Standard - 900mm high											
MODEL	PRICE £	PRICE €	DESCRIPTION	DOOR HINGING	H	W	D	POWER	GAS TYPE	CAPACITY	WT
F77/152	£1955	€2249	Glass Door Stainless Steel	Right	800	600	500	225W	R290	120 Bottles	57
F77/152/B	£1955	€2249	Glass Door Black Painted	Right	800	600	500	225W	R290	120 Bottles	57

MODEL	PRICE £	PRICE €	DESCRIPTION
A A12/100	£140	€161	Chrome Wine Shelf
A A12/091/Z1	£70	€81	Chrome Wire Shelf
0* VS1017	£111	€128	De-gassed unit (only required to make suitable for Air Freight)
0* VS401	£0	€0	Euro Plug

0* Factory fitted option please request at point of ordering

Mistral M60 - High Ambient

- Stylish storage of up to 135 bottles in ambient conditions of up to 43°C
- Electronic temperature controller and auto defrost for perfectly-chilled drinks
- Energy-efficient forced air cooling for rapid temperature pull down
- Sleek stainless steel interior to enhance display
- Single double-glazed or solid lockable door for enhanced security
- UK 3 pin plug allows users to simply plug in and switch on
- Easy to remove and replace magnetic gaskets to facilitate cleaning



Mistral M60 - High Ambient											
MODEL	PRICE £	PRICE €	DESCRIPTION	DOOR HINGING	H	W	D	POWER	GAS TYPE	CAPACITY	WT
F77/114/SS	£2936	€3376	Glass Door Stainless Steel	Right	900	600	500	219W	R290	135 Bottles	64.5
F77/115/SS	£2936	€3376	Solid Door Stainless Steel	Right	900	600	500	219W	R290	135 Bottles	64.5

MODEL	PRICE £	PRICE €	DESCRIPTION
A A12/100	£140	€161	Chrome Wine Shelf
A A12/091/Z1	£70	€81	Chrome Wire Shelf
0* VS1017	£111	€128	De-gassed unit (only required to make suitable for Air Freight)
0* VS401	£0	€0	Euro Plug

0* Factory fitted option please request at point of ordering

Mistral M90

Mistral M90 Standard - 900mm High

- Stylish, flexible storage for up to 195 bottles
- Electronic temperature controller and auto defrost for perfectly-chilled drinks
- Energy-efficient forced air cooling for rapid temperature pull down
- Sleek stainless steel interior to enhance display
- Double-glazed lockable doors for enhanced security
- UK 3 pin plug allows users to simply plug in and switch on
- Easy to remove and replace magnetic gaskets to facilitate cleaning



Mistral M90 Standard - 900mm high											
MODEL	PRICE £	PRICE €	DESCRIPTION	DOOR HINGING	H	W	D	POWER	GAS TYPE	CAPACITY	WT
F77/250	£2689	€3094	Glass Door Stainless Steel	Left, Right	900	900	500	232W	R290	195 Bottles	80
F77/250/B	£2689	€3094	Glass Door Black Painted	Left, Right	900	900	500	232W	R290	195 Bottles	80

MODEL	PRICE £	PRICE €	DESCRIPTION
A A12/101	£108	€124	Chrome Wine Shelf
A A12/092/Z1	£131	€151	Chrome Wire Shelf
0* VS1017	£111	€128	De-gassed unit (only required to make suitable for Air Freight)
0* VS401	£0	€0	Euro Plug

0* Factory fitted option please request at point of ordering

Mistral M90 - With Sliding Doors

- Stylish, flexible storage for up to 204 bottles
- Electronic temperature controller and auto defrost for perfectly-chilled drinks
- Energy-efficient forced air cooling for rapid temperature pull down
- Sleek stainless steel interior to enhance display
- Sliding, lockable doors for enhanced security
- UK 3 pin plug allows users to simply plug in and switch on
- Easy to remove and replace magnetic gaskets to facilitate cleaning



Mistral M90 - With sliding doors											
MODEL	PRICE £	PRICE €	DESCRIPTION	DOOR HINGING	H	W	D	POWER	GAS TYPE	CAPACITY	WT
F77/700/SS	£2859	€3289	Glass Door Stainless Steel	Sliding	900	900	520	460W	R290	204 Bottles	86
F77/700/BS	£2859	€3289	Glass Door Black Painted	Sliding	900	900	520	460W	R290	204 Bottles	86

MODEL	PRICE £	PRICE €	DESCRIPTION
A A12/101	£108	€124	Chrome Wine Shelf
A A12/092/Z1	£131	€151	Chrome Wire Shelf
0* VS1017	£111	€128	De-gassed unit (only required to make suitable for Air Freight)
0* VS401	£0	€0	Euro Plug

0* Factory fitted option please request at point of ordering

Mistral M90

Mistral M90 Reduced Height - 850mm High

- Reduced 850mm height
- Stylish, flexible storage for up to 117 bottles
- Precise electronic temperature controller and auto defrost for perfectly-chilled drinks

- Energy-efficient forced air cooling for rapid temperature pull down
- Sleek stainless steel interior to enhance display
- Double-glazed lockable doors for enhanced security
- UK 3 pin plug allows users to simply plug in and switch on



Mistral M90 Reduced Height - 850mm high											
MODEL	PRICE £	PRICE €	DESCRIPTION	DOOR HINGING	H	W	D	POWER	GAS TYPE	CAPACITY	WT
F77/251	£2689	€3094	Glass Door Stainless Steel	Left, Right	850	900	500	232W	R290	117 Bottles	77
F77/251/B	£2689	€3094	Glass Door Black Painted	Left, Right	850	900	500	232W	R290	117 Bottles	77

MODEL	PRICE £	PRICE €	DESCRIPTION
A A12/101	£108	€124	Chrome Wine Shelf
A A12/092/Z1	£131	€151	Chrome Wire Shelf
0* VS1017	£111	€128	De-gassed unit (only required to make suitable for Air Freight)
0* VS401	£0	€0	Euro Plug

0* Factory fitted option please request at point of ordering

Mistral M90 Reduced Height - 800mm High

- Reduced 800mm height
- Stylish, flexible storage for up to 117 bottles
- Precise electronic temperature controller and auto defrost for perfectly-chilled drinks

- Energy-efficient forced air cooling for rapid temperature pull down
- Sleek stainless steel interior to enhance display
- Double-glazed lockable doors for enhanced security
- UK 3 pin plug allows users to simply plug in and switch on.



Mistral M90 Reduced Height - 800mm high											
MODEL	PRICE £	PRICE €	DESCRIPTION	DOOR HINGING	H	W	D	POWER	GAS TYPE	CAPACITY	WT
F77/252	£2689	€3094	Glass Door Stainless Steel	Left, Right	800	900	500	232W	R290	117 Bottles	74
F77/252/B	£2689	€3094	Glass Door Black Painted	Left, Right	800	900	500	232W	R290	117 Bottles	74

MODEL	PRICE £	PRICE €	DESCRIPTION
A A12/101	£108	€124	Chrome Wine Shelf
A A12/092/Z1	£131	€151	Chrome Wire Shelf
0* VS1017	£111	€128	De-gassed unit (only required to make suitable for Air Freight)
0* VS401	£0	€0	Euro Plug

0* Factory fitted option please request at point of ordering

Mistral M90

Mistral M90 - High Ambient

- Stylish storage of up to 204 bottles in ambient conditions of up to 43°C
- Precise electronic temperature controller and auto defrost for perfectly-chilled drinks
- Energy-efficient forced air cooling for rapid temperature pull down
- Sleek stainless steel interior to enhance display
- Double-glazed lockable doors for enhanced security
- UK 3 pin plug allows users to simply plug in and switch on
- Easy to remove and replace magnetic gaskets to facilitate cleaning
- Ambient temperatures to 43°C



Mistral M90 - High ambient											
MODEL	PRICE £	PRICE €	DESCRIPTION	DOOR HINGING	H	W	D	POWER	GAS TYPE	CAPACITY	WT
F77/232/SS	£5084	€5847	Glass Door Stainless Steel	Left, Right	900	900	500	354W	R290	204 Bottles	85.5
F77/233/SS	£5084	€5847	Solid Door Stainless Steel	Left, Right	900	900	500	354W	R290	204 Bottles	85.5

MODEL	PRICE £	PRICE €	DESCRIPTION
A A12/101	£108	€124	Chrome Wine Shelf
A A12/092/Z1	£131	€151	Chrome Wire Shelf
O* VS1017	£111	€128	De-gassed unit (only required to make suitable for Air Freight)
O* VS401	£0	€0	Euro Plug

O* Factory fitted option please request at point of ordering

Mistral M135

Mistral M135 Standard - 900mm High

- Stylish, flexible storage for up to 310 bottles
- Precise electronic temperature controller and auto defrost for perfectly-chilled drinks
- Energy-efficient forced air cooling for rapid temperature pull down
- Sleek stainless steel interior to enhance display
- Double-glazed lockable doors for enhanced security
- UK 3 pin plug allows users to simply plug in and switch on
- Easy to remove and replace magnetic gaskets to facilitate cleaning



Mistral M135 Standard - 900mm high											
MODEL	PRICE £	PRICE €	DESCRIPTION	DOOR HINGING	H	W	D	POWER	GAS TYPE	CAPACITY	WT
F77/350	£4047	€4655	Glass Door Stainless Steel	Left & 2 x Right	900	1350	500	357W	R290	310 Bottles	119.5
F77/350/B	£4047	€4655	Glass Door Black Painted	Left & 2 x Right	900	1350	500	357W	R290	310 Bottles	119.5

MODEL	PRICE £	PRICE €	DESCRIPTION
A A12/099	£130	€149	Chrome Wire Shelf
0* VS1017	£111	€128	De-gassed unit (only required to make suitable for Air Freight)
0* VS401	£0	€0	Euro Plug

0* Factory fitted option please request at point of ordering

Mistral M135 Reduced Height - 800mm High

- Reduced 800mm height
- Stylish, flexible storage for up to 185 bottles
- Precise electronic temperature controller and auto defrost for perfectly-chilled drinks
- Energy-efficient forced air cooling for rapid temperature pull down
- Sleek stainless steel interior to enhance display
- Double-glazed lockable doors for enhanced security
- UK 3 pin plug allows users to simply plug in and switch on



Mistral M135 Reduced Height - 800mm high											
MODEL	PRICE £	PRICE €	DESCRIPTION	DOOR HINGING	H	W	D	POWER	GAS TYPE	CAPACITY	WT
F77/352	£4047	€4655	Glass Door Stainless Steel	Left & 2 x Right	800	1350	500	357W	R290	185 Bottles	122
F77/352/B	£4047	€4655	Glass Door Black Painted	Left & 2 x Right	800	1350	500	357W	R290	185 Bottles	122

MODEL	PRICE £	PRICE €	DESCRIPTION
A A12/099	£130	€149	Chrome Wire Shelf
0* VS1017	£111	€128	De-gassed unit (only required to make suitable for Air Freight)
0* VS401	£0	€0	Euro Plug

0* Factory fitted option please request at point of ordering

Mistral TC60

Mistral TC60 - Full front glass

- Tall, space-saving storage for up to 272 bottles
- Reversible door
- Precise electronic temperature controller and auto defrost for perfectly-chilled drinks
- Energy-efficient forced air cooling for rapid temperature pull down
- Sleek stainless steel interior to enhance display
- Double-glazed doors
- UK 3 pin plug allows users to simply plug in and switch on
- Easy to remove and replace magnetic gaskets to facilitate cleaning



Mistral TC60 - Full front glass											
MODEL	PRICE £	PRICE €	DESCRIPTION	DOOR HINGING	H	W	D	POWER	GAS TYPE	CAPACITY	WT
F77/560	£2859	€3289	Glass Door Stainless Steel	Right	1850	600	500	759W	R290	272 Bottles	101
F77/560/B	£2859	€3289	Glass Door Black Painted	Right	1850	600	500	759W	R290	272 Bottles	101

MODEL	PRICE £	PRICE €	DESCRIPTION
A A12/082	£107	€123	Chrome Wine Shelf
A A12/041/Z2	£82	€94	Chrome Wire Shelf
0* VS1017	£111	€128	De-gassed unit (only required to make suitable for Air Freight)
0* VS401	£0	€0	Euro Plug

0* Factory fitted option please request at point of ordering

Mistral TC60

Mistral TC60 – Full front glass with lockable door

- Tall, space-saving storage for up to 272 bottles
- Electronic temperature controller and auto defrost for perfectly-chilled drinks
- Energy-efficient forced air cooling for rapid temperature pull down
- Sleek stainless steel interior and LED lighting to enhance display
- Double-glazed lockable door for enhanced security
- UK 3 pin plug allows users to simply plug in and switch on
- Easy to remove and replace magnetic gaskets to facilitate cleaning



Mistral TC60 – Full front glass											
MODEL	PRICE £	PRICE €	DESCRIPTION	DOOR HINGING	H	W	D	POWER	GAS TYPE	CAPACITY	WT
F77/510	£2859	€3289	Glass Door Stainless Steel	Right	1850	600	500	759W	R290	272 Bottles	98
F77/510/B	£2859	€3289	Glass Door Black Painted	Right	1850	600	500	759W	R290	272 Bottles	98

MODEL	PRICE £	PRICE €	DESCRIPTION
A A12/082	£107	€123	Chrome Wine Shelf
A A12/041/Z2	£82	€94	Chrome Wire Shelf
0* VS1017	£111	€128	De-gassed unit (only required to make suitable for Air Freight)
0* VS401	£0	€0	Euro Plug

0* Factory fitted option please request at point of ordering

2 YEAR
UK parts and labour warranty
Export parts warranty
on all IMC products



bm

BOTTLE COOLERS



With innovative design and reliable performance, BM bottle coolers are ideal for busy bars.

Featuring a top-loading door, BM bottle coolers are designed for underbar use. They allow bartenders quick access to drinks - providing a perfect storage solution at busy times, when service and stocking are paramount.

Available in two width variations, the BM range perfectly integrates with our Bartender® range of modular underbar systems. Energy-efficient, rapid cooling technology keeps drinks at the ideal serving temperature, whilst innovative shelving makes restocking swift and service quicker.

Ideally suited for...



Bars

Speed up service and generate customer satisfaction with great-tasting drinks. BM bottle coolers can help you deliver.



Restaurants

Enhance your customers' dining experience by serving high-quality drinks alongside delicious food. Keep your beverages at perfect temperature with BM.



Clubs

Need to serve a high volume of customers at the same time? With easy access and large storage capacities, BM can help you meet high demand through your busiest periods.

Serve perfectly-chilled drinks at speed with BM's top-loading bottle coolers.

Benefits at a glance

- Top-loading design for easy access
- Rapid chill for quick service
- Precise temperature control
- Energy efficient
- UK 3 pin plug
- Stylish exterior design for underbar systems

BM70 Top Loading Bottle Cooler

- Top loading design, with sliding cover, ensures fast and easy access to ice cold drinks.
- Rapid cooling so drinks can be served quickly.
- Stylish, vertical storage for 140 bottles.
- Interior lighting and shelving for enhanced display and storage.
- Stylish exterior to suit any commercial bar setting.
- UK 3 pin plug allows users to simply plug in and switch on.



Bottle Basket

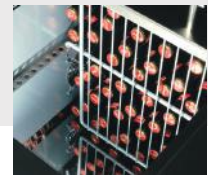

Divider Pack

BM70 Top Loading Bottle Cooler										
MODEL	PRICE £	PRICE €	DESCRIPTION	DOOR OPENING	H	W	D	POWER	CAPACITY	WT
F73/070/SS	£2828	€3252	BM with stainless steel lid	Top (sliding)	875	700	560	345W	140 Bottles	80
F73/071/SS	£2991	€3439	BM with glass lid	Top (sliding)	875	700	560	345W	140 Bottles	80
F73/072/SS	£2872	€3302	BM Bartender with stainless steel lid	Top (sliding)	950	700	560	345W	140 Bottles	80.5
F73/073/SS	£3030	€3485	BM Bartender with glass lid	Top (sliding)	950	700	560	345W	140 Bottles	80.5

MODEL	PRICE £	PRICE €	DESCRIPTION
A A12/089	£226	€260	Bottle Basket (each) - 4 required
A S73/004	£101	€117	Bottle opener and catcher
O* VS326	£286	€330	Speed Rail
O* VS321A	£181	€207	Internal light
O* VS1017	£111	€128	De-gassed unit (only required to make suitable for Air Freight)
O* VS401	£0	€0	Euro Plug

O* Factory fitted option please request at point of ordering

Frostar



Enhance the taste and appearance of drinks with Frostar glass frosters.

Nothing beats a cocktail or beer served in an ice cold, frosted glass. Frostar frosters ensure rapid cooling and frosting of all type of glasses.

The perfect partner for any busy bar setting, Frostar frosters chill glasses to -17°C to keep drinks colder for longer, removing the need for ice, which

dilutes taste. This makes them the ideal choice for cocktails, beers and champagne. With a top-loading design, they enable staff to deliver high-quality, ice cold beverages quickly and efficiently.

Ideally suited for...



Bars

Want to keep customers coming back? Serve drinks that look fantastic and taste great. Frostar frosters deliver ice cold glasses that enhance visual appeal and keep beverages colder for longer.



Restaurants

Complement a strong food menu with sensational cocktails and ice cold beers. Make sure they are perfectly-presented and taste great with Frostar.



Clubs

Serve ice cold drinks with visual appeal with Frostar. With easy access, large storage capacities and rapid chill, keep the drinks flowing through your busiest periods.

Serve perfectly-presented, great-tasting drinks with speed with Frostar glass frosters.

Benefits at a glance

- Chills and frosts glasses to add visual appeal to drinks
- Rapid cooling to -17°C
- Precise temperature control
- Stylish exterior design
- Large capacity
- Quick and easy access to glasses

Frostar FR60

Frostar FR60 Top Loading Glass Froster

- Chills and frosts glasses, to enhance the taste and appearance of drinks
- Rapid chill to -17°C to keep drinks colder for longer
- Efficient design means up to 75 glasses can be chilled at the same time
- Top loading with sliding cover for quick and easy access
- Stylish stainless steel exterior to suit any commercial bar setting
- UK 3 pin plug - simply plug in and switch on



Frostar FR60 Top Loading Glass Froster											
MODEL	PRICE £	PRICE €	DESCRIPTION	DOOR HINGING	H	W	D	POWER	CAPACITY		WT
F49/400/SS	£3472	€3994	Stainless Steel Exterior	Top (Sliding)	900	600	620	623W	75 standard sized pint glasses		63.5
F49/400/BS	£3472	€3994	Black Exterior	Top (Sliding)	900	600	620	623W	75 standard sized pint glasses		63.5

MODEL	PRICE £	PRICE €	DESCRIPTION
A BA52/060	£240	€277	Speed Rail
A S49/017	£106	€123	Bottle opener and cap catcher
0* VS1017	£111	€128	De-gassed unit (only required to make suitable for Air Freight)
0* VS401	£0	€0	Euro Plug

0* Factory fitted option please request at point of ordering



Vegetable Preparation

• Peelers • Chippers



Prepare a high volume of vegetables at speed with IMC's vegetable preparation solutions.

From peeling potatoes to washing shellfish and creating chips, we have a variety of vegetable preparation equipment to make life easier and speed up service.

Our range spans peelers and chippers, all of which have a compact, flexible design to suit kitchens of any size.

Ideally suited for...



Fish and chip shops

Fast service is crucial in fish and chip shops. IMC veg prep equipment delivers quick turnaround times on your potato peeling and chipping.



Pubs and restaurants

In busy kitchens, make food preparation quick and easy allowing you to focus your efforts on cooking and serving.

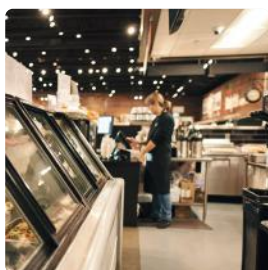

Fast food outlets

Take the stress out of busy periods with a high-volume, high-speed veg prep equipment to help you deliver food, fast.

Benefits at a glance

- Prepare vegetables at speed
- Simple and safe to operate
- Easy to clean
- Easy to maintain
- Robust construction
- Variety of sizes and outputs to suit the scale of your operation

Contents



VQ
PEELER

Potato Peelers

Save time and effort with a VQ Peeler

Ideally suited for:

Restaurants, pubs, fish and chips shops, fast food outlets. Peel potatoes at speed within a small footprint.

Why choose a VQ Peeler?

- Simple and safe to operate
- Able to peel potatoes at speed
- Small footprint
- Easy to clean
- Robust construction

Find out more on page

i63



SP
PEELER

Potato Peelers

Amongst the fastest potato peelers on the market

Ideally suited for:

Restaurants, pubs, fish and chips shops, fast food outlets. For high-speed peeling and high output, invest in a SP Peeler

Why choose a SP Peeler?

- Simple and safe to operate
- Able to peel high volumes of potatoes fast
- Compact footprint
- Easy to maintain
- Long - lasting robust construction

Find out more on page

i65



MF
MULTIFUNCTIONAL
PEELER

Vegetable Peelers

Versatile and available in a range of sizes, MF Peelers produce perfectly-prepared vegetables

Ideally suited for:

Restaurants and pubs. Multi-functional and efficient, the MF range saves operators valuable time

Why choose a MF Peeler?

- Easily adjustable timer
- Versatile
- Cost effective
- Simple and safe to operate
- Easy to maintain
- Built to fast

Find out more on page

i67



IMChip
Potato Chippers

Potato Chippers

Produce 25kg of chips per minute

Ideally suited for:

Fish and Chip Shops

Why choose an IMChip?

- Safe to operate
- High output - 25kg per minute
- Compact design
- Provides minimal waste
- Robustly engineered
- Easy to clean
- Easy to load

Find out more on page

i71

All prices are exclusive of VAT.

2
YEAR

UK parts and labour warranty

Export parts warranty

on all IMC products

UK

Goods are normally delivered free of charge to either the dealers' address or direct within 3 working days. If overnight and/or premium services are required charges will apply.

Export

Goods are priced ex works, export packaging is included.

UK Tel: 01522 875500

Export Tel: +44 1522 503250

UK e-mail: sales@lincat.co.uk

Export e-mail: export@lincat.co.uk





Peelers and Chippers

Multifunctional Peelers

	VQ3.5	VQ7	SP12	SP25	MF5	MF10	MF15	MF5L	MF10L	MF15L
PAGE	i64	i64	i66	i66	i68	i69 & 70	i69 & 70	i68	i69	i69
CAPACITY KG	3.5	7	12	25	5	10	15	5	10	15
OUTPUT KG PER HOUR	62.9	90	220	513.1	111	296	399	134	323	501
MOUNTING	Drainer or worktop	Drainer or worktop	Floor mounted	Floor mounted	Counter top	Floor standing	Floor standing	Counter top	Floor standing	Floor standing
PRODUCT USES										
PEELING POTATOES AND ROOT VEGETABLES	Potatoes only	Potatoes only	Potatoes only	Potatoes only	✓	✓	✓	✓	✓	✓
FINE FINISHING OF VEGETABLES	-	-	-	-	with optional knife plate	with optional knife plate	with optional knife plate	-	-	-
WASHING OF VEGETABLES	-	-	-	-	with optional vegetable washing plate	with optional vegetable washing plate	with optional vegetable washing plate	-	-	-
ONION/SHALLOT PEELING	-	-	-	-	with optional onion peeling plate	with optional onion peeling plate	with optional onion peeling plate	-	-	-
WASHING OF MUSSELS	-	-	-	-	with optional mussel washing plate	with optional mussel washing plate	with optional mussel washing plate	-	-	-
SPIN SALADS	-	-	-	-	with optional salad spinning basket	with optional salad spinning basket	with optional salad spinning basket	-	-	-
TIMER	Yes	Yes	Yes	Yes	Yes	Yes	Yes	Yes	Yes	Yes
PHASES AVAILABLE	Single or three	Single or three	Single or three	Single or three	Single	Single or three	Single or three	Single	Single or three	Single or three

Potato Chippers

	PC2	CS-C1
PAGE	i72	i73
HOPPER CAPACITY KG	12	12
OUTPUT KG PER MINUTE	25	25
MOUNTING	Drainer, worktop or optional stand	Drainer, worktop or optional stand
KNIFE BLOCK SIZES AVAILABLE	12mm, 14mm, 14mm x 14mm, 21mm x 17mm	12mm, 14mm, 14mm x 14mm, 21mm x 17mm
BUCKET SHELF ACCESSORY AVAILABLE	-	✓
POTATO TANK ACCESSORY AVAILABLE	-	✓
PHASES AVAILABLE	Single	Single

2 YEAR | UK parts and labour warranty | Export parts warranty
on all IMC products



VQ PEELER



In busy kitchens, staff need to be able to prepare potatoes quickly and efficiently. Save time and effort with a VQ peeler.

VQ peelers are compact and powerful, making them ideal for small to medium-sized kitchens where space is at a premium, but performance cannot be compromised.

Two sizes are available, which have the capacity to process vegetables in either 3.5kg or 7kg batches. The 3.5kg unit can process 62.9kg of potatoes per hour and the 7kg capacity unit - 90kg. VQ bench-top peelers have a small footprint and quiet running motor, enabling them to be used in the smallest of

kitchens. A heavy-duty belt and pulley system makes the peeler easy and safe to use.

Want to peel potatoes with speed? VQ peelers will produce high volumes from a small footprint.

Ideally suited for...



Fish and chip shops

Reduce customer waiting times by investing in speedy preparation equipment behind the scenes. A VQ peeler produces high volumes from a small footprint.



Pubs and restaurants

In busy kitchens, make food preparation quick and easy with a VQ peeler. Focus your efforts on cooking and serving.

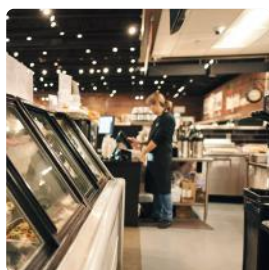

Fast food outlets

Serve food quickly by preparing potatoes ahead with a high output VQ peeler.

Benefits at a glance

- Able to peel potatoes at speed
- Small footprint
- Simple and safe to operate
- Easy to clean
- Robust construction



VQ 3.5 Potato Peeler

- Able to peel 62.9kg of vegetables per hour, in 3.5kg batches
- Small footprint and quiet operation, ideal for smaller kitchens
- Compact design for countertops and sink drainers
- Heavy-duty belt and pulley for simple and safe operation
- Self-draining cylinder with smooth profile for easy cleaning
- Long-lasting, rust-proof cast aluminium plate for effective peeling
- WRAS-approved Class A air-break and brass spray nozzle to prevent water escape



VQ 7 Potato Peeler

- Able to peel 90kg of vegetables per hour, in 7kg batches
- Small footprint and quiet operation, ideal for smaller kitchens
- Compact design for countertops and sink drainers
- Heavy-duty belt and pulley for simple and safe operation
- Self-draining cylinder with smooth profile for easy cleaning
- Long-lasting, rust-proof cast aluminium plate for effective peeling
- Class A air-break and brass spray nozzle to prevent water escape



VQ 3.5 Potato Peeler											
MODEL	PRICE £	PRICE €	DESCRIPTION	PHASE	H	W	D	POWER	CAPACITY	OUTPUT	WT
F72/200	£2313	€2659	VQ 3.5	1	425	653	367	0.18kW	3.5kg	63kg per hour	30.5

VQ 7 Potato Peeler											
MODEL	PRICE £	PRICE €	DESCRIPTION	PHASE	H	W	D	POWER	CAPACITY	OUTPUT	WT
F72/210	£2812	€3233	VQ 7	1	500	653	367	0.18kW	7kg	90kg per hour	31.5

Accessories

MODEL	PRICE £	PRICE €	DESCRIPTION
A E72/011	£139	€161	Sink Skip - Stainless steel, for use with bench mounted machines
A S72/220	£665	€765	Trolley - 890mm high
A S72/221	£542	€624	Pedestal - Lifts potato discharge height in steps to 750, 800, 850, 900 & 950mm
A S72/023	£409	€471	Waste Ejector - 2" BSP
A A29/003	£22	€25.35	Lid Retaining Strap - For marine use



E72/011



S72/220



S72/221

SP PEELER



SP peelers are amongst the fastest potato peelers on the market, helping you deliver through the busiest periods.

SP peelers make fresh potatoes as quick and easy to use as pre-prepared products. Their compact design ensures that even the 25kg model takes up a minimum amount of floor space. They are also safe and simple to use, and minimise staff labour.

Not only are these peelers the easiest and quickest to clean, they're also built to last, with exceptional durability and outstanding reliability. With a choice of pedestal heights, capacities and outputs, there's an SP Peeler to suit your working

environment. The thickly-gritted, non-rusting cast aluminium peeler plate is robust and offers a long service life. The hygienic brushed stainless steel finish is easy to wash, whilst the lid and peeling plate are quick and easy to remove for cleaning.

For high-speed peeling and high output, invest in a space-saving SP peeler.

Ideally suited for...



Fish and chip shops

Take the stress away from peak periods with an SP peeler - prepare high volumes of potatoes for chipping.



Pubs and restaurants

Keep up with demand at busy times with an SP peeler. Peel large quantities of potatoes in super quick time.

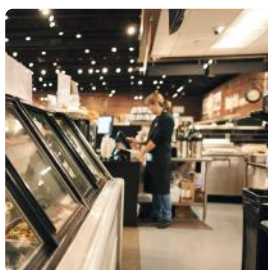

Fast food outlets

Where speed is crucial, accelerate your food preparation process with an SP potato peeler.

Benefits at a glance

- Able to peel high volumes of potatoes, fast
- Compact footprint
- Safe and simple to operate
- Long-lasting, robust construction
- Easy to maintain



SP12 Potato Peelers

- Able to peel 12kg of potatoes in 2 minutes - up to 220kg per hour
- Low pedestal version, the perfect height to empty into a sink
- Upright design with small footprint, ideal for medium and large operations
- Lubricated, heavy-duty gearbox makes peeling operation smooth and reliable
- Dual position waste outlets and smooth cylinder base for quick, easy cleaning
- Long-lasting, rust-proof plate and reversible liners for effective peeling
- WRAS-approved Class A air-break and brass spray nozzle to prevent water escape



Accessories

MODEL	PRICE £	PRICE €	DESCRIPTION
A S58/568	£580	€667	Integral Filter Basket
A S58/570	£473	€568	Waste Ejector (2" BSP)
A S58/569	£572	€658	Interceptor Tank (2" BSP)
A A29/003	£22	€25.35	Lid Retaining Strap

SP12H Potato Peelers

- Able to peel 12kg of potatoes in 2 minutes - up to 220kg per hour
- High pedestal version, the perfect height to empty into a mobile chip hopper
- Upright design with small footprint, ideal for medium and large operations.
- Lubricated, heavy-duty gearbox makes peeling operation smooth and reliable
- Dual position waste outlets and smooth cylinder base for quick, easy cleaning
- Long-lasting, rust-proof plate and reversible liners for effective peeling
- WRAS-approved Class A air-break and brass spray nozzle to prevent water escape



SP12 Potato Peeler											
MODEL	PRICE £	PRICE €	DESCRIPTION	PHASE	H	W	D	POWER	CAPACITY	OUTPUT	WT
F58/900	£4933	€5674	SP12 Low Pedestal	1	1109	530	624	370W	12kg	220kg per hour	58.5
*F58/901	£4769	€5484	SP12 Low Pedestal	3	1109	530	624	370W	12kg	220kg per hour	58.5

SP12H Potato Peeler											
MODEL	PRICE £	PRICE €	DESCRIPTION	PHASE	H	W	D	POWER	CAPACITY	OUTPUT	WT
F58/902	£5021	€5775	SP12H High Pedestal	1	1388	530	624	370W	12kg	220kg per hour	60.5
*F58/903	£4860	€5589	SP12H High Pedestal	3	1388	530	624	370W	12kg	220kg per hour	60.5

SP25 Potato Peelers

- 2 minutes to peel a 25 kilo bag - up to 513kg per hour
- Low pedestal version, the perfect height to empty into a sink
- Upright design with small footprint, ideal for medium and large operations
- Lubricated, heavy-duty gearbox makes peeling operation smooth and reliable
- Dual position waste outlets and smooth cylinder base for quick, easy cleaning
- Long-lasting, rust-proof plate and reversible liners for effective peeling
- Class A air-break and brass spray nozzle to prevent water escape



Accessories

MODEL	PRICE £	PRICE €	DESCRIPTION
A S58/568	£580	€667	Integral Filter Basket
A S58/570	£473	€568	Waste Ejector (2" BSP)
A S58/569	£572	€658	Interceptor Tank (2" BSP)
A A29/003	£22	€25.35	Lid Retaining Strap

SP25H Potato Peelers

- 2 minutes to peel a 25 kilo bag - up to 513kg per hour
- High pedestal version, the perfect height to empty into a mobile chip hopper
- Upright design with small footprint, ideal for medium and large operations
- Lubricated, heavy-duty gearbox makes peeling operation smooth and reliable
- Dual position waste outlets and smooth cylinder base for quick, easy cleaning
- Long-lasting, rust-proof plate and reversible liners for effective peeling
- Class A air-break and brass spray nozzle to prevent water escape



SP25 Potato Peeler											
MODEL	PRICE £	PRICE €	DESCRIPTION	PHASE	H	W	D	POWER	CAPACITY	OUTPUT	WT
F58/910	£6080	€6992	SP25 Low Pedestal	1	1057	602	727	750W	25kg	513kg per hour	78
*F58/911	£5870	€6750	SP25 Low Pedestal	3	1057	602	727	750W	25kg	513kg per hour	78

SP25H Potato Peeler											
MODEL	PRICE £	PRICE €	DESCRIPTION	PHASE	H	W	D	POWER	CAPACITY	OUTPUT	WT
F58/912	£6165	€7090	SP25H High Pedestal	1	1357	603	728	750W	25kg	513kg per hour	80.5
*F58/913	£5956	€6849	SP25H High Pedestal	3	1357	603	728	750W	25kg	513kg per hour	80.5

MF

MULTI-FUNCTIONAL
PEELER



Versatile and available in a range of sizes, MF peelers produce perfectly-prepared vegetables.

Offering a great deal more than just vegetable peeling, our MF models are essential all-rounders for any commercial kitchen. Designed to peel a full load of potatoes or other vegetables in little more than a minute, these versatile, highly-efficient units free up time for other preparation tasks.

The MF Range is available with a wide range of plates, each designed to perform a different function.

Practical features include a viewing panel to monitor progress, an interlocking lid for safe operation and an adjustable timer for repeatable, consistent results. In addition to the standard long-life peeling plate, options include a knife plate to give a smoother look to potatoes and carrots, whilst onions and shallots have their own special plate and liners. There's a washing plate for use with summer vegetables, as well as a plate for cleaning mussels and a salad spinning basket.

Ideally suited for...



Fish and chip shops

Want to save time on food preparation so you can serve more customers? A multi-functional MF peeler is the perfect partner for your kitchen.



Pubs and restaurants

Keep customers happy with high-quality food and great service. Speed up food preparation time with an MF peeler.



Fast food outlets

Satisfy customers with speedy service. Accelerate your food preparation process with an MF peeler.

Multi-functional and efficient, the MF range saves operators valuable time.

Benefits at a glance

- Versatile
- Cost effective
- Energy efficient
- Safe and simple to operate
- Easily adjustable timer
- Easy to maintain
- Built to last



MF5 Multifunctional Peeler

- Able to peel up to 111kg of vegetables per hour - in 5kg batches
- Versatile - can be used to peel and wash veg and mussels, and spin salad.
- Interlocking lid ensures safe operation
- Perspex viewing pane allows you to monitor the peeling progress
- Adjustable timer ensures accurate, repeatable peeling times
- Modular construction facilitates easy maintenance
- Thicker peeling plate delivers longer operating life



MF5L Multifunctional Peeler

- Able to peel up to 134kg of vegetables per hour - in 5kg batches
- With carborundum liner to reduce peeling time even further
- Interlocking lid ensures safe operation
- Perspex viewing pane allows you to monitor the peeling progress
- Adjustable timer ensures accurate, repeatable peeling times
- Modular construction facilitates easy maintenance
- Thicker peeling plate delivers longer operating life



MF5 Multifunctional Peeler											
MODEL	PRICE £	PRICE €	DESCRIPTION	PHASE	H	W	D	POWER	CAPACITY	OUTPUT	WT
*F59/500	£3289	€3782	MF5	1	634	366	519	0.25KW	5kg	111kg per hour	32

MF5L Multifunctional Peeler											
MODEL	PRICE £	PRICE €	DESCRIPTION	PHASE	H	W	D	POWER	CAPACITY	OUTPUT	WT
*F59/500/L	£3327	€3826	MF5L with Carborundum Liner	1	634	366	519	0.25KW	5kg	134kg per hour	33.5

Accessories

MODEL	PRICE £	PRICE €	DESCRIPTION
A S59/163	£252	€290	Additional Carborundum Peeling Plate
A S59/167	£372	€429	Knife Peeling Plate
A S59/174	£300	€344	Mussel Washing Plate
A S59/169	£347	€400	Salad Spinning Basket
A S59/325	£POA	€POA	Stand and Filter Basket

Accessories

MODEL	PRICE £	PRICE €	DESCRIPTION
A S59/163	£252	€290	Additional Carborundum Peeling Plate
A S59/325	£POA	€POA	Stand and Filter Basket



S59/325

MF10 Multifunctional Peeler

- Able to peel up to 296kg of vegetables per hour - in 10kg batches
- Versatile - can be used to peel and wash veg and mussels, and spin salad
- Interlocking lid ensures safe operation
- Perspex viewing pane allows you to monitor the peeling progress
- Adjustable timer ensures accurate, repeatable peeling times
- Modular construction facilitates easy maintenance
- Thicker peeling plate delivers longer operating life



MF10L Multifunctional Peeler

- Able to peel up to 323kg of vegetables per hour - in 10kg batches
- With carborundum liner to reduce peeling times even further
- Interlocking lid ensures safe operation
- Perspex viewing pane allows you to monitor the peeling progress
- Adjustable timer ensures accurate, repeatable peeling times
- Modular construction facilitates easy maintenance
- Thicker peeling plate delivers longer operating life



MF10 Multifunctional Peeler											
MODEL	PRICE £	PRICE €	DESCRIPTION	PHASE	H	W	D	POWER	CAPACITY	OUTPUT	WT
*F59/510	£5195	€5975	MF10	1	1105	481	633	370W	10kg	296kg per hour	59
*F59/511	£5007	€5759	MF10	3	1105	481	633	370W	10kg	296kg per hour	59

MF10L Multifunctional Peeler											
MODEL	PRICE £	PRICE €	DESCRIPTION	PHASE	H	W	D	POWER	CAPACITY	OUTPUT	WT
*F59/510/L	£5233	€6019	MF10L with Carborundum Liner	1	1105	481	633	370W	10kg	323kg per hour	60.5
*F59/511/L	£5046	€5804	MF10L with Carborundum Liner	3	1105	481	633	370W	10kg	323kg per hour	60.5

MF15 Multifunctional Peeler

- Able to peel up to 399kg of vegetables per hour - in 15kg batches
- Versatile - can be used to peel and wash veg and mussels, and spin salad
- Interlocking lid ensures safe operation
- Perspex viewing pane allows you to monitor the peeling progress
- Adjustable timer ensures accurate, repeatable peeling times
- Modular construction facilitates easy maintenance
- Thicker peeling plate delivers longer operating life



MF15L Multifunctional Peeler

- Able to peel up to 501kg of vegetables per hour - in 15kg batches
- With carborundum liner to reduce peeling times even further
- Interlocking lid ensures safe operation
- Perspex viewing pane allows you to monitor the peeling progress
- Adjustable timer ensures accurate, repeatable peeling times
- Modular construction facilitates easy maintenance
- Thicker peeling plate delivers longer operating life



MF15 Multifunctional Peeler											
MODEL	PRICE £	PRICE €	DESCRIPTION	PHASE	H	W	D	POWER	CAPACITY	OUTPUT	WT
*F59/520	£5870	€6750	MF15	1	1177	481	635	730W	15kg	399kg per hour	69.1
*F59/521	£5683	€6535	MF15	3	1177	481	635	600W	15kg	399kg per hour	69.1

MF15L Multifunctional Peeler											
MODEL	PRICE £	PRICE €	DESCRIPTION	PHASE	H	W	D	POWER	CAPACITY	OUTPUT	WT
*F59/520/L	£5907	€6793	MF15L with Carborundum Liner	1	1177	481	635	730W	15kg	510kg per hour	62.5
*F59/521/L	£5720	€6579	MF15L with Carborundum Liner	3	1177	481	635	600W	15kg	510kg per hour	62.5

Accessories

MODEL	PRICE £	PRICE €	DESCRIPTION
A S59/164	£320	€369	Additional Carborundum Peeling Plate
A S59/170	£380	€438	MF10 Salad Spinning Basket
A S59/171	£405	€466	MF15 Salad Spinning Basket
A S59/168	£559	€644	Knife Peeling Plate
A S59/173	£524	€603	Vegetable Washing Plate
A S59/175	£370	€425	Mussel Washing Plate
A E72/011	£139	€161	Potato Peeler Sink Skip
A S58/062	£43	€49	Potato Peeler Inlet Hose Kit
A S59/310	£POA	€POA	Stand and Filter Basket

Accessories

MODEL	PRICE £	PRICE €	DESCRIPTION
A S59/164	£320	€369	Additional Carborundum Peeling Plate
A E72/011	£139	€161	Potato Peeler Sink Skip
A S58/062	£43	€49	Potato Peeler Inlet Hose Kit
A S59/310	£POA	€POA	Stand and Filter Basket

* Please refer to page i99 for electricity supply requirements



MF10 Multifunctional Peeler with Onion Plate

- Able to peel up to 144kg of onions per hour - in 10kg batches
- Smooth stainless steel waste outlet prevents blockages and build-up of peelings
- Interlocking lid ensures safe operation
- Perspex viewing pane allows you to monitor the peeling progress
- Adjustable timer ensures accurate, repeatable peeling times
- Modular construction facilitates easy maintenance
- Thicker peeling plate delivers longer operating life



MF15 Multifunctional Peeler with Onion Plate

- Able to peel up to 202kg of onions per hour - in 15kg batches
- Smooth stainless steel waste outlet prevents blockages and build-up of peelings
- Interlocking lid ensures safe operation
- Perspex viewing pane allows you to monitor the peeling progress
- Adjustable timer ensures accurate, repeatable peeling times
- Modular construction facilitates easy maintenance
- Thicker peeling plate delivers longer operating life



MF10 Multifunctional Peeler with Onion Plate											
MODEL	PRICE £	PRICE €	DESCRIPTION	PHASE	H	W	D	POWER	CAPACITY	OUTPUT	WT
*F59/710	£5404	€6215	MF10 with Onion Plate	1	1105	481	629	730W	10kg	144kg per hour	60.5
*F59/720	£5164	€5939	MF10 with Onion Plate	3	1105	481	629	600W	10kg	144kg+g per hour	60.5

MF15 Multifunctional Peeler with Onion Plate											
MODEL	PRICE £	PRICE €	DESCRIPTION	PHASE	H	W	D	POWER	CAPACITY	OUTPUT	WT
*F59/730	£6075	€6987	MF15 with Onion Plate	1	1171	481	629	730W	15kg	202kg per hour	62.5
*F59/740	£5890	€6774	MF15 with Onion Plate	3	1171	481	629	600W	15kg	202kg per hour	62.5

Accessories for MF10/MF15 with Onion Plate

MODEL	PRICE £	PRICE €	DESCRIPTION
A S59/166	£298	€342	Additional Onion Peeling Plate
A S58/062	£43	€49	Inlet Hose Kit
A S59/315	£POA	€POA	Stand and Filter Basket

IMChip

Potato Chippers



Produce 25kg of chips per minute with the CS-C1 or PC2 chipper.

These flexible units can be mounted on a drainer, worktop or stand, making it the ideal solution for kitchens of any size. Screw-down, rigid knife blocks in four different sizes, provide the perfect cut every time, with minimal waste.

To cut chips to the perfect size and shape, IMChip chippers are supplied with a knife block in a size of your choice: 12mm, 14mm, 17mm by 14mm, or 21mm by 17mm. Its extra large hopper, with safety interlock makes for quick and easy loading, meaning potatoes can be loaded quickly and easily, so that kitchens can keep up with demand at busy times.

Ideally suited for...



Fish and chip shops

Take busy periods in your stride with an IMChip chipper, which can produce 25kg of perfectly chipped potatoes a minute.



Pubs and restaurants

Enhance the main event by serving perfectly-cut chips on the side. The IMChip chippers produce high volume, fast, to speed up serving times.



Fast food outlets

Service speed is crucial in a fast food restaurant. Shorten waiting times with an IMChip chipper, which can produce 25kg of chips in just one minute.

Need to produce a high volume of chips quickly? The IMChip chippers deliver 25kg a minute, saving kitchens valuable time.

Benefits at a glance

- High output - 25kg per minute
- Compact design
- Provides minimal waste
- Safe to operate
- Robustly engineered
- Easy to clean
- Easy to load



PC2 Potato Chipper

- Able to produce 25kg of chips per minute
- Compact design, with flexible mounting options, to suit kitchens of any size
- Large-capacity 12kg hopper allows quick and easy loading
- One-piece knife block design for quick and safe cutting, with minimal waste
- Supplied with knife block - 12mm, 14mm, 17mm, or 21mm sizes available
- Engineered using heavy-gauge stainless steel, for longevity and easy cleaning
- UK 3 pin plug allows users to simply plug in and switch on
- Please specify a knife block option at point of ordering chipper



PC2 Potato Chipper											
MODEL	PRICE £	PRICE €	DESCRIPTION	PHASE	H	W	D	POWER	CAPACITY	OUTPUT	WT
F61/220	£4659	€5358	PC2 Potato Chipper	1	550	370	603	340W	15kg	25kg per minute	46.5

Knife block options

Please specify at point of ordering chipper

MODEL	PRICE £	PRICE €	DESCRIPTION
0* S61/135	£371	€427	Knife block 12mm x 12mm
0* S61/114	£371	€427	Knife block 14mm x 14mm
0* S61/115	£371	€427	Knife block 17 x 14mm
0* S61/182	£371	€427	Knife block 21 x 17mm

Spares and Accessories

MODEL	PRICE £	PRICE €	DESCRIPTION
A S61/221	£354	€408	Chipper Stand
S S61/134	£145	€166.80	Replacement blades for 12mm x 12mm knife block (6 blades)
S S61/129	£104.95	€120.70	Replacement blades for 14mm x 14mm knife block (5 blades)
S S61/128	£104.95	€120.70	Replacement blades for 17mm x 14mm knife block (4 blades)
S S61/183	£104.95	€120.70	Replacement blades for 21mm x 17mm knife block (4 blades)



Knife Block

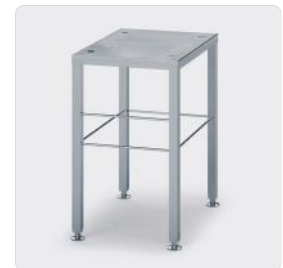

Chipper Stand

CS-C1 Potato Chipper

- Able to produce 25kg of chips per minute
- Compact design, with flexible mounting options, to suit kitchens of any size
- Screw-down, rigid knife block provides perfect cut every time with little waste
- Supplied with knife block - 12mm, 14mm, 17mm, or 21mm sizes available
- Extra large hopper, with safety interlock, allows quick and easy loading
- Safe, single blade design for quick removal and replacement
- Engineered using heavy-gauge stainless steel, for longevity and easy cleaning
- UK 3 pin plug allows users to simply plug in and switch on
- Please specify a knife block option at point of ordering chippers



CS-C1 Potato Chipper											
MODEL	PRICE £	PRICE €	DESCRIPTION	PHASE	H	W	D	POWER	CAPACITY	OUTPUT	WT
F61/301	£4379	€5035	CS-C1 Potato Chipper	1	550	400	692	340W	15kg	25kg per minute	46.5

Knife block options

Please specify at point of ordering chipper

MODEL	PRICE £	PRICE €	DESCRIPTION
0* S61/145	£317	€366	Knife block 12mm x 12mm
0* S61/151	£317	€366	Knife block 14mm x 14mm
0* S61/144	£317	€366	Knife block 17 x 14mm
0* S61/184	£317	€366	Knife block 21 x 17mm

Spare and Accessories

MODEL	PRICE £	PRICE €	DESCRIPTION
S S61/134	£145.05	€166.80	Replacement blades for 12mm x 12mm knife block (6 blades)
S S61/129	£104.95	€120.70	Replacement blades for 14mm x 14mm knife block (5 blades)
S S61/128	£104.95	€120.70	Replacement blades for 17mm x 14mm knife block (4 blades)
S S61/183	£104.95	€120.70	Replacement blades for 21mm x 17mm knife block (4 blades)
A S61/142	£233	€269	Bucket (solid)
A S61/143	£233	€269	Bucket (perforated)
A S61/141	£151	€172	Bucket shelf
A S61/221	£354	€408	Chipper Stand
A S61/171	£1990	€2289	Potato tank with eyeing tray - Low (approx 10 bags)
A S61/205	£2239	€2576	Mobile Potato tank with eyeing tray - Low (approx 10 bags)
A S61/170	£1990	€2289	Potato tank with eyeing tray (approx 10 bags)
A S61/204	£2239	€2576	Mobile Potato tank with eyeing tray (approx 10 bags)
A S61/167	£2096	€2411	Potato tank with eyeing tray (approx 12 bags)
A S61/203	£2342	€2694	Mobile Potato tank with eyeing tray (approx 12 bags)
A S61/169	£2370	€2726	Potato tank with eyeing tray (approx 14 bags)
A S61/202	£2445	€2813	Mobile Potato tank with eyeing tray (approx 14 bags)
A S61/166	£2283	€2624	Potato tank with eyeing tray (approx 18 bags)
A S61/201	£2529	€2908	Mobile Potato tank with eyeing tray (approx 18 bags)



Knife Block



Bucket Shelf

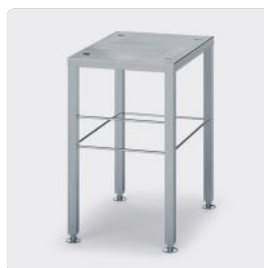

Chipper Stand

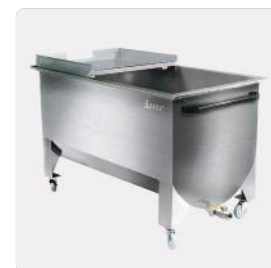

Potato Tank with eyeing tray





Waste Management

• Food Waste Disposers • Waste Compactors



Create a cleaner, safer working environment and save time and money, by investing in efficient waste management equipment.

From leftovers on a plate, to high volumes of packaging, we have a wide variety of solutions to handle both food and dry waste. Our range of equipment spans waste disposers and compactors, to suit operations large and small.

Waste disposers provide a fast and efficient way to process food waste,

to create a cleaner, safer working environment and save on waste handling time.

Waste compactors cut waste volumes, which saves valuable handling time and reduces collection costs. They help organisations improve recycling rates and save on storage space.

Ideally suited for...



Pubs & Bars

Make the management of waste quick and easy - saving valuable staff time that can be spent serving customers.



Nursing homes

Meet the best hygiene practices.

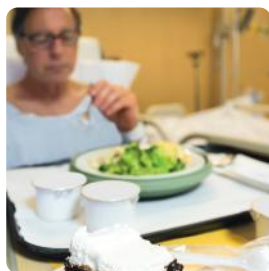

Hospitals

Handle high volumes of waste quickly, efficiently and cost-effectively.



Factories

Boost your recycling efforts and become greener by compacting your waste.

Make the management of waste quick and easy and saving valuable staff time.

Benefits at a glance

- Compact and efficient
- Remove waste quickly
- Safe and easy operation
- Reduces costs, saves time



Contents



WASTE STATION

Food Waste Management

Reducing the volume of food waste by up to 80% and the mass by up to 60%

Ideally suited for:

Restaurants, hospitals, care homes, schools, make the management of waste quick and easy.

Why choose WasteStation?

- Waste removal savings - reduce waste collection costs by up to 80%
- Reduce your carbon footprint - Lower frequency of vehicles collecting your waste
- Storage Savings - by reducing on site waste storage facility requirements
- Labour Savings - reduce staff time processing and managing waste
- Energy Savings - low operating costs and minimal use of kitchen floor space.
- Maximise Kitchen Hygiene
- Increases quality of dry recycling due to less contamination from food

Find out more on page

i77



Vulture

Compact Food Waste Disposers

Create a clean, safe working environment and save time and money

Ideally suited for:

Vulture food waste disposers provide a fast and efficient way to process food waste, making it perfect for a range of applications, such as pubs, restaurants, nursing homes and hospitals.

Why choose Vulture?

- Compact and efficient
- Remove waste quickly
- Safe and easy operation
- Reduces costs, saves time

Find out more on page

i83



IP COMPACTOR

Waste Compactors

Cut waste volumes by up to 80%

Ideally suited for:

Whether you are a small hotel, restaurant, large school, hospital, shop, factory or ship, handle high volumes of dry waste quickly, efficiently and cost-effectively with an IP compactor.

Why choose IP Compactor?

- Cut your waste volumes by up to 80%
- Cut your waste collection costs
- Designed to compress all dry waste, including cardboard, tins, plastic and paper
- Tough, reliable and simple to use
- Quiet, safe and energy efficient
- Avoid heavy lifting, models with trolley or bin to wheel to disposal point
- Minimise the area needed for waste storage

Find out more on page

i91

2
YEAR

UK parts and labour warranty

Export parts warranty

on all IMC products

All prices are exclusive of VAT.

UK

Goods are normally delivered free of charge to either the dealers' address or direct within 3 working days. If overnight and/or premium services are required charges will apply.

Export

Goods are priced ex works, export packaging is included.

☎ UK Tel: 01522 875500

☎ Export Tel: +44 1522 503250

✉ UK e-mail: sales@lincat.co.uk

✉ Export e-mail: export@lincat.co.uk



WASTE STATION



Food waste typically represents around 40% of total commercial catering waste. It is difficult and costly to process and dispose of this efficiently.

Of this 40%, approximately 77% is liquid. WasteStation grinds the food waste into fine particles, which are fed directly into a built-in dewatering system, or for where space in the kitchen is limited, a remote dewatering system. Through centrifugal action, excess liquid is forced out.

The resulting solid fraction of the food waste is collected in small, easily managed, lidded bins, ready for onward processing.

Ideally suited for...



Restaurants

Make the management of waste quick and easy - saving valuable staff time that can be spent serving customers.



Care homes

Meet the best hygiene practices

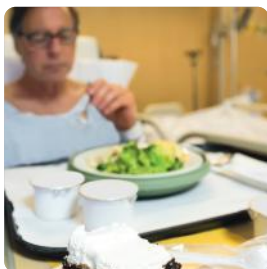

Hospitals

Waste Station can handle high volumes of waste quickly, efficiently and cost-effectively.



Schools

With the WasteStation and WasteStation compact, we have a waste solution whatever the size of your school.

WasteStation reduces the volume of food waste by up to 80% and the mass by up to 60%

Benefits at a glance

- Waste removal savings - reduce waste collection costs by up to 80%
- Reduce your carbon footprint - Lower frequency of vehicles collecting your waste
- Storage Savings - by reducing on site waste storage facility requirements
- Labour Savings - reduce staff time processing and managing waste
- Energy Savings - low operating costs and minimal use of kitchen floor space.
- Maximise Kitchen Hygiene
- Increases quality of dry recycling due to less contamination from food



Food Waste Management



WasteStation

Page i80

Reliable and efficient, the WasteStation allows staff to quickly reduce the volume of food waste, making it ideal for a wide range of applications including hotels, restaurants, hospitals, canteens, and prisons processing up to 1450 covers per hour.

The macerator and dewaterer reduce the waste volume by up to 80%, reducing on site storage as well as waste collection costs.

WasteStation Compact 2

Page i80

Compact and space saving the WasteStation Compact offers establishments of up to 850 covers the same benefits as the WasteStation for plate and medium food waste, all within a 40% smaller footprint. Single or 3 phase version available.

Ideal for small to medium size hotels, restaurants, nursing homes and schools.





WastePro II

Page i82

The flexibility of WastePro II provides a cost effective system for commercial and institutional kitchens. Connected to a suitable existing IMC or alternative brand waste disposer in either a standalone or trough configuration WastePro II removes excess liquid from macerated food waste through centrifugal action, reducing the volume of waste by up to 80%.

Food Waste Disposers			
	WasteStation Compact 2	WasteStation	WastePro II
PAGE	i80	i80	i82
PRODUCT CODE	F79/701 (1ph) F79/703 (3ph)	F79/010 (3ph)	F78/020 (Right hand discharge) F78/030 (Left hand discharge)
COVERS	850	1450	1850
WASTE PER HOUR (KG)	400	700	900
LOADING	Bucket Feed	Bucket Feed	N/A
MACERATOR	Within unit	Within unit	N/A
DEWATERER	Within unit	Within unit	Within unit
PUMPING DISTANCE (METRES)	N/A	N/A	55
SOFT WASTE (PLATE WASTE, VEG PEELINGS, MEAT AND FISH SCRAPS)	✓	✓	N/A
MEDIUM WASTE (SMALL PORK BONE AND CHICKEN BONES, VEGETABLES AND FRUIT)	✓	✓	N/A
TOUGH WASTE (ALL RED MEAT BONES, CAULIFLOWER STALKS AND FISH SKINS)	X	✓	N/A



WASTE STATION

80% reduction in waste - for every 5 wheelie bins you would normally fill with food waste, fill just 1!



Food waste typically represents around 40% of total commercial catering waste. Of this 40%, approximately 77% is liquid. WasteStation grinds the food waste into fine particles, these particles feed directly into the built-in dewatering system. Through centrifugal action, the WasteStation forces out the excess liquid from the macerated waste.

This "grey water" is fed directly to drain, the resulting solid fraction of the food waste is collected in small, easily managed, lidded bins, ready for onward processing.

Transport Savings

- Reduce waste collection costs by up to 80%.

Storage Savings

- By reducing the waste volume, on site waste storage facility requirements are also reduced.

Labour Savings

- Reduce staff time processing and managing waste. No loading schedule, process waste as and when you need to.
- Self-cleaning operation - WasteStation can undertake a thorough clean ensuring the whole system is free of food and grease.
- Self-emptying - this eliminates the need for staff to empty the auger assembly reducing labour. The intelligent electronic sensor, detects when the bin is full.
- Visual control panel - kitchens are a noisy environment, WasteStation incorporates a simple LED display to allow monitoring of the equipment during operation.

Energy Savings

- Compact design and short processing times ensure low operating costs and minimal use of kitchen floor space.

Maximising Kitchen Hygiene

- Self-rinse system - following each operation the machine undertakes a quick rinse cycle preventing any build-up of food and the associated odour.
- Fully enclosed system - prevents food entering the unit, keeping the machine clean and free of waste and reducing operational noise.

Ideally suited for

There is a WasteStation to suit the scale of your operation from WasteStation Compact 2 for organisations producing up to 400 kg waste per hour, 850 covers to the larger WasteStation for organisations producing up to 700 kg waste per hour, 1450 covers.

- Hotels
- Restaurants
- Supermarkets
- Schools
- Hospitals
- Canteens
- Refectories
- Prisons and barracks



WasteStation Compact 2



Introducing the next generation of the Waststation Compact

At 900mm high, 600mm wide and 700mm deep the Waststation Compact 2 is barely any larger than a standard undercounter fridge!

Ideal for small to medium size hotels, restaurants, nursing homes and schools.

Lincat

WasteStation and WasteStation Compact 2											
MODEL	PRICE £	PRICE €	DESCRIPTION	POWER	PHASE	H	W	D	WASTE PER HR	COVERS PER HR	WT
*F79/701	£18,150	€20,873	WasteStation Compact 2	2.95kW	1	1044	600	700	400 kg	850	182
*F79/703	£18,150	€20,873	WasteStation Compact 2	2.95kW	3	1044	600	700	400 kg	850	182

Accessories, Spares and Options for WasteStation Compact 2

MODEL	PRICE £	PRICE €	DESCRIPTION
A K12/469	£76	€87	Caddy
S A13/159	£30.05	€34.55	Scraper



WasteStation

Reliable and efficient the Waststation allows staff to quickly reduce the volume of food waste making it ideal for a wide range of applications including hotels, canteens and prisons



Lincat

WasteStation and WasteStation Compact 2											
MODEL	PRICE £	PRICE €	DESCRIPTION	POWER	PHASE	H	W	D	WASTE PER HR	COVERS PER HR	WT
*F79/010	£27,698	€31,854	WasteStation	4.1kW	3	900	1000	700	700 kg	1450	280
e *F79/100	£27,409	€31,521	WasteStation without air break	4.1kW	3	900	1000	700	700 kg	1450	280

Accessories, Spares and Options for WasteStation

MODEL	PRICE £	PRICE €	DESCRIPTION
A K12/357	£76	€87	Caddy
S A13/125	£70.55	€81.10	Scraper
0 VS605	£538	€618	Silver Saver Baffle



imc

lincat.co.uk

2026

WASTE STATION

WastePro II



Connected to a suitable existing IMC or alternative brand waster disposer in either a standalone or trough configuration WastePro II removes excess liquid from macerated food waste through centrifugal action, reducing the volume of waste by up to 80%.

WastePro II is ideal in instances where food waste can no longer be disposed of via mains drainage, either due to technical restrictions or legal regulations. The grey water is dispensed direct to drain whilst the solid waste is captured in a lidded bin for subsequent onward processing. The flexibility of WastePro II provides a cost effective system for commercial and institutional kitchens.



Features and Benefits

No need to replace existing waste disposer

- Simply connect to existing waster disposer in either a standalone or trough configuration
- Minimal disruption to kitchen

Ensures compliance with technical and legal restrictions

- Where food waste cannot be disposed of via mains drainage

Ideally suited for

- Kitchens with an existing waste disposer
- Where food waste cannot be disposed of via mains drainage either due to technical restrictions or legal regulations
- Cost-effective system for almost all commercial and institutional organisations

WasteStation CR												
MODEL	PRICE £	PRICE €	DESCRIPTION	POWER	PHASE	H	W	D	WASTE PER HR	COVERS PER HR	WT	
*F78/020	£15,725	€18,084	WastePro II Right hand discharge	1.1kW	3	980	450	825	900 kg	1950	130	
*F78/030	£15,725	€18,084	WastePro II Left hand discharge	1.1kW	3	980	450	825	900 kg	1950	130	

Accessories

MODEL	PRICE £	PRICE €	DESCRIPTION
A K12/357	£76	€87	Waste Caddy

* Please refer to page i99 for electricity supply requirements



Create a cleaner, safer working environment and save time and money, by investing in efficient waste disposal equipment.

With a compact design, 700 series waste disposers offer an excellent solution for the disposal of medium waste - small pork and chicken bones, vegetables and fruit.

800 series, 04 and 04X series food waste disposers offer quick and easy removal of high quantities of tough food waste, including red meat bones, cauliflower stalks and fish skins.

Ideally suited for...

Vulture food waste disposers provide a fast and efficient way to process food waste, making it perfect for a range of applications, such as:



Pubs & bars

Make the management of waste quick and easy - saving valuable staff time that can be spent serving customers.



Nursing homes

Meet the best hygiene practices



Hospitals

Handle high volumes of waste quickly, efficiently and cost-effectively.

Waste disposers provide a fast and efficient way to process food waste, to create a cleaner, safer working environment and save on waste handling time.

Benefits at a glance

- Compact and efficient
- Remove waste quickly
- Safe and easy operation
- Reduces costs, saves time



Food Waste Disposers

700 Series

Page i86

700 series food waste disposers allow small to medium-sized kitchens to remove waste quickly and efficiently, making them perfect for hotels, restaurants, schools and hospitals.

With a compact design, 700 series waste disposers offer an excellent solution for the disposal of medium waste - small pork and chicken bones, vegetables and fruit. A range of mounting options can be specified to suit each outlet, making the unit quick and easy to load, saving staff time.



800 Series

Page i87

Fast and powerful, 800 series food waste disposers provide the perfect solution for large catering operations, such as larger hotels, hospitals, universities and prisons, plus food preparation companies.

800 series food waste disposers offer excellent throughput and reliable performance with low operating costs. They allow the quick and easy removal of high quantities of tough food waste, including red meat bones, cauliflower stalks and fish skins. A range of mounting options can be specified to suit each outlet, making the unit quick and easy to load, saving staff time and labour.



04 & 04X Series

Page i88/i89

Reliable, efficient, safe and easy to operate, 04 and 04X waste disposers allow large operators to process heavy-duty food waste, quickly and efficiently.

Designed for use in large hotels and restaurants, hospitals, prisons, universities and by food preparation companies, 04 series waste disposers can handle medium to tough waste including fish skins, cauliflower stalks and larger meat bones. A range of mounting and hopper rim options can be specified to suit each outlet, making the unit quick and easy to load, saving time and energy.



Food Waste Disposers

	723	725	726	904	904X	825	826	1204	1204X	1604	1604X
PAGE	i86	i86	i86	i88	i89	i87	i87	i88	i89	i88	i89
COVERS PER SITTING	400	850	850	1000	1000	1350	1350	1450	1450	1850	1850
WASTE PER HOUR KG	250	400	400	500	500	600	600	700	700	900	900
MOUNTING	Undersink	In tabling	Free standing	Floor mounted, can be mounted in	Floor mounted, can be mounted in	In tabling	Free standing	Floor mounted, can be mounted in	Floor mounted, can be mounted in	Floor mounted, can be mounted in	Floor mounted, can be mounted in
SOFT WASTE (PLATE WASTE, VEG, PEELINGS, MEAT AND FISH SCRAPS)	✓	✓	✓	✓	✓	✓	✓	✓	✓	✓	✓
MEDIUM WASTE (SMALL PORK AND CHICKEN BONES, VEGETABLES AND FRUIT)	✓	✓	✓	✓	✓	✓	✓	✓	✓	✓	✓
TOUGH WASTE (ALL RED MEAT BONES, CAULIFLOWER STALKS, FISH SKINS)	-	-	-	-	-	✓	✓	✓	✓	✓	✓
PHASES AVAILABLE	Single or three	Single or three	Single or three	Single or three	Single or three	Three	Three	Three	Three	Three	Three



Vulture 700 Series



723 Food Waste Disposers

- Fast and efficient disposal of up to 250 kg/hour
- Handles up to 400 covers per sitting - ideal for medium-size kitchens
- Under Sink mounted
- For medium waste (small pork and chicken bones, vegetables and fruit)
- Manually reversible motor to extend operational life



723 Food Waste Disposers															
MODEL	PRICE £	PRICE €	DESCRIPTION	PHASE	WIRE	AIR BREAK	MOUNTING	H	W	D	SINK OPENING	POWER	WASTE PER HR	COVERS PER HR	WT
* F60/305	£4465	€5136	723	1	-	No	Undersink	573	218	304	90*	1.1kW	200kg	400	33
* F60/310	£4167	€4793	723	3	4	No	Undersink	573	218	304	90*	1.1kW	200kg	400	33

725 Food Waste Disposers

- Fast and efficient disposal of up to 400kg of food waste per hour
- Handles up to 850 covers per sitting - ideal for medium-size kitchens
- For medium waste (small pork and chicken bones, vegetables and fruit)
- Compact design allows hopper to be table-mounted, for quick and easy loading
- Manually reversible motor to extend operational life
- Available with a class A airbreak kit, recommended for when connecting to a mains water supply



With Airbreak



725 Food Waste Disposers														
MODEL	PRICE £	PRICE €	DESCRIPTION	PHASE	WIRE	AIR BREAK	MOUNTING	H	W	D	POWER	WASTE PER HR	COVERS PER HR	WT
* F60/100	£5389	€6198	725	1	-	No	In tabling	733	340	472	1.1kW	400kg	850	48
* F60/500	£6308	€7255	725	1	-	Yes	In tabling	853	340	472	1.1kW	400kg	850	48
* F60/121	£5092	€5856	725	3	4	No	In tabling	733	340	472	1.1kW	400kg	850	48
* F60/444	£5958	€6852	725	3	4	Yes	In tabling	853	340	472	1.1kW	400kg	850	48
* F60/120	£5092	€5856	725	3	5	No	In tabling	733	340	472	1.1kW	400kg	850	48
* F60/515	£5958	€6852	725	3	5	Yes	In tabling	853	340	472	1.1kW	400kg	850	48

MODEL	PRICE £	PRICE €	DESCRIPTION
0* VS355	£346	€399	Water Flow Control
0* VS167	£306	€351	Magnetic Cutlery Saver

726 Food Waste Disposers

- Fast and efficient disposal of up to 400kg of food waste per hour
- Handles up to 850 covers per sitting - ideal for medium-size kitchens
- For medium waste (small pork and chicken bones, vegetables and fruit)
- Free Standing
- Manually reversible motor to extend operational life
- Available with a class A airbreak kit, recommended for when connecting to a mains water supply



With Airbreak



726 Food Waste Disposers														
MODEL	PRICE £	PRICE €	DESCRIPTION	PHASE	WIRE	AIR BREAK	MOUNTING	H	W	D	POWER	WASTE PER HR	COVERS PER HR	WT
* F60/200	£6046	€6953	726	1	-	No	Free standing	850	400	600	1.1kW	400kg	850	55
* F60/555	£7075	€8136	726	1	-	Yes	Free standing	969	400	600	1.1kW	400kg	850	55
* F60/221	£5744	€6606	726	3	4	No	Free standing	850	400	600	1.1kW	400kg	850	55
* F60/404	£6721	€7729	726	3	4	Yes	Free standing	969	400	600	1.1kW	400kg	850	55
* F60/220	£5744	€6606	726	3	5	No	Free standing	850	400	600	1.1kW	400kg	850	55
* F60/505	£6721	€7729	726	3	5	Yes	Free standing	969	400	600	1.1kW	400kg	850	55

MODEL	PRICE £	PRICE €	DESCRIPTION
0* VS352	£346	€399	Water Flow Control
0* E60/010	£134	€155	Side Panel
0* VS167	£306	€351	Magnetic Cutlery Saver

0* Factory fitted option please request at point of ordering

* Please refer to page i99 for electricity supply requirements



825 Food Waste Disposers

- Fast and efficient disposal of up to 600kg of food waste per hour
- Handles up to 1350 covers per sitting - ideal for large size kitchens
- Under sink mounted
- Efficient disposal of tough waste (red meat bones, cauliflower stalks and fish skins)
- Manually reversible motor to extend operational life
- Available with a class A airbreak kit, recommended for when connecting to a mains water supply



With Airbreak



825 Food Waste Disposers														
MODEL	PRICE £	PRICE €	DESCRIPTION	PHASE	WIRE	AIR BREAK	MOUNTING	H	W	D	POWER	WASTE PER HR	COVERS PER HR	WT
* F68/121	£9576	€11,013	825	3	4	No	In tabling	783	360	530	2.2kW	600kg	1350	59
* F68/324	£9716	€11,173	825	3	4	Yes	In tabling	919	360	530	2.2kW	600kg	1350	59
* F68/120	£9576	€11,013	825	3	5	No	In tabling	783	360	530	2.2kW	600kg	1350	59
* F68/325	£9716	€11,173	825	3	5	Yes	In tabling	919	360	530	2.2kW	600kg	1350	59

MODEL	PRICE £	PRICE €	DESCRIPTION
0* VS357	£346	€399	Water Flow Control
0* VS167	£306	€351	Magnetic Cutlery Saver

826 Food Waste Disposers

- Fast and efficient disposal of up to 600kg of food waste per hour
- Handles up to 1350 covers per sitting - ideal for large size kitchens
- Efficient disposal of tough waste (red meat bones, cauliflower stalks and fish skins)
- Free Standing
- Manually reversible motor to extend operational life
- Available with a class A airbreak kit, recommended for when connecting to a mains water supply



With Airbreak



826 Food Waste Disposers														
MODEL	PRICE £	PRICE €	DESCRIPTION	PHASE	WIRE	AIR BREAK	MOUNTING	H	W	D	POWER	WASTE PER HR	COVERS PER HR	WT
* F68/221	£10,541	€12,123	826	3	4	No	Free standing	850	430	600	2.2kW	600kg	1350	73
* F68/326	£10,683	€12,285	826	3	4	Yes	Free standing	980	430	600	2.2kW	600kg	1350	73
* F68/220	£10,541	€12,123	826	3	5	No	Free standing	850	430	600	2.2kW	600kg	1350	73
* F68/327	£10,683	€12,285	826	3	5	Yes	Free standing	980	430	600	2.2kW	600kg	1350	73

MODEL	PRICE £	PRICE €	DESCRIPTION
0* VS358	£346	€399	Water Flow Control
0* E68/013	£134	€155	Side Panel
0* VS167	£306	€351	Magnetic Cutlery Saver
0* VS258	£341	€393	Remote Control Box



904 Food Waste Disposers

- Fast and efficient disposal of up to 500kg of food waste per hour
- Handles up to 1000 covers per sitting - ideal for medium-large size kitchens
- Efficient disposal of medium waste (small pork and chicken bones, vegetables and fruit)
- Floor mounted†
- Manually reversible motor for extended operational life
- Available with a with class A airbreak kit, recommended for when connecting to a mains water supply



904 Food Waste Disposers														
MODEL	PRICE £	PRICE €	DESCRIPTION	PHASE	WIRE	AIR BREAK	MOUNTING	H	W	D	POWER	WASTE PER HR	COVERS PER HR	WT
*F54/100	£9997	€11,496	904	1	-	No	Floor mounted†	800-905	438	564	1.1kW	500kg	1000	60
*F54/730	£10,139	€11,661	904	1	-	Yes	Floor mounted†	942-1047	438	564	1.1kW	500kg	1000	60
*F54/120	£9633	€11,078	904	3	4	No	Floor mounted†	800-905	438	564	1.1kW	500kg	1000	60
*F54/731	£9777	€11,244	904	3	4	Yes	Floor mounted†	942-1047	438	564	1.1kW	500kg	1000	60

†Can be welded into tabling with optional hopper rim accessory

MODEL	PRICE £	PRICE €	DESCRIPTION
A E30/095	£226	€260	Hopper rim
0* VS353	£351	€405	Water flow control
0* VS167	£306	€351	Magnetic cutlery saver
0* S55/016	£348	€401	Remote button box

1204 Food Waste Disposers

- Fast and efficient disposal of up to 600kg of food waste per hour
- Handles up to 1450 covers per sitting - ideal for large size kitchens
- Efficient disposal of tough waste (red meat bones, cauliflower stalks and fish skins)
- Floor mounted†
- Manually reversible motor for extended operational life
- Available with a with class A airbreak kit, recommended for when connecting to a mains water supply



1204 Food Waste Disposers														
MODEL	PRICE £	PRICE €	DESCRIPTION	PHASE	WIRE	AIR BREAK	MOUNTING	H	W	D	POWER	WASTE PER HR	COVERS PER HR	WT
*F54/220	£12,821	€14,744	1204	3	4	No	Floor mounted†	850-900	514	740	2.2kW	700kg	1450	84
*F54/724	£12,963	€14,908	1204	3	4	Yes	Floor mounted†	1014-1064	514	740	2.2kW	700kg	1450	84

†Can be welded into tabling with optional hopper rim accessory

MODEL	PRICE £	PRICE €	DESCRIPTION
A E30/096	£247	€284	Hopper rim
0* VS356	£351	€405	Water flow control
0* VS279	£621	€716	Magnetic cutlery saver
0* S55/016	£348	€401	Remote button box

1604 Food Waste Disposers

- Fast and efficient disposal of up to 900kg of food waste per hour
- Handles up to 1850 covers per sitting - ideal for large size kitchens
- Efficient disposal of tough waste (red meat bones, cauliflower stalks and fish skins)
- Floor mounted†
- Manually reversible motor for extended operational life
- Available with a with class A airbreak kit, recommended for when connecting to a mains water supply



1604 Food Waste Disposers														
MODEL	PRICE £	PRICE €	DESCRIPTION	PHASE	WIRE	AIR BREAK	MOUNTING	H	W	D	POWER	WASTE PER HR	COVERS PER HR	WT
*F54/320	£14,154	€16,278	1604	3	4	No	Floor mounted†	850-900	514	740	4kW	900kg	1850	93
*F54/727	£14,299	€16,444	1604	3	4	Yes	Floor mounted†	1014-1064	514	740	4kW	900kg	1850	93

†Can be welded into tabling with optional hopper rim accessory

MODEL	PRICE £	PRICE €	DESCRIPTION
A E30/096	£247	€284	Hopper rim
0* VS356	£351	€405	Water flow control
0* VS279	£621	€716	Magnetic cutlery saver
0* S55/016	£348	€401	Remote button box

0* Factory fitted option please request at point of ordering

* Please refer to page i99 for electricity supply requirements



Vulture 04X Series

904X Food Waste Disposers

- Fast and efficient disposal of up to 500kg of food waste per hour
- Handles up to 1000 covers per sitting - ideal for medium-large size kitchens
- Efficient disposal of medium waste (small pork and chicken bones, vegetables and fruit)
- Floor mounted†
- Manually reversible motor for extended operational life
- Low-load cut-outs ensure energy and water efficiency
- Available with a with class A airbreak kit, recommended for when connecting to a mains water supply

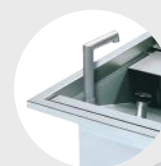

With Airbreak



904X Food Waste Disposers														
MODEL	PRICE £	PRICE €	DESCRIPTION	PHASE	WIRE	AIR BREAK	MOUNTING	H	W	D	POWER	WASTE PER HR	COVERS PER HR	WT
* F54/500	£10,670	€12,271	904X	1	-	No	Floor mounted†	800-905	438	564	1.1kW	500kg	1000	60
* F54/732	£10,814	€12,436	904X	1	-	Yes	Floor mounted†	942-1047	438	564	1.1kW	500kg	1000	60
* F54/520	£10,292	€11,836	904X	3	4	No	Floor mounted†	800-905	438	564	1.1kW	500kg	1000	60
* F54/733	£10,436	€12,002	904X	3	4	Yes	Floor mounted†	942-1047	438	564	1.1kW	500kg	1000	60
* F54/521	£10,292	€11,836	904X	3	5	No	Floor mounted†	800-905	438	564	1.1kW	500kg	1000	60
* F54/734	£10,436	€12,002	904X	3	5	Yes	Floor mounted†	942-1047	438	564	1.1kW	500kg	1000	60

†Can be welded into tabling with optional hopper rim accessory

MODEL	PRICE £	PRICE €	DESCRIPTION
A E30/095	£226	€260	Hopper rim
0* VS167	£306	€351	Magnetic Cutlery Saver
0* S54/026	£348	€401	Remote button box

1204X Food Waste Disposers

- Fast and efficient disposal of up to 600kg of food waste per hour
- Handles up to 1450 covers per sitting - ideal for large size kitchens
- Efficient disposal of tough waste (red meat bones, cauliflower stalks and fish skins)
- Floor mounted†
- Manually reversible motor for extended operational life
- Low-load cut-outs ensure energy and water efficiency
- Available with a with class A airbreak kit, recommended for when connecting to a mains water supply



With Airbreak



1204X Food Waste Disposers														
MODEL	PRICE £	PRICE €	DESCRIPTION	PHASE	WIRE	AIR BREAK	MOUNTING	H	W	D	POWER	WASTE PER HR	COVERS PER HR	WT
* F54/621	£13,498	€15,523	1204X	3	4	No	Floor mounted†	850-900	514	740	2.2kW	700kg	1450	84
* F54/725	£15,687	€16,308	1204X	3	4	Yes	Floor mounted†	1014-1064	514	740	2.2kW	700kg	1450	84
* F54/620	£13,498	€15,523	1204X	3	5	No	Floor mounted†	850-900	514	740	2.2kW	700kg	1450	84
* F54/726	£13,687	€16,308	1204X	3	5	Yes	Floor mounted†	1014-1064	514	740	2.2kW	700kg	1450	84

†Can be welded into tabling with optional hopper rim accessory

MODEL	PRICE £	PRICE €	DESCRIPTION
A E30/096	£247	€284	Hopper rim
0* VS356	£351	€405	Water flow control
0* VS279	£621	€716	Magnetic cutlery saver
0* S54/026	£348	€401	Remote button box

1604X Food Waste Disposers

- Fast and efficient disposal of up to 900kg of food waste per hour
- Handles up to 1850 covers per sitting - ideal for large size kitchens
- Efficient disposal of tough waste (red meat bones, cauliflower stalks and fish skins)
- Floor mounted†
- Manually reversible motor for extended operational life
- Low-load cut-outs ensure energy and water efficiency
- Available with a with class A airbreak kit, recommended for when connecting to a mains water supply



With Airbreak



1604X Food Waste Disposers														
MODEL	PRICE £	PRICE €	DESCRIPTION	PHASE	WIRE	AIR BREAK	MOUNTING	H	W	D	POWER	WASTE PER HR	COVERS PER HR	WT
* F54/721	£14,833	€17,057	1604X	3	4	No	Floor mounted†	850-900	514	740	4kW	900kg	1850	93
* F54/728	£14,977	€17,224	1604X	3	4	Yes	Floor mounted†	1014-1064	514	740	4kW	900kg	1850	93
* F54/720	£14,833	€17,057	1604X	3	5	No	Floor mounted†	850-900	514	740	4kW	900kg	1850	93
* F54/729	£14,977	€17,224	1604X	3	5	Yes	Floor mounted†	1014-1064	514	740	4kW	900kg	1850	93

†Can be welded into tabling with optional hopper rim accessory

MODEL	PRICE £	PRICE €	DESCRIPTION
A E30/096	£247	€284	Hopper rim
0* VS356	£351	€405	Water flow control
0* VS279	£621	€716	Magnetic cutlery saver
0* S54/026	£348	€401	Remote button box

0* Factory fitted option please request at point of ordering

* Please refer to page i99 for electricity supply requirements



IP COMPACTOR



Cut waste volumes by up to 80% with an IP Compactor.

Designed to compress all dry waste, including cardboard, tins, plastic and paper, our range of IP Compactors are tough, reliable and simple to use.

The IP waste compactor range has been developed to meet the needs of almost every application, from small hotels and restaurants to large schools, hospitals, shops, factories and ships. IP Compactors will give you a fast return on your investment, help you to improve hygiene standards and minimise the area needed for waste storage.

Manufactured from stainless steel, they are quick and easy to clean. Each incorporates proven electro-hydraulic technology to ensure that waste is compacted in seconds. Quiet, safe and energy efficient, IP Compactors operate from a standard 13 amp plug.

Our units are compact, easy to use and mounted on heavy duty casters or deck feet, so they can be located wherever waste is produced. Waste is fed via a loading chute into an integral trolley, lined with a tough, sealable plastic bag. In the case of the larger model, it is fed directly into standard 240-litre wheeled bins.

Ideally suited for...

Compress all dry waste in one compact unit. IP Compactors are suitable for:



Hotels and restaurants

Save valuable staff time and cut collection costs with a powerful waste compactor. IP Compactors can help streamline your waste management processes.

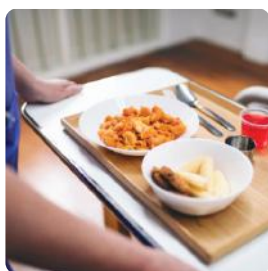

Hospitals

Handle high volumes of waste quickly, efficiently and cost-effectively with a waste compactor.

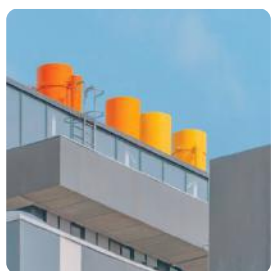

Factories

Boost your recycling efforts and become greener by compacting your waste. IP Compactors can help deliver cost savings and reduce staff labour.

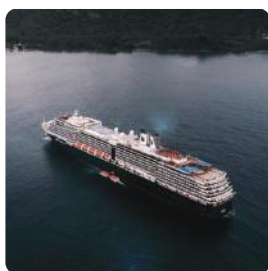

Ships

Need to handle high volumes of waste from on-board retail and leisure outlets, and passengers? Let our IP Compactor solve the problem - whilst saving you time and money.

Boost your recycling efforts with a an IP Compactor.

Benefits at a glance

- Cut your waste volumes by up to 80%
- Designed to compress all dry waste, including cardboard, tins, plastic and paper
- Tough, reliable and simple to use
- Quiet, safe and energy efficient
- Avoid heavy lifting, models with trolley or bin to wheel to disposal point
- Minimise the area needed for waste storage

IP COMPACTOR

IP400 Waste Compactor

- Small to large applications
- Cuts waste volumes by up to 80% and lowers waste handling and collection costs
- Compresses all dry waste - cardboard, tins, plastic and paper
- Powerful electro-hydraulic technology enables waste to be compacted in seconds
- Compact, easy-to-move unit can be conveniently located where waste is produced
- Manufactured from stainless steel making it tough, reliable and easy to clean
- UK 3 pin plug allows users to simply plug in and switch on



IP500 Waste Compactor

- Small to large applications
- Cuts waste volumes by up to 80% and lowers waste handling and collection costs
- Compresses all dry waste - cardboard, tins, plastic and paper
- Powerful electro-hydraulic technology enables waste to be compacted in seconds
- Compact, easy-to-move unit can be conveniently located where waste is produced
- Manufactured from stainless steel making it tough, reliable and easy to clean
- UK 3 pin plug allows users to simply plug in and switch on



Lincat

IP400 Waste Compactor											
MODEL	PRICE £	PRICE €	DESCRIPTION	H	W	D	POWER	STORAGE CAPACITY	EQUIVALENT UNCRUSHED	COMPACTION RATIO	WT
F56/400	£15,856	€18,234	IP400	1645	580	566	750W	55L	275L	5:1	242.5

IP500 Waste Compactor											
MODEL	PRICE £	PRICE €	DESCRIPTION	H	W	D	POWER	STORAGE CAPACITY	EQUIVALENT UNCRUSHED	COMPACTION RATIO	WT
F56/500	£17,577	€20,214	IP500	1740	678	675	750W	110L	550L	5:1	326

MODEL	PRICE £	PRICE €	DESCRIPTION
C S56/059	£289.35	€332.75	Bags and ties (100 pack)
A S56/060	£3500	€4026	Lift-a Pak - Allows compacted bags to be easily lifted into storage skip
A S56/049	£1861	€2141	Additional trolley

MODEL	PRICE £	PRICE €	DESCRIPTION
C S56/055	£289.35	€332.75	Bags and ties (100 pack)
A S56/060	£3500	€4026	Lift-a Pak - Allows compacted bags to be easily lifted into storage skip
A S56/054	£2042	€2349	Additional trolley

IP600 Waste Compactor

- Small to large applications
- Cuts waste volumes by up to 80% and lowers waste handling and collection costs
- Compresses all dry waste - cardboard, tins, plastic and paper
- Powerful electro-hydraulic technology enables waste to be compacted in seconds
- Compact, easy-to-move unit can be conveniently located where waste is produced
- Manufactured from stainless steel making it tough, reliable and easy to clean
- UK 3 pin plug allows users to simply plug in and switch on



IP700 Waste Compactor

- Small to large applications
- Cuts waste volumes by up to 80% and lowers waste handling and collection costs
- Compacts waste directly into a wheelie bin
- Compresses all dry waste - cardboard, tins, plastic and paper
- Powerful electro-hydraulic technology enables waste to be compacted in seconds
- Compact, easy-to-move unit can be conveniently located where waste is produced
- Manufactured from stainless steel making it tough, reliable and easy to clean
- UK 3 pin plug allows users to simply plug in and switch on



Lincat

IP600 Waste Compactor											
MODEL	PRICE £	PRICE €	DESCRIPTION	H	W	D	POWER	STORAGE CAPACITY	EQUIVALENT UNCRUSHED	COMPACTION RATIO	WT
F56/600	£19,824	€22,798	IP600	1930	840	858	750W	210L	1050L	5:1	457

IP700 Waste Compactor											
MODEL	PRICE £	PRICE €	DESCRIPTION	H	W	D	POWER	STORAGE CAPACITY	EQUIVALENT UNCRUSHED	COMPACTION RATIO	WT
F56/700	£19,552	€22,484	IP700	1930	840	858	750W	240L	1200L	5:1	345

MODEL	PRICE £	PRICE €	DESCRIPTION
S S56/052	£289.35	€332.75	Bags and ties (100 pack)
A S56/060	£3500	€4026	LiftMate - Allows compacted bags to be easily lifted into storage skip
A S56/051	£2075	€2386	Additional trolley



LiftMate S56/060

60Hz models available, please see lincat.co.uk for details

IMClean

Cleaning & Rinsing

- Mobile Hand Wash Stations • Mobile Hand Sanitising Stations
- Power Brush • Compact Hose Reels



Meet stringent hygiene standards and save valuable staff time with effective cleaning and rinsing solutions.

From pots, cookware and utensils to kitchen wash-up areas, cleaning is always high on the agenda in catering operations. Our range of equipment includes pre-rinse sprays and pan scrubbers, mobile hand wash units and compact hose reels, enabling staff to work quickly and productively whilst improving hygiene standards.

A variety of Mobile Hand Wash Stations, with both heated and ambient models available, provide a simple, hygienic solution to help increase hygiene standards wherever required.

Remove food scraps, sauces and juices quickly and simply from crockery using a Pre-Rinse Spray, or more stubborn deposits from pans and cookware using a Pot Boy pan scrubber, significantly improving the effectiveness of subsequent dishwasher cleaning.

Compact, space-saving Reel-Kleen hose reels - with a retractable hose to reduce the risk of tripping - can be mounted on the wall, ceiling or floor, and are perfect for cleaning kitchen wash-up areas.

Benefits at a glance

- Helps meet healthy and safety, and hygiene standards
- Effective removal of food debris
- Saves time and increases efficiency
- Safe and easy to use

Ideally suited for...



Restaurants

Spend less time cleaning up and more time producing fine food and drink and delivering fantastic service. Pre-rinse Sprays improve dishwasher performance, guaranteeing clean, hygienic crockery and glassware.



Nurseries and schools

The IMClean Junior Mobile Reduced Height Hand Wash Station is more than just a sink. With its splashback, soap dispenser and paper towel holder it is a fully mobile, all-in-one compact solution which can be located anywhere - even the middle of the playground.



Cost Sector

Whether you're a school, hospital or university kitchen, speed up the cleaning of pans and cookware with Pot Boy. It is ideal for removing tough debris, saving on staff wash-up time.



Contents



Mobile Hand Wash Stations
Provide extra hand wash facilities without the need for plumbed services

Ideally suited for:
Organisations looking to extend their existing hand wash facilities.

Why choose a Mobile Hand Wash Station?

- Provide extra hand washing facilities
- No location restrictions, just fill with water and you are ready to go
- Tap dispense via foot action, ensures hygienic operation, with no need for hand contact
- Reduced height version available for nurseries and schools

Find out more on page **i96**



Pot Boy Power Brush
Remove burnt deposits from pans and cookware

Ideally suited for:
Restaurants and canteens, looking to meet stringent hygiene standards and save valuable staff time, with an effective cleaning solution.

Why choose a Pot Boy power brush?

- Effective removal of debris
- Saves time and increases efficiency
- Safe and easy to use

Find out more on page **i98**



Soak Tank
Remove stubborn carbon, fat and grease deposits from cookware

Ideally suited for:
Any establishment looking to meet stringent hygiene standards and save valuable staff time, with an effective cleaning solution.

Why choose a Soak Tank?

- Effective removal of debris
- Improve the effectiveness and efficiency of subsequent dishwasher cleaning
- Safely holds and transports a high volume of liquids and trays
- Compact footprint for busy kitchens
- Saves time and increases efficiency

Find out more on page **i98**



Reel Kleen Hose Reels
Space-saving hose reels

Ideally suited for:
Any establishment looking to meet stringent hygiene standards and save valuable staff time, with an effective cleaning solution.

Why choose a Reel Kleen hose reel?

- Space saving
- Mount to the ceiling, floor or wall
- Allows kitchen wash-up areas to be quickly and hygienically hosed down

Find out more on page **i98**

The IMClean

Mobile Hand Cleansing Station Product Line Up

We offer a range of Mobile Hand Cleansing Stations to suit any application



HEATED
NO PLUMBED SERVICES REQUIRED



HEATED
NO PLUMBED SERVICES REQUIRED

IMC Mobile Hand Wash Station F63/501

IMC Mobile Hand Wash Station F63/502

	Heated up to 42°C	Heated up to 42°C
WATER TEMPERATURE	Heated up to 42°C	Heated up to 42°C
OPERATION	Infra Red	Foot Pump
OVERALL POWER	3kW	3kW No power supply, use to dispense ambient temperature water.
WATER TANK CAPACITY	10 Litres	20 Litres Dispenses up to 100ml per foot press, delivering 200 dispenses from one tank.
DIMENSIONS H x W x D	1250mm x 450mm x 543mm	1220mm x 520mm x 543mm
REFILL / EMPTYING	Rear Access. Fixed tank fill using funnel. Easy to remove waste container.	Top fill. Front access easy to remove waste container.
NEW WEIGHT	41 kg	44 kg
LIST PRICE	£1737 / €1999	£1489 / €1713



IMC Mobile Hand Wash Station F63/503



IMC Mobile Hand Wash Station F63/700

WATER TEMPERATURE	Ambient	Ambient
OPERATION	Foot Pump	Foot Pump
OVERALL POWER	No power required!	No power required!
WATER TANK CAPACITY	20 Litres Dispenses up to 100ml per foot press, delivering 200 dispenses from one tank.	20 Litres Dispenses up to 100ml per foot press, delivering 200 dispenses from one tank.
DIMENSIONS H x W x D	1220mm x 520mm x 543mm	1003mm x 520mm x 592mm (700mm to counter top)
REFILL / EMPTYING	Front Access. Easy to remove fresh water and waste containers.	Front Access. Easy to remove fresh water and waste containers.
NEW WEIGHT	36 kg	33 kg
LIST PRICE	£977 / €1123	£977 / €1123

Pot Boy Power Brush

- Effectively removes burnt deposits from pans and cookware
- Compact design allows the Pot Boy to be mounted over sink units
- Can be moved by a trolley (optional) to fixed equipment, for cleaning in-situ
- Efficient, foot-operated pneumatic switch enables quick and easy operation
- Unique hydraulic system means brush is driven by a fluid circuit, for safety
- Tough, long-lasting nylon brush head
- Available with wall-mounting plate, to save space



S64/090 Trolley



U07/012 Nylon Brush Head



S64/103 Magikut Pads

Pot Boy Power Brush												
MODEL	PRICE £	PRICE €	DESCRIPTION	H	W	D	POWER	MOTOR (BHP)	HEAD SPEED	REACH OF HOSE	HOSE LENGTH	WT
F64/100	£8135	€9356	Pot Boy	265	625	245	370W	0.5	360rpm	2m	2m	25

MODEL	PRICE £	PRICE €	DESCRIPTION
S S64/090	£782	€900	Trolley
C S64/103	£394	€453.10	Magikut pads (5)
C U07/012	£218.40	€251.20	Nylon brush head

Soak Tank

- Remove stubborn carbon, fat and grease deposits from cookware and other kitchen utensils
- Improve the effectiveness and efficiency of subsequent dishwasher cleaning
- Safely holds and transports a high volume of liquid and trays
- Compact footprint for busy kitchens
- Accommodates four trays/baskets up to 675mm x 740mm x 95mm
- Lid with two oil and grease resistant handles for safe usage
- Wide drain valve for easy evacuation of the waste water
- Safety latch on drain valve to protect from accidental evacuation of the waste water
- Tank trolley with braked castors - easy to manoeuvre and lock in position
- Enclosed tray - for storing PPE required for handling undiluted chemicals (goggles and gauntlets)
- Fully welded grade 304 stainless steel construction - provides superior resistance to corrosion from water



Soak Tank									
MODEL	PRICE £	PRICE €	DESCRIPTION	H	W	D	CAPACITY	WT	
F64/200	£1931	€2221	Soak Tank	858	360	868	140L	40	

Electricity Supply Requirements

Electrical products not listed on this page are supplied for operation on a 230/240v, 13 amp supply.

Brand	Product Code	Power Supply/ Connection Type	Electrical Supply Rating [watts]	Single Phase		Three Phase			
				Amps	Voltage	Amps - Phase 1	Amps - Phase 2	Amps - Phase 3	Voltage
IMC	F52/301	1-phase	550	5.2	230				
IMC	F52/321	3-phase [4 wire]	550		N/A	1.7	1.7	1.7	400
IMC	F52/500	1-phase	550	5.2	230				
IMC	F52/510	1-phase	550	5.2	230				
IMC	F52/520	3-phase [4 wire]	550		N/A	1.7	1.7	1.7	400
IMC	F52/530	3-phase [4 wire]	550		N/A	1.7	1.7	1.7	400
IMC	F52/602	1-phase	550	5.2	230				
IMC	F52/612	1-phase	550	5.2	230				
IMC	F52/622	3-phase [4 wire]	550		N/A	1.7	1.7	1.7	400
IMC	F52/632	3-phase [4 wire]	550		N/A	1.7	1.7	1.7	400
IMC	F54/100	1-phase	1,100	7.4	230				
IMC	F54/120	3-phase [4 wire]	1,100		N/A	2.8	2.8	2.8	400
IMC	F54/220	3-phase [4 wire]	2,200		N/A	4.8	4.8	4.8	400
IMC	F54/320	3-phase [4 wire]	4,000		N/A	9.4	9.4	9.4	400
IMC	F54/322	3-phase [4 wire]	4,000		N/A	8.7	8.7	8.7	400
IMC	F54/500	1-phase	1,100	7.4	230				
IMC	F54/520	3-phase [4 wire]	1,100		N/A	2.8	2.8	2.8	400
IMC	F54/521	3-phase [5 wire]	1,100		N/A	2.8	2.8	2.8	400
IMC	F54/620	3-phase [5 wire]	2,200		N/A	5.1	5.1	5.1	400
IMC	F54/621	3-phase [4 wire]	2,200		N/A	5.1	5.1	5.1	400
IMC	F54/720	3-phase [5 wire]	4,000		N/A	8.7	8.7	8.7	400
IMC	F54/721	3-phase [4 wire]	4,000		N/A	8.7	8.7	8.7	400
IMC	F54/724	3-phase [4 wire]	2,200		N/A	4.8	4.8	4.8	400
IMC	F54/725	3-phase [4 wire]	2,200		N/A	5.1	5.1	5.1	400
IMC	F54/726	3-phase [5 wire]	2,200		N/A	5.1	5.1	5.1	400
IMC	F54/727	3-phase [4 wire]	4,000		N/A	9.4	9.4	9.4	400
IMC	F54/728	3-phase [4 wire]	4,000		N/A	8.7	8.7	8.7	400
IMC	F54/729	3-phase [5 wire]	4,000		N/A	8.7	8.7	8.7	400
IMC	F54/730	1-phase	1,100	7.4	230				
IMC	F54/731	3-phase [4 wire]	1,100		N/A	2.8	2.8	2.8	400
IMC	F54/732	1-phase	1,100		N/A	2.8	2.8	2.8	400
IMC	F54/733	3-phase [4 wire]	1,100		N/A	7.4	7.4	7.4	400
IMC	F54/734	3-phase [5 wire]	1,100		N/A	2.8	2.8	2.8	400
IMC	F56/401	EU 2 Pin Plug	750	5	230				
IMC	F56/501	EU 2 Pin Plug	750	5	230				
IMC	F56/601	EU 2 Pin Plug	750	5	230				
IMC	F56/701	EU 2 Pin Plug	750	5	230				
IMC	F58/901	3-phase	370		N/A	1.1	1.1	1.1	400
IMC	F58/903	3-phase	370		N/A	1.1	1.1	1.1	400
IMC	F58/911	3-phase	750		N/A	2.1	2.1	2.1	400
IMC	F58/913	3-phase	750		N/A	2.1	2.1	2.1	400
IMC	F59/440	3-phase	1,100		N/A	1.1	1.1	1.1	400
IMC	F59/500	1-phase	330	1.6	230				
IMC	F59/500/L	1-phase	330	1.6	230				
IMC	F59/510	1-phase	481	2.1	230				
IMC	F59/510/L	1-phase	481	2.1	230				
IMC	F59/511	3-phase	660		N/A	0.4	0.4	0.4	400
IMC	F59/511/L	3-phase	660		N/A	0.4	0.4	0.4	400
IMC	F59/520	1-phase	481	2.1	230				
IMC	F59/520/L	1-phase	481	2.1	230				
IMC	F59/521	3-phase	660		N/A	0.4	0.4	0.4	400
IMC	F59/521/L	3-phase	660		N/A	0.4	0.4	0.4	400
IMC	F59/710	1-phase	481	2.1	230				
IMC	F59/720	3-phase	660		N/A	0.4	0.4	0.4	400
IMC	F59/730	1-phase	481	2.1	230				
IMC	F59/740	3-phase	660		N/A	0.4	0.4	0.4	400
IMC	F60/100	1-phase	1,100	7.4	230				
IMC	F60/120	3-phase [5 wire]	1,100		N/A	2.8	2.8	2.8	400
IMC	F60/121	3-phase [4 wire]	1,100		N/A	2.8	2.8	2.8	400
IMC	F60/200	1-phase	1,100	7.4	230				
IMC	F60/220	3-phase [5 wire]	1,100		N/A	2.8	2.8	2.8	400
IMC	F60/221	3-phase [4 wire]	1,100		N/A	2.8	2.8	2.8	400
IMC	F60/305	1-phase	1,100	7.4	230				
IMC	F60/310	3-phase [4 wire]	1,100		N/A	2.8	2.8	2.8	400
IMC	F60/404	3-phase [4 wire]	1,100		N/A	2.8	2.8	2.8	400
IMC	F60/444	3-phase [4 wire]	1,100		N/A	2.8	2.8	2.8	400
IMC	F60/500	1-phase	1,100	7.4	230				
IMC	F60/505	3-phase [5 wire]	1,100		N/A	2.8	2.8	2.8	400
IMC	F60/515	3-phase [5 wire]	1,100		N/A	2.8	2.8	2.8	400
IMC	F60/555	1-phase	1,100	7.4	230				
IMC	F68/120	3-phase [5 wire]	2,200		N/A	5.3	5.3	5.3	400
IMC	F68/121	3-phase [4 wire]	2,200		N/A	5.3	5.3	5.3	400
IMC	F68/220	3-phase [5 wire]	2,200		N/A	5.3	5.3	5.3	400
IMC	F68/221	3-phase [4 wire]	2,200		N/A	5.3	5.3	5.3	400
IMC	F68/324	3-phase [4 wire]	2,200		N/A	5.3	5.3	5.3	400
IMC	F68/325	3-phase [5 wire]	2,200		N/A	5.3	5.3	5.3	400
IMC	F68/326	3-phase [4 wire]	2,200		N/A	5.3	5.3	5.3	400
IMC	F68/327	3-phase [5 wire]	2,200		N/A	5.3	5.3	5.3	400
IMC	F78/020	3-phase [4 wire]	1,950		N/A	5.5	5.5	5.5	400
IMC	F78/030	3-phase [4 wire]	1,950		N/A	5.5	5.5	5.5	400
IMC	F79/010	3-phase	4,100		N/A	8.62	8.62	8.62	380-415
IMC	F79/100	3-phase	4,100		N/A	8.62	8.62	8.62	380-415
IMC	F79/701	1-phase	2,950	13	230				
IMC	F79/703	3-phase	2,950		N/A	4.3	4.3	4.3	400

All weights stated are packed weights.

Warning UK: In accordance with The Gas Safety (Installation and Use Amendment Regulations 1998) gas appliances must be installed by commercial catering equipment engineers certified by the Gas Safety Register. Failure to comply with this will render any non registered installer liable to prosecution and will invalidate the guarantee.

For Sale terms and conditions please visit lincat.co.uk/sale-terms-conditions





Britannia

2026 PRICE LIST



SPECIALISING IN

- VENTILATION
- RECIRCULATION



Contents



Create a clean and fresh working environment
Ventilation

Ideally suited for:

Fast food outlets, smaller pubs and restaurants and cafes, ensure that your staff are focused only on delivering the very best quality food by keeping the air clean and clear.

Why choose SmartVent?

- Easy to install
- Efficiently remove kitchen smoke and odours
- Provides a safer and more comfortable place for staff to work in
- A real alternative to expensive bespoke kitchen ventilation
- Great for tight installation deadlines
- Gas and electric compatible
- Modular in design and robustly constructed

Find out more on page **B3**



Providing a safer, more comfortable and productive working environment
Recirculation

Ideally suited for:

Restricted buildings, concession areas, temporary catering, pubs, snack bars and coffee shops where venting to the atmosphere is impossible or costly.

Why choose Refresh?

- Quick and easy to install
- Filtration process removes grease, fine particles, smoke and odours
- Provides a safer, more comfortable and productive working environment
- For use with electrical appliances
- Constructed from polished stainless steel for long term durability and easier cleaning

Find out more on page **B5**

2 YEAR UK parts and labour warranty | Export parts warranty
on all IMC products

All prices are exclusive of VAT.

UK
Goods are normally delivered free of charge to either the dealers' address or direct within 3 working days. If overnight and/or premium services are required charges will apply.

Export
Goods are priced ex works, export crates POA.

- ☎ UK Tel: 01522 875500
- ☎ Export Tel: +44 1522 503250
- ✉ UK e-mail: sales@lincat.co.uk
- ✉ Export e-mail: export@lincat.co.uk



Britannia



SmartVent creates a clean and fresh working environment

The SmartVent Canopy Extraction System is designed to efficiently remove kitchen smoke and odours, making your kitchen a safer and more comfortable place for staff to work in.

A real alternative to expensive bespoke kitchen ventilation, the system is modular in design and robustly constructed. Facing challenging

installation deadlines? The SmartVent Canopy Extraction System can help with that.

The cost-effective system is flexible, with four different length options, it's easy to install, and it's compatible with both gas and electric cooking equipment.

Ideally suited for...

The SmartVent Canopy Extraction System is perfect for the cost conscious buyer working to tight deadlines. It suits a variety of venues, including the following:



Fast food outlets

Are your staff working flat out to deliver quality fast food around the clock? Keep them cool and safe while they work.



Smaller pubs and restaurants

Ensure that your staff are focused only on delivering the very best quality food by keeping the air clean and clear.



Cafes

Perfect for removing smoke and odours to make for a more comfortable experience for your staff as well as your customers.

Efficiently remove kitchen smoke and odours, making your kitchen safer and more comfortable for staff to work in.

Benefits at a glance

- Flexible
- Efficient
- Easy to install
- Cost-effective
- Great for tight installation deadlines
- Gas and electric compatible



SmartVent Canopy Extraction Ventilation System

- Canopy extraction system suitable for use with gas and electric cooking equipment up to 900 series
- Choice of fan position (please see box at bottom of page)
- Variable fan speed enables selection of the required level of ventilation to suit kitchen output throughout the day
- Reduces energy consumption by using lower fan speeds during quieter periods
- Bright energy-efficient LED lighting provided as standard
- Supplied with a wall mounted variable fan speed controller
- Simple to install



1200mm long SmartVent							
MODEL	PRICE £	PRICE €	L	W	D	POWER	WT
SV1212	£3600	€4140	1200	1200	748	0.12kW	85



1600mm long SmartVent							
MODEL	PRICE £	PRICE €	L	W	D	POWER	WT
SV1216	£3909	€4496	1200	1600	740	0.12kW	105



2000mm long SmartVent							
MODEL	PRICE £	PRICE €	L	W	D	POWER	WT
SV1220	£4582	€5271	1200	2000	740	0.12kW	126



2400mm long SmartVent							
MODEL	PRICE £	PRICE €	L	W	D	POWER	WT
SV1224	£5033	€5787	1200	2400	740	0.12kW	147

Please note that ductwork and gas interlocks are not included. Please contact our sales desk for advise on suppliers.

When placing an order please specify your preferred fan position by adding one of the following codes to the end of the SmartVent model number.

LH - Left fan horizontally mounted	CH - Central fan horizontally mounted	RH - Right fan horizontally mounted
LV - Left fan vertically mounted	CV - Central fan vertically mounted	RV - Right fan vertically mounted

Example: SV1216RH = 1600mm long canopy with fan positioned to the right and exiting horizontally.
Please refer to the SmartVent brochure for further details.

Britannia

kitchen ventilation

Refresh
Recirculation Unit



For kitchens that require ventless cooking, the Refresh range of self-contained kitchen ventilation and air recirculation systems are the ideal solution.

Free-standing Refresh units are available in a range of sizes and can be installed quickly and easily, with minimal disruption to service. They are equipped with an extract and supply canopy, along with a services tower that houses a powerful, efficient fan unit. Air is drawn out through the canopy, before passing through five filtration stages to remove grease, fine particles, smoke and odours.

The grease and smoke is filtered from the airstream, before passing through a carbon filter set to reduce odours. Filtered air is then reintroduced into the kitchen.

Constructed using durable stainless steel, Refresh units come with a pre-programmed fan control system, filter life monitoring and cook-line equipment interlock interface. The unit is manufactured to the ISO 9001-2015 quality standard.

Ideally suited for...

Struggling with venting to the atmosphere? Solve the problem with Refresh ventilation and recirculation units. They are ideal for a wide range of locations, including:



Restricted buildings

From high-rise buildings to basements, and properties with listed status and planning restrictions, Refresh is the ideal solution. Where venting to the atmosphere is impossible, difficult or costly, it provides a safer, more comfortable working environment.



Concession areas

Concession areas in airports and transport concourses can be difficult locations to vent to the atmosphere. Refresh units require no venting and filter air, providing a better kitchen space for staff



Pubs, snack bars and coffee shops

Ventless cooking is ideal for smaller pubs, snack bars and coffee shops, where ventilation to the atmosphere is difficult or costly. Refresh units are quick and easy to install, and provide a safer, more comfortable working space.

Make your kitchen safer, cleaner and more comfortable with a Refresh ventilation unit.

Benefits at a glance

- No venting required
- For use with electrical appliances
- Accommodate multiple pieces of equipment
- Quick and easy to install
- Multi-stage filtration
- Filter monitor and fan control systems
- Manufactured to ISO 9001-2015
- Durable construction
- Cook-line can be interlocked to the unit

Refresh Recirculation Units

- Highly efficient four stage sequential filtration process removes grease, fine particulate, smoke and odour
- Ideal for use where venting to the atmosphere is impractical
- Suitable for use with electric cooking equipment only
- Free standing in design, their flexibility can increase output in existing kitchens or allow the set up of a cooking station in previously unsuitable areas of a building



Refresh Mini Recirculation Unit										
MODEL	PRICE £	PRICE €	DESCRIPTION	COOKLINE LENGTH	H	W	D	POWER	WT	
* Y10030	£9284	€10,678	Refresh Mini	500	2222	555	734	190W	131	

MODEL	PRICE £	PRICE €	DESCRIPTION
\$ SE100/109	£102.50	€117.95	Baffle filter
\$ SE100/103	£107	€123.05	Carbon filter
\$ SE100/100	£28.25	€32.45	G4 filter set
\$ SE100/106	£455.85	€524.30	HEPA filter

Refresh Midi Recirculation Unit										
MODEL	PRICE £	PRICE €	DESCRIPTION	COOKLINE LENGTH	H	W	D	POWER	WT	
* Y10020	£11,945	€13,737	Refresh Midi	1000	2222	1050	734	190W	183.5	

MODEL	PRICE £	PRICE €	DESCRIPTION
\$ SE100/110	£200.40	€230.50	Baffle filter
\$ SE100/104	£210.55	€242.15	Carbon filter
\$ SE100/101	£51.90	€59.65	G4 filter set
\$ SE100/107	£908.30	€1044.55	HEPA filter

Refresh Maxi Recirculation Unit										
MODEL	PRICE £	PRICE €	DESCRIPTION	COOKLINE LENGTH	H	W	D	POWER	WT	
* Y10010	£16,927	€19,466	Refresh Maxi	1500	2222	1551	734	380W	246	

MODEL	PRICE £	PRICE €	DESCRIPTION
\$ SE100/111	£296.10	€340.55	Baffle filter
\$ SE100/105	£313	€359.95	Carbon filter
\$ SE100/102	£134.35	€161.30	G4 filter set
\$ SE100/108	£1358.45	€1562.25	HEPA filter

Please note: Range ovens and fryers are for illustrative purposes and not included

* Please refer to page B7 for electricity supply requirements

Electricity Supply Requirements

Electrical products not listed on this page are supplied for operation on a 230/240v, 13 amp supply.

Brand	Product Code	Power Supply/ Connection Type	Electrical Supply Rating [watts]	Single Phase		Three Phase			
				Amps	Voltage	Amps - Phase 1	Amps - Phase 2	Amps - Phase 3	Voltage
Britannia	Y10010	16A Commando Plug	3,500	1.65	220	-	-	-	-
Britannia	Y10020	16A Commando Plug	3,500	0.68	220	-	-	-	-
Britannia	Y10030	16A Commando Plug	3,500	0.68	220	-	-	-	-

All weights stated are packed weights.

Warning UK: In accordance with The Gas Safety (Installation and Use Amendment Regulations 1998) gas appliances must be installed by commercial catering equipment engineers certified by the Gas Safe Register. Failure to comply with this will render any non registered installer liable to prosecution and will invalidate the guarantee.

For Sale terms and conditions please visit lincat.co.uk/sale-terms-conditions

Sale Terms & Conditions

Standard Terms & Conditions of Sale

1. DEFINITIONS and GENERAL

1. The Company – Lincat Limited, Whisby Road, Lincoln LN6 3QZ
2. The Buyer – the person, firm or company contracting with the Company.
3. The Contract – any contract between the Company and the Buyer for the sale and purchase of goods upon these terms and conditions.
4. All orders are accepted subject to these Conditions of Sale which shall apply to the exclusion of any terms or conditions put forward by or on behalf of the Buyer.
5. No variation, waiver or addition to these conditions, whether written or oral, shall have effect unless agreed in writing by the Company.

2. DESCRIPTION

1. Although every effort has been made to ensure that the illustration, price, description, measurement and specification of goods in our catalogues, brochures and on the website are correct such information is published for the sole purpose of giving an approximate idea of the goods represented by or described in them. They will not form part of the Contract and this is not a sale by sample. Where any such details are important the Buyer should themselves verify the information before placing an order.
2. The Company reserves the right to modify or vary the design, specification or finish of any of our products without notice.

3. ORDERS

1. The Buyer shall be responsible to the Company for ensuring the accuracy of any order.
2. Cancellations will only be accepted at the Company's discretion. Orders for products with factory fitted options, for example customised products from FriFri, Panther, IMC, are strictly non-cancellable. In the event of a cancellation the Company reserves the right to charge the Buyer against all loss (including loss of profit), costs (including the cost of all material and labour used) damages, charges and expenses incurred by the Company as a result of cancellations.

4. PRICE OF GOODS

1. The price of the goods shall be the price listed in the Company's published price list current at the date of despatch of the order less agreed discount.
2. The price of the goods is exclusive of Value Added Tax, which will be charged at the applicable rate at the date of invoice.
3. The price of the goods includes the cost of carriage by the Company's standard three day service to mainland England, Scotland (excluding Highlands) and Wales. Deliveries to other destinations will be charged separately where the Company undertakes delivery of the goods.
4. In the event of any increase in the cost to the Company of supplying the goods caused by any reason whatsoever the Company may on giving notice to the Buyer at any time before delivery adjust the price.

5. TERMS OF PAYMENT

1. The Buyer shall pay the price of the Goods without any deduction within 30 days of the end of the month in which the goods are invoiced. Time for payment will be of the essence. No payment will be deemed to have been received until the Company has received clear funds. All sums payable under the Contract will become due immediately upon termination of the Contract. The Company reserves the right to claim settlement of any outstanding amounts due before this date if there is any change in the financial circumstances of the Buyer.
2. In the event that any payment due to the Company is withheld or delayed the Company reserves the right:
 1. to suspend any further deliveries to the Buyer
 2. charge interest at 2.5% pa above the base lending rate from time to time of the Royal Bank of Scotland Plc on the amount outstanding from the date when payment becomes due until the date of payment.
 3. to recover from the Buyer on a full indemnity basis together with interest thereon all costs incurred by it in obtaining payment including solicitor's fees and costs associated with so doing.

6. DELIVERY

1. The Company will use reasonable endeavours to deliver the goods within the time agreed when the Buyer places an order and, if no time is agreed, then within a reasonable time, but the time of delivery will not be of the essence. If, despite those endeavours, the Company is unable for any reason to fulfil any delivery or performance on the specified date, the Company will be deemed not to be in breach of the Contract, nor (for the avoidance of doubt) will the Company have any liability to the Buyer for direct, indirect or consequential loss (all three of which terms includes, without limitation, pure economic loss, loss of profits, loss of business, depletion of goodwill and like loss) howsoever caused (including as a result of negligence) by any delay or failure in delivery except as set out in this condition.
2. Any costs incurred due to inadequate site access shall be charged to the Buyer.
3. If the Buyer fails to take delivery of the goods the Company shall be entitled to invoice and be paid for the goods as though they had been duly delivered. The Company may arrange storage of the goods until actual delivery and charge the Buyer for the reasonable costs of storage.
4. It is the Buyer's responsibility to inspect the goods at the time of delivery. The Company accepts no responsibility for alleged non-delivery, shortfall of goods, damage on delivery or other discrepancy unless notification in writing is received within 24 hours from the date of delivery. In the absence of such notification the Buyer shall be deemed to have accepted the goods.

7. RETURNS

1. Goods despatched to the Buyer and subsequently accepted for cancellation by the Company will be subject to an abortive delivery charge, as well as any cancellation charge deemed necessary by the Company.

2. The Company at its absolute discretion may agree to the return of goods by the Buyer within 28 days of delivery, provided that the goods are returned at the Buyer's expense, in the same condition and in the original packaging.
3. Any goods agreed by the Company as acceptable for return for any reason (excluding faulty goods) will be subject to a restocking charge of 25% of the net invoiced price, together with the reimbursement of any expense incurred by the Company as a consequence of the return of said goods to the Company's stock.

8. RISK AND PROPERTY

1. Risk of damage to or loss of the goods shall pass to the Buyer at the time of delivery or, if the Buyer wrongfully fails to take delivery of the goods, the time when the Company has tendered delivery of the goods.
2. Notwithstanding delivery and the passing of risk in the goods the property in the goods shall not pass to the Buyer until the full price of the goods and goods which are subject to any other contract between the Buyer and the Company is received in full in cash or cleared funds.
3. Until such time as the property in the goods passes to the Buyer they shall be held by the Buyer in a fiduciary capacity and stored by the Buyer at its premises in such a manner that they are clearly identifiable as the goods of the Company and shall be kept separate from any other goods whether or not supplied by the Company. Until that time the Buyer shall be entitled to sell the goods in the ordinary course of its business but shall account to the Company for the proceeds of sale.
4. Until such time as the property in the goods passes to the Buyer the Company shall be entitled at any time to require the Buyer to deliver up the goods to the Company and if the Buyer fails to do so forthwith to enter upon any premises of the Buyer or any third party where the goods are stored and repossess the goods. The Buyer hereby grants an irrevocable licence to the Company for this purpose.

9. WARRANTY, EXCLUSION OF LIABILITY AND INDEMNITY

1. Warranty
 1. In respect of goods (excluding spare parts and consumable items such as door seals, filters, bulbs, glass and LTX toaster elements) which are proved to the reasonable satisfaction of the Company to be damaged or defective due to defects in material or workmanship, the Company will, free of charge, within a period of 24 months (12 months for IMC Mobile Hand Wash Stations, and the Lynx Prime range) from the date of resale of such goods by The Buyer, either (at the Company's option):
 - repair such goods; or
 - replace such goods; or
 - refund the purchase price of the goods.
 (This applies to Mainland UK only. Exported goods are covered for parts only.)
 2. The obligation in condition 9.1.1 above will not apply where:
 1. the goods have been improperly altered in any way whatsoever, or have been subject to misuse or unauthorised repair;
 2. the goods have been improperly installed or connected;
 3. any maintenance requirements relating to the goods have not been complied with.
 4. the goods are gas powered and have been installed into a mobile catering outlet such as, but not limited to, a catering trailer, in which case the Company's obligation is limited to the free-of-charge supply of spare parts.
 3. Any goods which have been replaced will belong to the Company. Any repaired or replacement goods will be liable to repair, replacement or refund under the terms specified in condition 9.1.1 for the unexpired portion of the 24 month period from the original date of resale of the repaired or replaced goods.
2. Exclusion of liability
 1. for breach of the Company's obligations arising under section 12 Sale of Goods Act 1979 or section 2 Sale and Supply of Goods and Services Act 1982
 2. for personal injury or death resulting from the Company's negligence
 3. under section 2 (3) Consumer Protection Act 1987
 4. for any matter which it would be illegal for the Company to exclude (or to attempt to exclude) its liability, or
 5. for fraud.
3. Except as provided in Conditions 6.1 and 9.1.1 to 9.2.2 the Company will be under no liability to the Buyer whatsoever (whether in contract, tort (including negligence), breach of statutory duty, restitution or otherwise) for any injury, death, damage or direct, indirect or consequential loss (all three of which terms include, without limitation, pure economic loss, loss of profits, loss of business, depletion of goodwill and like loss) howsoever caused arising out of or in connection with:
 1. any of the goods, or the manufacture or sale or supply, or failure or delay in supply, of the goods by the Company or on the part of the Company's employees, agents or sub-contractors
 2. any breach by the Company of any of the express or implied terms of the Contract
 3. any use made or resale by the Buyer of any of the goods, or of any product incorporating any of the goods; or
 4. any statement made or not made, or advice given or not given, by or on behalf of the Company
 5. or otherwise under the Contract
4. Except as set out in conditions 6.1 and 9.1.1 to 9.2.2 the Company hereby excludes to the fullest extent permissible in law, all conditions, warranties and stipulations, express (other than those set out in the Contract) or implied, statutory, customary or otherwise which, but for such exclusion, would or might subsist in favour of the Buyer.
5. Each of the Company's employees, agents and sub-contractors may rely upon and enforce the exclusions and restrictions of liability in conditions 6.1 and 9.2.1 to 9.2.3 in that person's own name and for that person's own benefit, as if the words "its employees, agents and sub contractors" followed the word Company wherever it appears in those conditions save each reference in condition 9.2.3.1

6. The Buyer acknowledges that the above provisions of this Condition 9 are reasonable and reflected in the price which would be higher without those provisions, and the Buyer will accept such risk and/or insure accordingly.
7. Subject to condition 9.2.2 the Company's aggregate liability under the Contract whatsoever (whether in contract, tort (including negligence), breach of statutory duty, restitution or otherwise) and howsoever arising to the Buyer will be limited to the price of the goods.

10. FORCE MAJEURE

1. The Company shall not be liable in respect of any breach of contract due to any cause beyond its reasonable control including Act of God, inclement weather, flood, lightning or fire, industrial action or lockouts, actions of government departments, war, riot or terrorism, or the action of any party for whom the Company is not directly responsible.

11. SEVERABILITY

1. If any condition or part of the Contract is found by any court, tribunal, administrative body or authority of competent jurisdiction to be illegal, invalid or unenforceable then that provision will, to the extent required, be severed from the Contract and will be ineffective without, as far as is possible, modifying any other provision or part of the Contract and this will not affect any other provisions of the Contract which will remain in full force and effect.

12. ENTIRE AGREEMENT

1. The Contract contains all the terms which the Company and the Buyer have agreed in relation to the goods and supersedes any prior written or oral agreements, representations or understandings between the parties relating to such goods. The Buyer acknowledges that it has not relied on any statement, promise or representation made or given by or on behalf of the Company which is not set out in the Contract.

13. LAW AND JURISDICTION

1. The Contract shall be governed and construed in all respects in accordance with the Laws of England and shall be subject only to the jurisdiction of the English Courts.

Clarified warranty conditions

1. General

Installation – Equipment should be installed by a qualified person and located as per the instructions. Supplied services (Gas, Electricity and Water) should meet the specification supplied with the equipment and conform to current regulations. Gas pressure must meet the specification in the installation manual.

Maintenance – Users are required to regularly clean equipment and ensure servicing is carried out when required. Gas equipment should be serviced at least annually.

Modifications – any modification to the equipment will invalidate the warranty.

User damage – any damage to the equipment that affects its usage will invalidate the warranty. This includes use of incorrect cleaning agents.

2. Access

Service engineer visits are made between 8:30 a.m. and 5:00 p.m. on weekdays.

It is the customer's responsibility to ensure that the service engineer can access the equipment to effect repairs. Waiting time and abortive calls will be charged to the customer.

3. General exclusions

Gas

Gas products are supplied for either LPG or Natural Gas use and must be connected to the correct gas. All installations must conform to current gas regulations. Gas supplies must attain the minimum pressure levels as indicated in the instructions at all times. If a regulator is supplied with the unit then it must have been fitted correctly and set to the required pressure.

Electric (excluding equipment supplied with BS 1363 plugs)

All products must be connected to supplies with the correct voltage and phasing by a qualified electrician and comply with current regulations.

Water – all except filter flow

Any issue identified as a result of the water supply, e.g. water pressure or water hardness is not covered by the warranty. De-scaling is chargeable to the customer. Filter systems must be capable of maintaining correct levels of treated water, and users must ensure filters are changed regularly.

Specific general exclusions

- Damage to control knobs and buttons due to misuse.
- Discolouration of components due to heat.
- Resolving drainage problems where drainage does not meet requirements.
- Lubrication of moving parts.
- Corrosion caused by the use of chemical cleaners.
- Replacement of components due to internal contamination as a result of spillage or accumulation of grease/food debris due to a lack of cleaning.
- Cabinet, drawer and door seals are considered consumable items and will not be replaced under warranty.
- Light bulbs and lens covers are considered consumable items and will not be replaced under warranty.
- Enamel coated components if impacted sufficiently will crack or chip, such damage is not covered by the terms of this warranty.
- Rectification where non-Lincat specified parts have been used.
- Where user error is established, or no fault is found.
- Hinges when the damage has been caused by the user, and not a product defect.

- Replacement of hot plates when cracked due to external spillage, accumulation of grease, or food debris due to lack of cleaning.
- Door components are not covered by warranty when deemed misuse.

4. Additional exclusions by type

Gas general

- Poor combustion caused by lack of cleaning.
- Failure of components directly linked to poor cleaning and/or maintenance.
- Cleaning of burners jets.
- Cleaning/adjustment of pilots and thermocouples.
- Correction of gas pressure to the appliance.
- Lubrication of gas valves.
- Renewing of gas supply fittings external to the appliance.

Electrical general

- Resetting of safety devices including fuses where no other fault exists.
- Renewing of supply cable ends.
- Terminal blocks when the damage occurs at the supply end and is not a product defect.

Filter Flow

- Failure to replace the filter with a Lincat supplied item.
- Descaling of the unit.
- Damage to the elements resulting from mechanical descaling e.g. using a scraper.

Fryers

- Cleaning and un-blocking of fryer filter systems due to customer misuse.
- Replacement of components damaged by cooking oils due to a lack of cleaning and care when replacing oil.
- Damage to thermostats.

Induction

- Chipped or damaged glass not reported at time of delivery.
- Damage due to blocked or missing air filters.

Chargrills and salamanders with Ceramic burners

- Impact damage caused by the user.

Chargrill Radiant covers

- Radiant covers are considered consumable items and may corrode if not regularly cleaned due to prolonged contact with salt and fats and will not be replaced under warranty.
- Damage to heaters due to failure to replace radiant covers is not covered by the warranty.

Heated and chilled food displays

- Chipped or damaged glass not reported at time of delivery.
- Damage to components resulting from restricted airflow to inlets and outlet.
- Damage to components resulting from accumulation of airborne particles.
- Condensation on cold surfaces if units are installed in environments beyond specification.

Combi and Bake ovens

- Damage resulting from lack of water flow to the unit.
- Where damage has arisen due to lack of descaling, or incorrect/no cleaning products being used where manufacturers guidelines advise they should be.
- Glass in doors.

5. Replacement units additional conditions

Lincat may choose to replace a unit that requires repair.

Lincat reserve the right to send an engineer to attempt a repair before a replacement is offered.

If no fault is found Lincat reserves the right to charge for the replacement. Acceptance of delivery of a new unit is acceptance of this condition by the customer.

Any goods which have been replaced will belong to the Company. Any repaired or replacement goods will be covered for the unexpired portion of the original warranty.

The Lincat Edge

Here at Lincat we have values which run through our company and that are incredibly important to all of us. These values are reflected in the decisions that we make and guide everything that we do.

01. We're focused on you

Our passion is delivering what our customers want and need in order for them create fabulous food and to succeed.

05. We're never satisfied

We always strive to do things better. We know we're not perfect, but we work with the mantra of learning and improving every day. We don't take your business for granted.

02. We're driven by delivering quality

At Lincat our focus is on delivering only the best quality products. It's a mantra that goes into all of the work that we do at our state of the art manufacturing facility in our home town of Lincoln.

06. We're innovative

10% of our employees - from chefs to engineers - are focused on creating innovative equipment to make your life easier.

03. We're foodies at heart

Food is a passion for us. That's why we strive to provide the very best equipment for you to achieve excellent results and deliver delicious dishes time after time.

06. We find solutions

Whether you bake, grill, boil or fry on a small scale for a cafe, or cook on a huge scale at a hospital, we're confident that we can find a solution for you.

04. We're reliable

We're extremely confident in the quality and durability of our products. They won't let you down and neither will we.

08. We're agile

We're flexible and can move quickly to help you. If you need something, we will find a way to help.

PRODUCT CODES: /N = natural gas /P = propane gas Btu/hr = kW x 3412



Gas



Electric



Accessories



Spare Parts



Factory Fit Options



Consumables

Lincat

GREEN RANGE

SHAPING THE FUTURE



Less oil
usage



Less energy
usage



Labour
saving



Less food
waste



Speedier
cooking



Increased
food yield



Less water
waste



Less detergent
waste



Transport
saving

Lincat

GREEN RANGE

In response to increasing customer interest in the sustainable solutions we offer, we have brought together products in our portfolio which use less oil, offer energy and/or labour savings, reduce food waste, faster cooking, increased food yield and/or transport savings.

2

YEAR

UK parts
and labour
warranty

Contents



Combi Ovens : **G3/4**



Induction Oven Ranges & Hobs : **G5/7**



Electric Fryers : **G8/9**



Gas Fryer : **G10**



Salamanders : **G11/13**



Clam Griddles : **G14**



Gas Chargrills : **G15**



Electric Chargrills : **G16**



High Speed Ovens : **G17/18**



Eco Toaster : **G19**



Hot Holding Bins : **G20**



Hot Air Merchandisers : **G21**



Water Boilers : **G22**



Food Waste Management : **G23**



Dry Waste Compactors : **G24**

Combi & Bake Ovens

Delivering across the range



Reduced energy usage



Labour saving



Speedier cooking



Reduced food waste

LQC106

LQB9



Lincat Invoq

Helps you move towards a **more sustainable kitchen!**

☰ CONVECTION

19% LESS ENERGY
USED PER RUNNING HOUR

Technology behind the scenes:

- Triple layer glass door
- Improved airflow contributing to the Maillard reaction
- Improved air intake - three times faster dehumidification
- Energy-efficient insulation

☁ STEAM

70% LESS ENERGY
USED PER RUNNING HOUR

Technology behind the scenes:

- Improved steam saturation based on lambda sensor
- Improved boiler performance (%)
- HybridSteam implementation
- Closed drain system

17% MORE CAPACITY

An extra tray in Combi and Hybrid 6 grid ovens

⊕ CLEANING

70.7% LESS COSTS
27% LESS WATER
63% LESS TIME

Technology behind the scenes:

- Recirculating cleaning system
- Less and greener chemicals
- Cleaning programs to match your needs

💰 YOUR SAVINGS

COST SAVINGS OF
£1,401/€1,612
PER YEAR

User scenario based on following operation:

- Eight hours a day (six hours convection, two hours steaming, one medium cleaning)
- Five days a week
- 48 weeks a year

Based on a kWh price of € 0.46 and a water price of €1.45 per m3. Comparison: Invoq Hybrid 10-1/1 GN up against predecessor model.

20% MORE CAPACITY

An extra tray in the Bake 6 oven

Combi Slim Ovens

Delivering across the range



Reduced energy usage



Labour saving



Speedier cooking



Reduced food waste



Lincat CombiSlim

COMPACT
FOOTPRINT
→ 513MM ←
WIDE

maximise valuable counter space

REDUCE
WASTE. 
SmartChef®
PRESET RECIPES

consistent results regardless of the operator

CombiWash®
AUTOMATIC
CLEANING
SYSTEM

saves on staff time

HOODINI
VENTLESS
HOOD 
SAVES ENERGY

over a traditional hood system

Induction Oven Ranges

Delivering across the range



Reduced energy usage



Labour saving



OPUS 800



DELIVER
90%
EFFICIENCY

compared to 55% with a solid electric hot plate and 50% with a gas hob

AUTOMATIC
PAN
DETECTION

function cuts power when no pan is present, preventing harm to users, while **saving energy**

MULTIPLE INTERNAL
COOLING
FANS

and overheat protection for **long service life**

VENTILATION AND AIR CONDITIONING
COSTS

can also be reduced, as the heat is generated in the pan instead of the hob surface, **focusing energy** where it's needed and **not wasting** it into the kitchen.

EASY TO
CLEAN
& **HYGIENIC**

with high impact resistant ceramic glass surfaces. It's tough too!

Induction Hobs

2x 3.5kW ZONES

OE8020



NEW

4x 3.5kW ZONES

NEW

OE8021



Suites with Opus 800 Series

2x 5.3kW ZONES

OE8018



4x 5.3kW ZONES

OE8019



OPUS 800

2x 1.85kW ZONES
BOOSTED to 3kW



PHEH01



DELIVER
90%
EFFICIENCY

compared to 55% with a solid electric hot plate and 50% with a gas hob

AUTOMATIC
PAN
DETECTION

function cuts power when no pan is present, preventing harm to users, while **saving energy**

MULTIPLE INTERNAL
COOLING
FANS

and overheat protection for long service life

Delivering across the range



Reduced energy usage



Labour saving



1x 3kW ZONE

SLI3



1x 2.4kW ZONE

SLI3W



Suites with Silverlink 600 Series



1x 2kW, 1x 1kW ZONES

SLI21



2x 2kW, 2x 1kW ZONES

SLI42



SILVERLINK 600



1x 2.4kW ZONES

IH3



1x 2kW, 1x 1kW ZONES

IH21



2x 2kW, 2x 1kW ZONES

IH42



Lincat Specialist

VENTILATION AND AIR CONDITIONING COSTS

can also be reduced, as the heat is generated in the pan instead of the hob surface, **focusing energy** where it's needed and **not wasting** it into the kitchen.

EASY TO CLEAN & HYGIENIC

with high impact resistant ceramic glass surfaces. It's tough too!

Electric Fryers

Delivering across the range

Reduced energy usage

Labour saving

Reduced oil usage

Reduced food waste



Thermal insulation reduces heat loss to less than 0.4 °C/minute



frifri Touch

NOW with

 FRYER CHIEF

OIL ASSISTANT FOR EXTENDED OIL LIFE

REDUCE FOOD WASTE
 Adaptive cooking, never undercook food again

TWO STAGE FILTRATION EXTENDS OIL LIFE BY UP TO 75%

ELECTRONIC TEMPERATURE CONTROL FOR EXTENDED OIL LIFE & ENERGY SAVING

UNIQUE ELEMENTS FOR EXTENDED OIL & ELEMENT LIFE

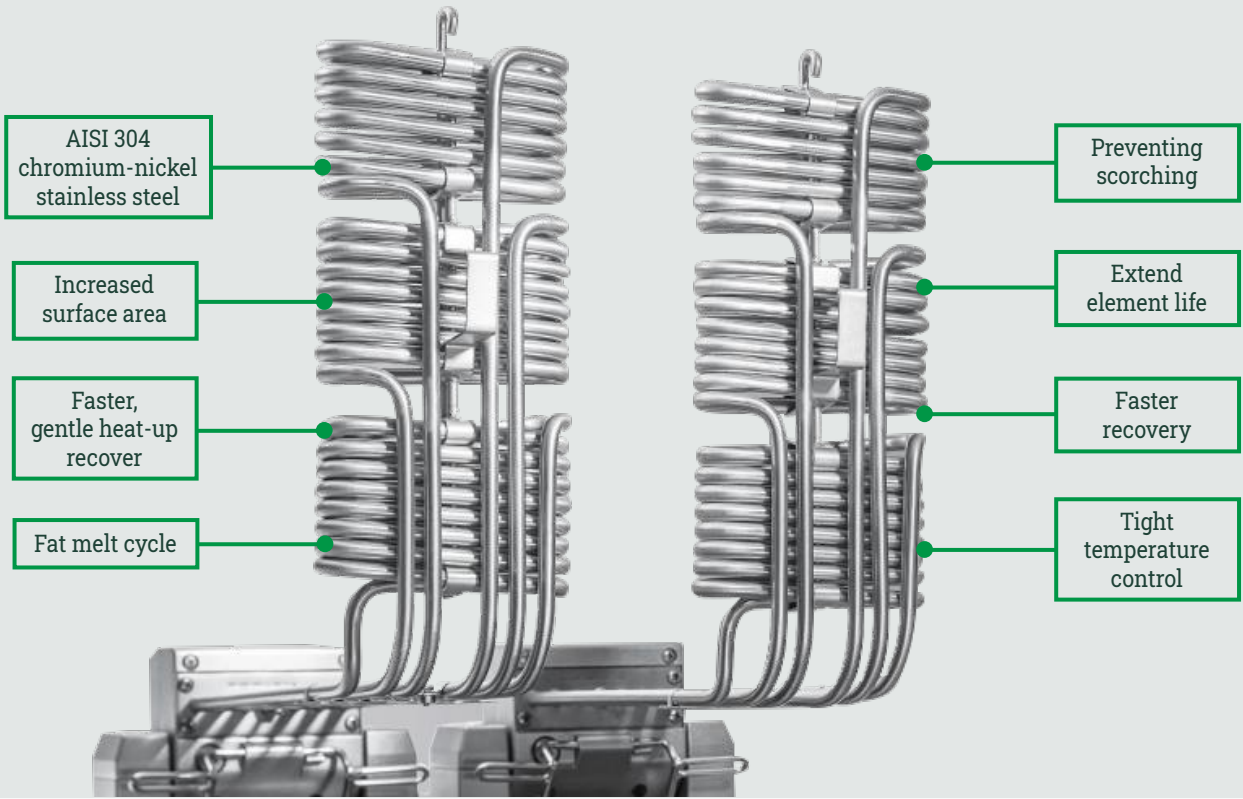

Data Management

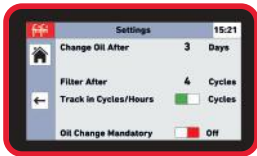

Oil Management

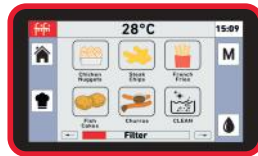

Oil Assistant



Energy Management

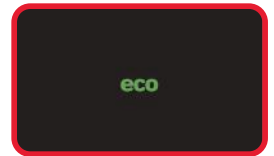

eco mode

xFRI® PUMPED FILTRATION
FOR EASE & SAFETY

ECO MODE FOR **ENERGY SAVINGS,**
 EXTENDED OIL & ELEMENT LIFE

OIL MANAGEMENT FOR **EXTENDED OIL LIFE**

REDUCE FOOD WASTE
LIFTFRI® AUTOMATIC BASKET LIFT OPTION
 never undercook food again

COOK JUST **WHAT YOU NEED - TWIN & TRIPLE TANKS**

MAKE INFORMED **BUSINESS DECISIONS** WITH **DATA MANAGEMENT**

Gas Fryer

Delivering across the range



Reduced energy usage



Labour saving



Reduced oil usage



OPUS 800

TWO STAGE FILTRATION EXTENDS OIL LIFE BY UP TO **75%**

DELIVER **97%** ENERGY EFFICIENCY
Independent BSI test

SAFER. REDUCE RISK OF **HOT OIL** SPILLAGE OR ACCIDENTS
with pumped filtration as standard

RESIDUAL **HEAT** RECOVERY SYSTEM
maximising energy efficiency

MAXIMISE **OIL LIFE.** FILTER OIL **DURING** OR AFTER **SERVICE**
Be ready to go in 5 mins

EASY TO **CLEAN** EASY ACCESS **TANKS**

SAFER. OIL DRAINAGE THROUGH THE BODY OF THE **FRYER**

Electric Eco Salamander

Delivering

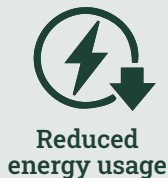

Reduced energy usage

SGE1



SILVERLINK 600

 ON DEMAND
COOKING
DELIVERING
SAVINGS

without operational compromise

 **50%**
ENERGY
SAVING

compared to standard
Silverlink GR3

 **50%**
POWER
MODE

keeps the cavity warm
for fast recovery

CUSTOMISABLE
FULL POWER AND
 **50%**
TIMERS

to tailor the unit to your
menu and desired level of
energy saving

**AUTO OFF
TIMER**
TO ACHIEVE

maximum energy
savings during
quieter periods

HIGH TEMPERATURE
GLASS
COVERED
ELEMENTS, 

removable roasting rack
and crumb tray, make it
effortless to keep clean

Cook & Hold Salamander

Delivering



Reduced energy usage



Speedier cooking



Reduced food waste



OPUS 800

FAST
HEAT UP.
READY TO
COOK IN
8 SECONDS

ENERGY SAVING
PLATE
DETECTION

REDUCE **FOOD WASTE.**
Hold function keeps food warm but does not continue to cook

3
COOK
ZONES

Only turn on the area you need

REDUCE **HEAT LOSS**

Self-balancing height adjustable grill hood

Adjustable Salamander

Delivering



Reduced energy usage



Speedier cooking

GNI/1 compatible



PHEAS01

15 minute timer



FAST
HEAT UP.
READY TO
COOK IN
8 SECONDS

REDUCE
HEAT LOSS

Self-balancing
height adjustable
grill hood

3
COOK
ZONES

Only turn on the
area you need

Clam Griddles

Delivering across the range



Reduced energy usage



Labour saving



Speedier cooking



Reduced food waste



Increased food yield



OE8211

400mm wide and 800mm wide models

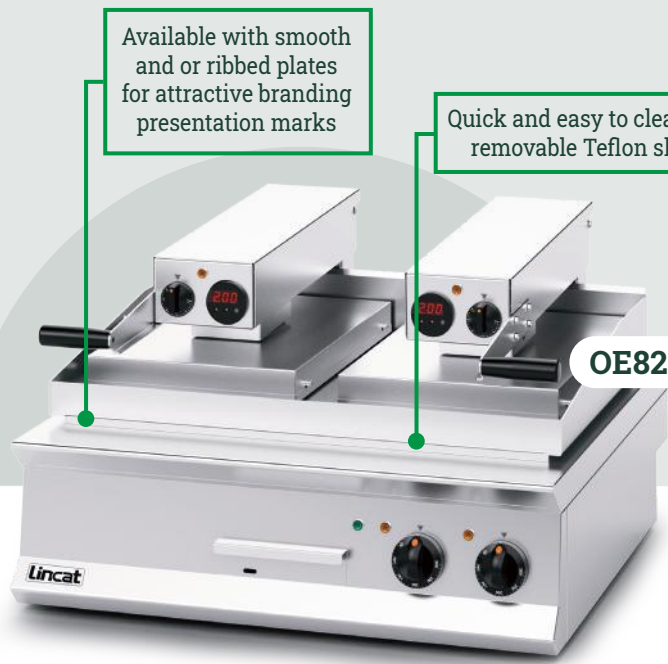

OE8210

Available with smooth and or ribbed plates for attractive branding presentation marks

Quick and easy to clean with removable Teflon sheets

OPUS 800

COOKS UP TO x3 QUICKER

Than a standard griddle

2 COOK ZONES

Only turn on the area you need (OE8210)

REDUCE FOOD WASTE.



Digital timer on each plate for repeatable results

INCREASE YIELD LESS SHRINKAGE

High Efficiency Gas Chargrills

Delivering across
the range



Reduced
energy usage



Labour
saving



OPUS 800

FAST
HEAT UP.
POWERFUL
RED CERAMIC
PLAQUE BURNERS

3/5/7
COOK
ZONES

Only turn on the
area you need

EASIER TO
CLEAN.
SELF-CLEANING
CAST IRON
BRANDING GRIDS

SAVE UP TO
£900
IN GAS
PER YEAR 
(900mm)

High Efficiency Electric Chargrills

Delivering across the range



Reduced energy usage



Labour saving

OE8415



OE8416



OE8417



OPUS

IGNITE



USES 41% LESS ENERGY

compared to a Direct Cook Chargrill

3x FASTER CLEANING

with an enameled base plate, three-piece splashback and fat vapourising technology

INDEPENDENTLY CONTROLLED COOK ZONES

to meet varying service demands and saving energy

23% MORE USABLE COOK SPACE

compared to a Direct Cook Chargrill

High Speed Ovens

Delivering across the range



Reduced energy usage



Labour saving



Speedier cooking



Reduced food waste

Re-circulates the hot cooking air through a heater and catalytic convertor before its blown back into the cooking chamber

AIR0/B



Direct cook on base, no need to warm a baking tray

AIR0/S



REDUCE **FOOD WASTE.**

Cook on demand

VENTLESS COOKING USES LESS

energy over traditional hood systems

FAST COOKING **SAVE ENERGY** AND INCREASE **STAFF EFFICIENCY**

98% RECYCLABLE COMPONENTS

High Speed Ovens

Delivering across the range



Reduced energy usage



Labour saving



Speedier cooking



Reduced food waste

TCIBOPLUS/B



Direct cook on base, no need to warm a baking tray

CIBO+

TURBOCHEF

25% FASTER HEAT UP

12x FASTER COOKING

VENTLESS COOKING USES LESS **energy over traditional hood systems**

ECO MODE USES LESS THAN 1kW PER HOUR

FASTER CLEANING. RAPID COOLDOWN+

REDUCE FOOD WASTE. **Cook on demand**

98% RECYCLABLE COMPONENTS

Eco Toaster

Delivering



Reduced energy usage



Labour saving



CT2

Lincat Specialist

The same output as our popular CT1, but with up to 50% less energy usage!

High volume toasting during busy breakfast periods

Versatile control of browning

 **ON DEMAND COOKING DELIVERING SAVINGS**

without operational compromise

Typical breakfast serving period - up to

 **50% ENERGY SAVING**

compared to CT1

 **HIGH EFFICIENCY I.R ELEMENTS**

for reduced power usage

 **43% POWER MODE**

keeps the cavity warm for fast recovery

Hot Holding Bins

Delivering across the range



Reduced energy usage



Labour saving



Reduced food waste



Use with 2 x 1/1GN, 4 x 2/4GN or a combination of these

HHB12100



Use with 3 x 1/1GN, 6 x 2/4GN or a combination of these

HHB13100



Intuitive digital controls

PANTHER

Timer Versions

Expanding on the success of our popular hot hold bins, our newest models feature simple operation shelf timers for precise food holding time tracking for up to 2 hours for each individual bin.



HHB13100T



HHB12100T



REDUCE **FOOD WASTE**



Hold for up to 1 hour in perfect serving condition

2/3 ZONES

Only turn on the area you need

SPEED UP SERVICE - EASY ACCESS DESIGN

MAXIMISE EFFICIENCY PREPARE AHEAD OF **BUSY PERIODS**

Hot Air Merchandisers

Delivering across the range



Reduced energy usage



Labour saving



Reduced food waste



HAD40

Compact 400mm and 500mm wide design

HAD50

Ideal for all sorts of pre-cooked foods including pies, pizzas and sausage rolls



SEAL

GRAB & GO!

REDUCE **FOOD WASTE.**

Hold for up to 4 hours in perfect serving condition

MAXIMISE **EFFICIENCY**
PREPARE AHEAD OF
BUSY PERIODS

MAXIMISE **ENERGY EFFICIENCY**

Hot Air curtain minimises heat loss

Water Boiler

Delivering



Reduced energy usage



Labour saving

Intuitive digital controls

EB3FX



 MAXIMISE
STAFF
EFFICIENCY

No more waiting for the kettle to boil

ECO 
MODE

Reduce the volume of boiling water **by 50%** for quieter periods

 ENERGY
SAVING
7 DAY TIMER

Switch off overnight or at weekends

ECONOMICAL
INTELLIGENT
PREDICTIVE
ECO 
SETTING

Learns usage patterns and switches between eco and standard mode to deliver required output

Food Waste Management

Delivering across the range



Reduced energy usage



Labour saving



Transport saving

Onward processes include in-vessel composting, anaerobic digestion or production of compressed pellets for biofuels

High capture rates improve the quality of the grey water going to drain

WasteStation

WasteStation Compact



WASTE STATION

80%
REDUCTION
IN WASTE
VOLUME

60%
REDUCTION
IN WASTE
MASS

LABOUR
SAVING.
REDUCE STAFF
TIME
MANAGING WASTE

ENERGY
SAVING
SHORT PROCESSING
TIME

REDUCE
WASTE.
SENT
TO LANDFILL

EASY
CLEAN.
SELF
CLEANING CYCLE

Ensures system is free from food

Dry Waste Compactors

Delivering across the range



Reduced energy usage



Labour saving



Transport saving

Compresses all dry waste, including cardboard, tins, plastic and paper

F56/500



F56/700



Compact easy to move unit can be conveniently located where waste is produced



80%
REDUCTION
IN WASTE
VOLUME

REDUCE
WASTE.
SENT
TO LANDFILL



LABOUR
SAVING.
REDUCE STAFF
TIME
MANAGING WASTE